

# AGENDA

## SPECIAL MEETING

# OKLAHOMA TURNPIKE AUTHORITY

**SEPTEMBER 23, 2024**

### **Location:**

**ODOT Commission Room**

**200 NE 21<sup>st</sup> Street**

**Oklahoma City, OK 73105**

**GOVERNOR J. KEVIN STITT**

**MEMBER EX-OFFICIO**

### Authority Members

**Mr. John D. Jones, Chairman**

**Mr. Will L. Berry, Vice-Chairman**

**Mr. Todd A. Cone, Secretary/Treasurer**

**Mr. Gene Love, Member**

**Mr. John A. Titsworth, Member**

**Ms. Dana Weber, Member**

**Mr. Joe Echelle, Executive Director**



**OKLAHOMA**  
Turnpike Authority

# SPECIAL MEETING

## OKLAHOMA TURNPIKE AUTHORITY

ODOT Commission Room  
200 NE 21<sup>st</sup> Street  
Oklahoma City, OK 73105

SEPTEMBER 23, 2024

### AGENDA

10:00 AM

This Special Meeting will be an in-person open meeting held at the ODOT Commission Room. No Authority Member will join or participate in this meeting via videoconference. For public access to the agenda, which includes the agenda items and exhibits / attachments thereto, and related materials provided to the Board for the meeting, please go to [www.pikepass.com](http://www.pikepass.com).

The following options are available for the public to access this Meeting:

- To watch: Public access meeting link to a livestream video broadcast:  
<https://video.ibm.com/channel/jsW2fC3uurE>
- Attend in-person (ODOT Commission Room)

I. CALL TO ORDER

II. ROLL CALL

III. RECOGNITIONS AND OTHER AWARDS

IV. APPROVAL OF MINUTES for the Regular Meeting of August 6, 2024

V. ITEMS OF BUSINESS

FINANCE ITEM(S)

ITEM 1218 Consider, take action and vote for the approval or disapproval of the Payment Register for the month of July 2024. – Bridget Patterson

ENGINEERING AND CONSTRUCTION ITEM(S)

ITEM 1219 Consider, take action and vote for the approval or disapproval of the following Change Order(s)/Supplemental Agreement(s) – Jeff Garder

<u>Contract No.</u>	<u>Contractor</u>	<u>Amount</u>	<u>Time</u>
1. C-MC-30, CO #2	Frontier Bridge, Inc.	\$0.00	75 Days
2. GCT-2500, CO #33	Gilcrease Developer's, LLC	\$4,260,806.58	72 Days
3. T-MC-107D2, CO #10	Sherwood Construction Co., Inc.	\$276,318.86	0 Days
4. T-MC-128C, CO #2	Sherwood Construction Co., Inc.	\$160,113.45	0 Days

**ITEM 1220** Consider, take action and vote for the approval or disapproval of the following Construction Contract Award(s) including a 15-Day Extension for award. – Darian Butler

<u>Contract No.</u>	<u>Low Bidder</u>	<u>Amount</u>	<u>Fund</u>
* 1. T-MC-128B Pavement Widening and Service Plaza Modernization Lincoln County Turner Turnpike	Becco Contractors, Inc.	\$38,497,000.00	CONST

*\* The Oklahoma public Competitive Bidding Act requires an award of contract within thirty (30) days of bid opening unless the governing board of the awarding agency provides for a reasonable extension of time not to exceed fifteen (15) days (61 O.S. §111). Bids on T-MC-128B were opened on August 15, 2024. Staff requests Board approval of a 15-day extension to the period of time for action to be taken on these contracts for good cause.*

**ITEM 1221** Consider, take action and vote for the approval or disapproval of the following On-Demand Design Contract Modification(s) for ACCESS Bond Program. – Darian Butler

<u>Contract No.</u>	<u>Consultant</u>	<u>Amount</u>	<u>Fund</u>
1. COW-12 Modification No. 3 Project No. JKT-30002, SET-27004, SET-27005, and T-26002	Cowan	NTE \$982,250.00	CONST

**ITEM 1222** Consider, take action and vote for the approval or disapproval to declare approximately 58.63 acres in Canadian and Pittsburg Counties on the John Kilpatrick and Indian Nation Turnpikes as surplus and to authorize the Director to obtain a survey, appraisal and sell, lease or otherwise dispose of the property, including use in a land swap. – Rhonda Powell

**VI. REPORTS: \* INFORMATION ONLY – NO BUSINESS WILL BE TRANSACTED \***

1. Highway Patrol Report – Major Garrett Vowell
2. Consulting Engineer Report – Jimmy Sparks
3. Trustee Report – Rachel Singleton
4. Operating Results and Financial Condition – Wendy Smith
5. Director Report – Joe Echelle

**VII. MOTION FOR ADJOURNMENT to the next meeting scheduled for Tuesday, October 8, 2024, at 10:00 am.**

Office of the Director

OKLAHOMA TURNPIKE AUTHORITY

AGENDA ITEM

SUBJECT: Comptroller Division  
Payment Register

DATE: September 23, 2024

Submitted for the consideration and approval of the Authority are the Payment Register for the period of July 1, 2024 to and including July 31, 2024.

Staff has reviewed the above Item(s) and recommends approval.

AUTHORITY MEETING: **September 23, 2024**

ITEM NO. **1218**

The above Item is:

Comments:

Office of the Director

OKLAHOMA TURNPIKE AUTHORITY

AGENDA ITEM

SUBJECT: Construction Division  
Change Order(s)  
Supplemental Agreement(s)

DATE: September 23, 2024

Submitted for the consideration of the Authority is a request that the following Change Orders and Supplemental Agreements be approved/disapproved. A summary of the item(s) is as follows:

	<u>Project No.</u>	<u>Contractor</u>	<u>Amount</u>	<u>Time</u>
1.	C-MC-30, CO #2	Frontier Bridge, Inc.	\$0.00	75 Days
2.	GCT-2500, CO #33	Gilcrease Developer's, LLC	\$4,260,806.58	72 Days
3.	T-MC-107D2, CO #10	Sherwood Construction Co., Inc.	\$276,318.86	0 Days
4.	T-MC-128C, CO #2	Sherwood Construction Co., Inc.	\$160,113.45	0 Days

The Construction Staff have reviewed the above item(s) and recommend approval.

AUTHORITY MEETING: **September 23, 2024**

ITEM NO. **1219**

The Above Items Is:

Comments:



CHANGE ORDERS WITH CUMULATIVE TOTAL GREATER THAN \$150,000

AUTHORITY MEETING DATE : 09/23/2024

PROJECT NO: C-MC-30 CONTRACTOR: FRONTIER BRIDGE, INC.
TURNPIKE: CIMARRON DESIGNER: CP&Y, INC.

CONTRACT DESCRIPTION: BRIDGE NO. 22.50 REHABILITATION AND CABLE BARRIER

ORIGINAL CONTRACT AMOUNT: \$9,718,267.05 ORIGINAL CONTRACT DAYS: 240 ORIGINAL B TIME: 230
CHANGE ORDER NUMBER: 0002 PREVIOUS APPROVED TOTALS: \$349,957.54 THIS CHANGE ORDER AMOUNT: \$0.00

CHANGE ORDER DESCRIPTION: This Change Order increases the "B" Bid Time by seventy-five (75) days and the Contract Time by sixty-six (66) days to compensate the contractor due to unexpected delays and changes to the scope of work.

Time Adjustments

Table with 5 columns: Time Description, Original, Current, Adjustment, New Total. Rows include Original Contract Days and Original B Time.

Table with 8 columns: CO Amount, %, SA Amount, %, Total Amount, %. Rows include CUMULATIVE PROPOSED, CUMULATIVE TO DATE, PROPOSED CHANGE AMOUNT, ORIGINAL CONTRACT AMOUNT, and PROPOSED CONTRACT AMOUNT.

Table with 4 columns: ORIGINAL BID RESULTS, PART "A" BID, PART "B" BID, TOTAL BID. Rows include ENGINEERS ESTIMATE, Frontier Bridge, Inc., MANHATTAN ROAD & BRIDGE CO., and BRIDGECO CONTRACTORS, INC.



# CHANGE ORDERS WITH CUMULATIVE TOTAL GREATER THAN \$150,000

AUTHORITY MEETING DATE : 9/23/2024

<b>PROJECT NO:</b> GCT-2500	<b>CONTRACTOR:</b> GILCREASE DEVELOPERS, LLC
<b>TURNPIKE:</b> GILCREASE EXPRESSWAY	<b>DESIGNER:</b> GARVER

**CONTRACT DESCRIPTION:** GRADE, DRAIN, BRIDGE, & SURFACE, TULSA COUNTY

<b>ORIGINAL CONTRACT AMOUNT:</b>	\$259,312,641.00	<b>ORIGINAL CONTRACT DAYS:</b> 865	<b>ORIGINAL B TIME:</b> 0
<b>CHANGE ORDER NUMBER:</b> 0033		<b>PREVIOUS APPROVED TOTALS:</b> \$7,221,260.91	<b>THIS CHANGE ORDER AMOUNT:</b> \$4,260,806.58

**CHANGE ORDER DESCRIPTION:** This Supplemental Agreement adds two (2) new items to the contract to compensate the contractor for additional work. The item 'Unrecoverable Overhead / Direct Cost -Third Party Utility Delays' was added to address overhead and equipment standby costs incurred by the contractor because of third-party utility relocation out-by-dates exceeding the dates contained in the contract documents and impacting the critical path of construction demonstrated in the CPM schedule. There was a total of twenty-nine (29) individual third-party utility relocations which did not meet the contractual dates resulting in seventy-two (72) days of delay and extended overhead costs to the project which could not be overcome by alternate phasing. The item 'Unrecoverable Overhead - Supplemental Agreement Items' is being added to compensate the contractor for extended overhead and direct cost associated with the execution of previously approved supplemental agreements and items added to the punch list after substantial completion was granted. These additional punch list items resulted from the City of Tulsa's final review of 41st St and 51st intersections. These items contain all materials, labor, and equipment necessary to perform this work.

### Time Adjustments

Time Description	Original	Current	Adjustment	New Total
Original Contract Days	865	943	72	1015

### New Items

Item Description	Unit	Unit Price	Quantity	Change Order	Supplemental	Total
UNRECOVERABLE OVERHEAD - SUPPLEMENTAL AGREEMENT ITEMS	LSUM	\$732,020.03	1	\$0.00	\$732,020.03	\$732,020.03
UNRECOVERABLE OVERHEAD / DIRECT COST - THIRD PARTY UTILITY DELAYS	LSUM	\$3,528,786.55	1	\$0.00	\$3,528,786.55	\$3,528,786.55

	Co Amount	%	SA Amount	%	Total Amount	%
<b>CUMULATIVE PROPOSED:</b>	\$0.00	0.00%	\$4,260,806.58	1.64%	\$4,260,806.58	1.64%
<b>CUMULATIVE TO DATE:</b>	\$0.00	0.00%	\$7,221,260.91	2.78%	\$7,221,260.91	2.78%
<b>PROPOSED CHANGE AMOUNT:</b>	\$0.00	0.00%	\$11,482,067.49	4.43%	\$11,482,067.49	4.43%
			<b>ORIGINAL CONTRACT AMOUNT:</b>		\$259,312,641.00	
			<b>PROPOSED CONTRACT AMOUNT:</b>		\$270,794,708.49	



AUTHORITY MEETING DATE : 09/23/2024

**PROJECT NO:** T-MC-107D2  
**TURNPIKE:** TURNER

**CONTRACTOR:** SHERWOOD CONSTRUCTION CO., INC.  
**DESIGNER:** EST, Inc.

**CONTRACT DESCRIPTION:** INTERCHANGE MODIFICATION, PAVEMENT WIDENING, AND BRIDGE

**ORIGINAL CONTRACT AMOUNT:** \$35,840,833.63      **ORIGINAL CONTRACT DAYS:** 490      **ORIGINAL B TIME:** 430  
**CHANGE ORDER NUMBER:** 0010      **PREVIOUS APPROVED TOTALS:** -\$1,527,436.65      **THIS CHANGE ORDER AMOUNT:** \$276,318.86

**CHANGE ORDER DESCRIPTION:** This change order establishes the final quantity for items on the original contract and those items added by supplemental agreement that deviated from the original quantity. Deductions or other adjustments associated with this contract will be identified on the final estimate. This change order also provides additional funding for asphalt binder adjustments. In accordance with specification 411.06b, an asphalt binder adjustment of \$276,318.86 is being funded to the contract to compensate for rising binder cost during the course of construction. This project laid approximately 29,000 tons from April 2022 to September 2023.

**New Items**

Item Description	Unit	Unit Price	Quantity	Change Order Amount	Supplemental Amount	Total Amount			
ASPHALT BINDER PRICE ADJUSTMENT	LS	\$276,318.86	1	\$276,318.86	\$0.00	\$276,318.86			
				<b>CO Amount</b>	<b>%</b>	<b>SA Amount</b>	<b>%</b>	<b>Total Amount</b>	<b>%</b>
				<b>CUMULATIVE PROPOSED:</b>				\$276,318.86	0.77%
				<b>CUMULATIVE TO DATE:</b>				-\$1,527,436.65	-4.26%
				<b>PROPOSED CHANGE AMOUNT:</b>				-\$1,251,117.79	-3.49%
				<b>ORIGINAL CONTRACT AMOUNT:</b>				\$35,840,833.63	
				<b>PROPOSED CONTRACT AMOUNT:</b>				\$34,589,715.84	

**ORIGINAL BID RESULTS**

	PART "A" BID	PART "B" BID	TOTAL BID
ENGINEERS ESTIMATE	\$34,372,960.22	\$9,600,000.00	\$43,972,960.22
SHERWOOD CONSTRUCTION CO., INC.	\$35,840,833.63	\$8,600,000.00	\$44,440,833.63
Grade Line Construction, LLC	\$56,103,071.33	\$9,600,000.00	\$65,703,071.33





# CHANGE ORDERS WITH CUMULATIVE TOTAL GREATER THAN \$150,000

AUTHORITY MEETING DATE : 09/23/2024

**PROJECT NO:** T-MC-128C  
**TURNPIKE:** TURNER

**CONTRACTOR:** SHERWOOD CONSTRUCTION CO., INC.  
**DESIGNER:** OLSSON ASSOCIATES

**CONTRACT DESCRIPTION:** FRONTAGE ROAD, COUNTY ROAD, RETAINING WALL, AND BRIDGE 43.4

<b>ORIGINAL CONTRACT AMOUNT:</b>	\$8,317,179.96	<b>ORIGINAL CONTRACT DAYS:</b>	360	<b>ORIGINAL B TIME:</b>	350
<b>CHANGE ORDER NUMBER:</b>	0002	<b>PREVIOUS APPROVED TOTALS:</b>	\$330,477.22	<b>THIS CHANGE ORDER AMOUNT:</b>	\$160,113.45

**CHANGE ORDER DESCRIPTION:** This Change Order overruns three (3) existing items to compensate the contractor for additional work. Solid Slab Sodding is required to provide proper permanent erosion control on all disturbed areas to attain the required NOT for the ODEQ permit in the contract. Traffic Surveillance (OHP) hours are being added due to the additional OHP utilized during the full closures of the Turner Turnpike along the detour route. The closures were needed for demolishing the existing bridge structure and hanging new bridge beams for the Old Stroud Rd bridge. These items contain all labor, materials, and equipment necessary to perform this work.

### Existing Items

Item Description	Unit	Unit Price	Quantity	Change Order Amount	Supplemental Amount	Total Amount
(SP) TRAFFIC SURVEILLANCE, OHP (NON-BID)	HOUR	\$77.00	526	\$40,502.00	\$0.00	\$40,502.00
SOLID SLAB SODDING	SY	\$2.45	16,500	\$40,425.00	\$0.00	\$40,425.00
SOLID SLAB SODDING	SY	\$2.45	32,321	\$79,186.45	\$0.00	\$79,186.45

	CO Amount	%	SA Amount	%	Total Amount	%
<b>CUMULATIVE PROPOSED:</b>	\$160,113.45	1.93%	\$0.00	0.00%	\$160,113.45	1.93%
<b>CUMULATIVE TO DATE:</b>	\$330,477.22	3.97%	\$0.00	0.00%	\$330,477.22	3.97%
<b>PROPOSED CHANGE AMOUNT:</b>	\$490,590.67	5.90%	\$0.00	0.00%	\$490,590.67	5.90%

<b>ORIGINAL CONTRACT AMOUNT:</b>	\$8,317,179.96
<b>PROPOSED CONTRACT AMOUNT:</b>	\$8,807,770.63

ORIGINAL BID RESULTS	PART "A" BID	PART "B" BID	TOTAL BID
ENGINEERS ESTIMATE	\$8,801,777.71	\$3,500,000.00	\$12,301,777.71
SHERWOOD CONSTRUCTION CO., INC.	\$8,317,179.96	\$3,500,000.00	\$11,817,179.96
BRIDGECO CONTRACTORS, INC.	\$9,487,407.14	\$3,300,000.00	\$12,787,407.14
Haskell Lemon Group, LLC	\$10,316,182.97	\$3,500,000.00	\$13,816,182.97

Office of the Director

OKLAHOMA TURNPIKE AUTHORITY

AGENDA ITEM

SUBJECT: Engineering Division  
Construction Contract Award(s)

DATE: September 23, 2024

Submitted for the consideration of the Authority is a request that the following Item(s) be approved/disapproved. A summary of the Item(s) is as follows:

	<u>Project No.</u>	<u>Low Bidder</u>	<u>Amount</u>	<u>Fund</u>
*1.	T-MC-128B Pavement Widening and Service Plaza Modernization Lincoln County Turner Turnpike	Becco Contractors, Inc.	\$38,497,000.00	CONST

*\*The Oklahoma public Competitive Bidding Act requires an award of contract within thirty (30) days of bid opening unless the governing board of the awarding agency provides for a reasonable extension of time not to exceed fifteen (15) days (61 O.S. §111). Bids on T-MC-128B were opened on August 15, 2024. Staff requests Board approval of a 15-day extension to the period of time for action to be taken on these contracts for good cause.*

Staff has reviewed the above Item(s) and recommends approval.

AUTHORITY MEETING: **September 23, 2024**

ITEM NO. **1220**

The Above Item Is:

Comments:

OKLAHOMA TURNPIKE AUTHORITY

CONSTRUCTION CONTRACT AWARDS  
SUMMARY

---

- \*1. T-MC-128B  
Pavement Widening  
and Service Plaza Modernization  
Lincoln County  
Turner Turnpike

DESCRIPTION: Pavement widening and Stroud Service Plaza Modernization on Turner Turnpike in Lincoln County, Oklahoma. Project includes 1.5 miles of 6 lane widening, re-alignment of the westbound turnpike lanes, and construction of the new service plaza site.

NUMBER OF BIDDERS: (4)

	<u>Part "A" Bid</u>	<u>Part "B" Bid</u>	<u>Total Bid</u>
Engineer's Estimate: Olsson	\$36,037,158.80	425 days/\$8,500,000.00	\$44,537,158.80
<b>Low Bidder: Becco Contractors</b>	<b>\$38,497,000.00</b>	<b>425 days/\$8,500,000.00</b>	<b>\$46,997,000.00</b>
2 <sup>nd</sup> Lowest: Duit Construction Co.	\$39,793,944.65	425 days/\$8,500,000.00	\$48,293,944.65
3 <sup>rd</sup> Lowest: Koss Construction Co.	\$40,691,380.42	425 days/\$8,500,000.00	\$49,191,380.42

*\*The Oklahoma public Competitive Bidding Act requires an award of contract within thirty (30) days of bid opening unless the governing board of the awarding agency provides for a reasonable extension of time not to exceed fifteen (15) days (61 O.S. §111). Bids on T-MC-128B were opened on August 15, 2024. Staff requests Board approval of a 15-day extension to the period of time for action to be taken on these contracts for good cause.*

Office of the Director

OKLAHOMA TURNPIKE AUTHORITY

AGENDA ITEM

SUBJECT: Engineering Division  
On-Demand Design Contract Modification(s)  
for ACCESS Bond Program

DATE: September 23, 2024

Submitted for the consideration of the Authority is a request that the following Item be approved/  
disapproved. A summary of the Item is as follows:

	<u>Contract No.</u>	<u>Consultant</u>	<u>Amount</u>	<u>Fund</u>
1.	COW-12 Modification No. 3 Project No. JKT-30002, SET-27004, SET-27005, and T-26002	Cowan	NTE \$982,250.00	CONST

This contract modification is to provide compensation for additional engineering services for the respective ACCESS Program projects. This change will increase the consultant's NTE contract amount to include all contract milestones on project JKT-30002. Project milestones include plan stages of 30% completion, 60% completion, 90% completion, 100% PS&E, bidding phase, construction services, and project completion documentation including as-built plans.

Projects included in this contract are as follows:

- JKT-30002 – John Kilpatrick - Widening - North of the Canadian River Bridges North to ½ section South of County Line Road
- SET-27004 – South Extension - South of SH-9 Interchange South to Etowah Road Interchange
- SET-27005 – South Extension - Etowah Road Interchange South to US-77 Interchange
- T-26002 – Turner - Widening - East of Hiwassee Road East to Kickapoo Turnpike

The amount due under this Contract Modification No. 3 shall not exceed \$982,250.00 for engineering services. The revised contract amount NTE is \$8,489,377.00.

Staff has reviewed the above Item(s) and recommends approval.

AUTHORITY MEETING: **September 23, 2024**

ITEM NO. **1221**

The Above Item Is:

Comments:

Office of the Director

OKLAHOMA TURNPIKE AUTHORITY

AGENDA ITEM

SUBJECT: Right of Way, Utilities & Facilities Division  
Declare Surplus Property and  
Authorize the Director to Sell, Lease  
or Otherwise Dispose of the Same

DATE: September 23, 2024

The following parcels, consisting of the approximate acres and at the locations identified below, were previously acquired by the Authority:

**“SEE ATTACHMENT 1”**

A staff review of the property was conducted, and it has been determined that a portion of the described parcels, in the approximate acreage identified, was acquired as uneconomic remnants and is not needed for any construction or maintenance needs of the Turnpike System. Based on that determination, staff recommends that the Authority consider and vote to declare the attached described parcels surplus and authorize the Director to obtain a survey, appraisal, and sell, lease, or otherwise dispose of the property, including use in a land swap to acquire other property needed for the turnpike system.

AUTHORITY MEETING: **September 23, 2024**

ITEM NO. **1222**

The Above Items Is:

Comments:

## ATTACHMENT '1'

<b>NO.</b>	<b>PARCEL</b>	<b>SEC</b>	<b>TWN</b>	<b>RNG</b>	<b>ACRES</b>	<b>COUNTY</b>	<b>TURNPIKE</b>	<b>Public Access</b>
1	JK-115 North	13	13N	5W	5.68	Canadian	JKT	No
2	JK-115 South & JK-117	13	13N	5W	4.38	Canadian	JKT	Yes
3	JK-127 & JK-129	1	12N	5W	24.84	Canadian	JKT	Yes
4	IN-EA 64 Tr 1 (West)	26	8N	13E	10.8	Pittsburg	Indian Nation	No
5	IN-EA-64 Tr 2 (East)	26	8N	13E	11.38	Pittsburg	Indian Nation	No
6	IN-EA-65	26	8N	13E	1.55	Pittsburg	Indian Nation	No

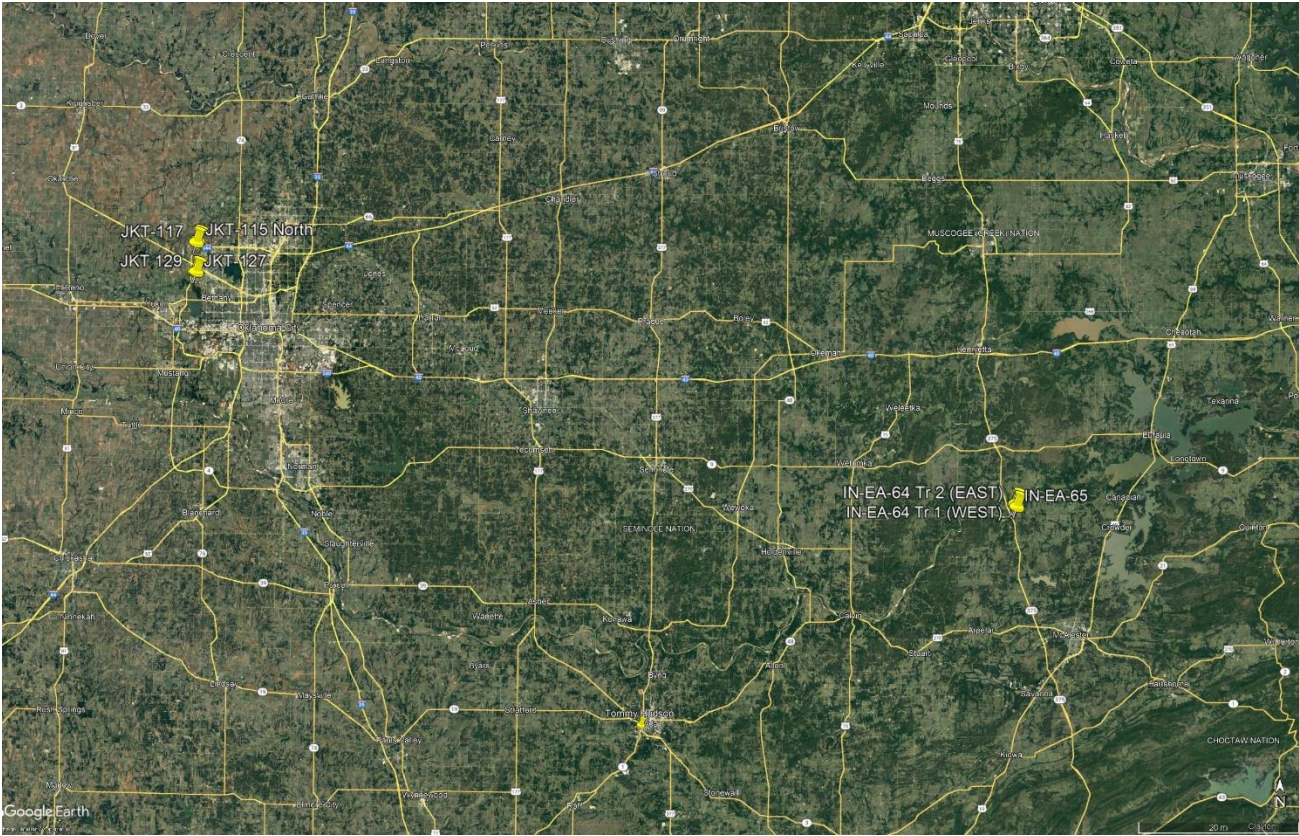

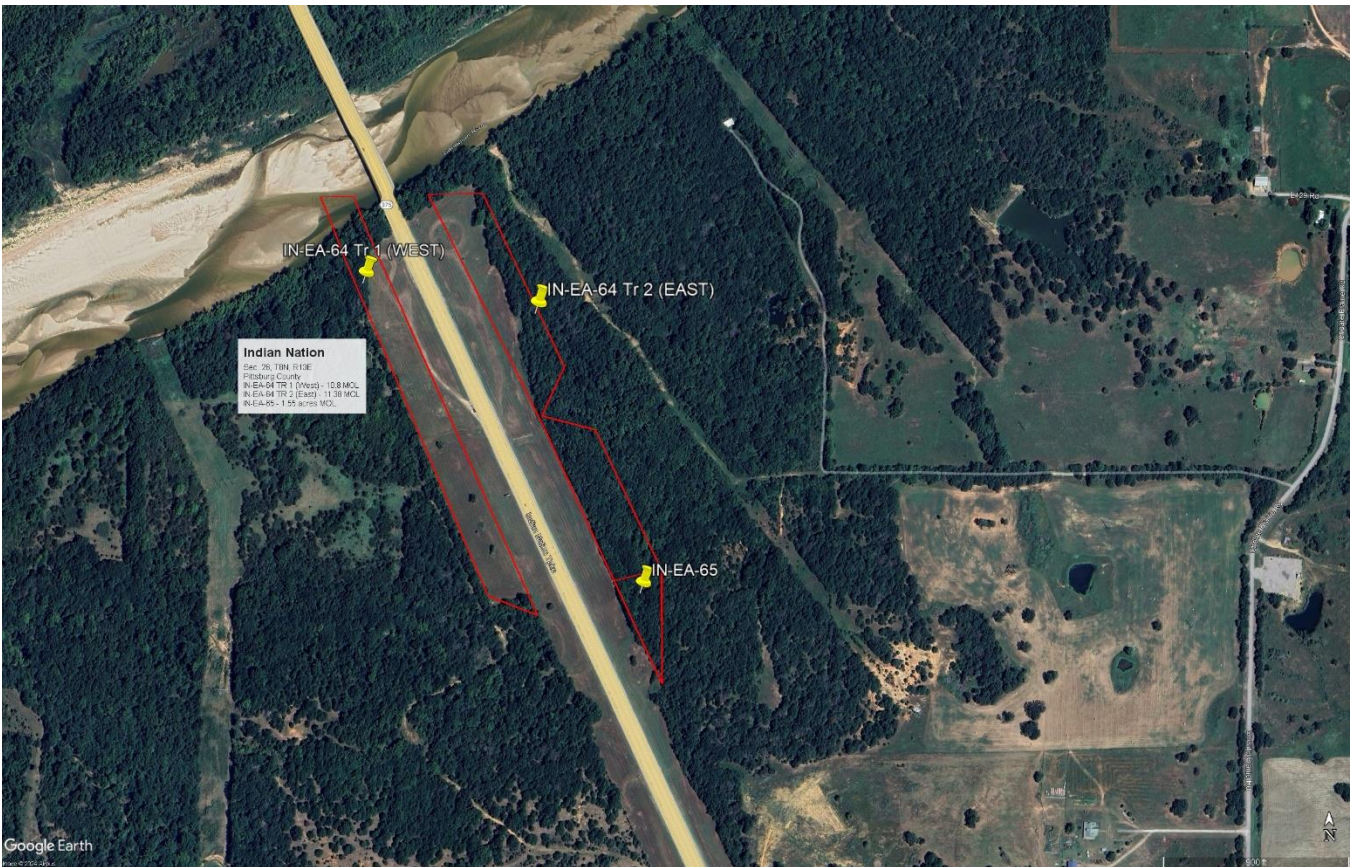
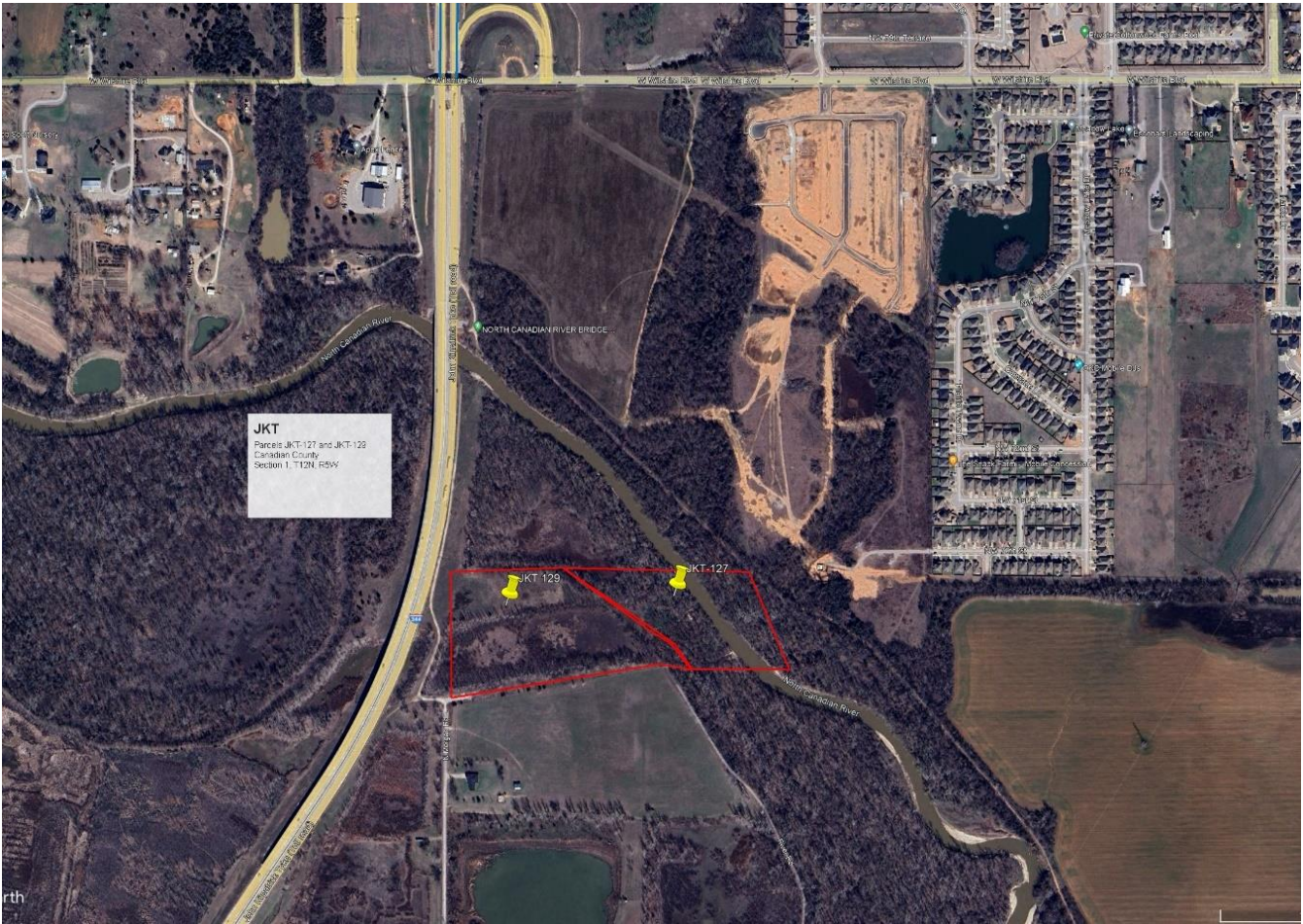





September 23, 2024

Mr. Joe Echelle, P.E. - Executive Director  
Oklahoma Turnpike Authority  
P.O. Box 11357  
Oklahoma City, Oklahoma 73111-4295

**July 31, 2024 Consulting Engineer’s Report**

Dear Mr. Echelle:

The Consulting Engineer’s Report is presented to you in compliance with Section 405, 504, 706, 707, and 708 of the Trust Agreement.

**TRUST REQUIREMENTS**

**INSPECTIONS**

The status of the Consulting Engineer’s Annual Inspections through this report is detailed in the table below.

BRIDGES	CULVERTS	PAVEMENT	ARCHITECTURAL & ELECTRICAL
Chickasaw Cimarron Muskogee Turner	Cherokee Muskogee Will Rogers	Cimarron Chickasaw Creek H.E. Bailey Indian Nation John Kilpatrick Kickapoo Turner Will Rogers	Cherokee Cimarron Chickasaw Creek Gilcrease H.E. Bailey Indian Nation John Kilpatrick Kickapoo Muskogee Turner Will Rogers



The status of the Consulting Engineer's Emergency and/or Special Inspections within this report period is detailed in the table below.

EMERGENCY/SPECIAL INSPECTIONS*
*Emergency Inspection - Turner Turnpike Bridge 78.80 – Vehicle Fire 08/01/24.

\*Detailed reports of emergency and/or special inspections are submitted to OTA Staff and are also included in the Consulting Engineer's Monthly Reports.

### MEETING SERVICES

The meetings attended by the Consulting Engineer are listed in the table below.

PROJECT	MEETING DESCRIPTION
MU-MC-53	99% Plan Review Meeting
SP-73	Preliminary Plan Review Meeting
John Kilpatrick Turnpike	Pavement Inspection
SP-63A	Turner AET Project Status Meeting
SP-63B	Will Rogers AET Project Status Meeting
Project Status Meeting	Discuss Current Projects
Agenda Meeting	Discuss Authority Meeting Agenda
Authority Meeting	Monthly Meeting

If you should have any questions or comments, please contact me at (405)242-6600.

Sincerely,

Jimmy Sparks, P.E.  
Consulting Engineer



## Oklahoma Highway Patrol

### TURNPIKE REPORT

July 2024

For the month of July, troopers made 2,946 violator contacts, assisted 691 motorists, and investigated 121 motor vehicle collisions with two fatalities reported. Troopers worked 928 shifts and averaged 199 miles per shift for a total of 184,331 miles driven.

The Turnpike System reported two fatalities for the month of July.

Will Rogers Turnpike – A pedestrian was killed after walking into oncoming traffic.

Kilpatrick Turnpike – The driver was killed after departing the roadway for an unknown reason.

Drug Interdictions – Cimarron (1) Turner (7) Will Rogers (5)

Special Emphasis troopers worked 12 shifts on the Indian Nation, Cimarron, Turner, H.E. Bailey, and Kilpatrick Turnpikes and contacted 225 violators. These troopers issued 36 citations and 189 warnings for an average of 18.8 contacts per shift.

The aircraft enforcement flew a total of 0 hours.

During July troopers dedicated 254 hours to Toll Enforcement on the Turnpike System. During this time, they issued 49 citations and 365 warnings, confiscated 0 pike passes and issued 0 toll violation letters.

Respectfully,

A handwritten signature in black ink, appearing to read "MAJ Garrett Vowell #11".

MAJ Garrett Vowell #11  
Turnpike Liaison

GV: aft

OKLAHOMA HIGHWAY PATROL  
TURNPIKE REPORT

-ENFORCEMENT ACTION-

TURNPIKE				TRUCK CONTACTS			SELECTIVE PERCENTAGE
	ARRESTS	WARNINGS	TOTAL	ARRESTS	WARNINGS	TOTAL	
Will Rogers	79	434	513	0	133	133	25.93%
Muskogee	37	260	297	4	59	63	21.21%
Indian Nation	16	227	243	0	44	44	18.11%
Cherokee	93	354	447	0	98	98	21.92%
Creek	51	94	145	1	51	52	35.86%
Cimarron	21	70	91	1	38	39	42.86%
Turner	117	355	472	1	112	113	23.94%
H.E. Bailey	146	496	642	4	105	109	16.98%
Chickasaw	3	1	4	0	0	0	0.00%
Kilpatrick	3	89	92	15	11	26	28.26%
TOTALS	566	2,380	2,946	26	651	677	22.98%

-ACCIDENT DATA-

-COLLISION DATA-

TURNPIKE				NUMBER REPORTED INVOLVING TRUCKS	FATALITIES	COLLISIONS
	2024	2023	INC/DEC			
Will Rogers	17	26	-9	9	1	1
Muskogee	11	11	0	1	0	0
Indian Nation	17	13	4	3	0	0
Cherokee	5	2	3	1	0	0
Creek	13	9	4	0	0	0
Cimarron	4	6	-2	2	0	0
Turner	14	47	-33	4	0	0
H.E. Bailey	22	21	1	4	0	0
Chickasaw	0	0	0	0	0	0
Kilpatrick	18	13	5	1	1	1
TOTALS	121	148	-27	25	2	2

-AIRCRAFT TRAFFIC ENFORCEMENT-

TURNPIKE				TRUCK CONTACTS	HIGHEST SPEED
	ARRESTS	WARNINGS	TOTAL		
Will Rogers	0	0	0	0	0
Muskogee	0	0	0	0	0
Indian Nation	0	0	0	0	0
Cherokee	0	0	0	0	0
Creek	0	0	0	0	0
Cimarron	0	0	0	0	0
Turner	0	0	0	0	0
H.E. Bailey	0	0	0	0	0
Chickasaw	0	0	0	0	0
Kilpatrick	0	0	0	0	0
TOTALS	0	0	0	0	

Hours flown: 0.00

Cost at \$124/hour: \$ 0.00

OKLAHOMA HIGHWAY PATROL  
TURNPIKE REPORT

-MILES DRIVEN-

TURNPIKE	MILES DRIVEN	NUMBER DAYS WORKED	AVERAGE MILES/DAY
Will Rogers	33,344	192	174
Muskogee	11,362	66	172
Indian Nation	15,230	71	215
Cherokee	17,679	121	146
Creek	8,727	78	112
Cimarron	12,990	50	260
Turner	43,548	143	305
H.E. Bailey	26,986	106	255
Chickasaw	13	1	13
Kilpatrick	14,452	100	145
<b>TOTALS</b>	<b>184,331</b>	<b>928</b>	<b>199</b>

( YEAR-TO-DATE)

-ACCIDENT COMPARISON-

TURNPIKE	NUMBER REPORTED		
	2024	2023	INC/DEC
Will Rogers	134	128	6
Muskogee	69	65	4
Indian Nation	95	94	1
Cherokee	25	9	16
Creek	64	57	7
Cimarron	38	53	-15
Turner	193	254	-61
H.E. Bailey	125	107	18
Chickasaw	1	1	0
Kilpatrick	127	102	25
<b>TOTALS</b>	<b>871</b>	<b>870</b>	<b>1</b>

-COLLISION DATA-

TURNPIKE	FATALITIES		
	2024	2023	INC/DEC
Will Rogers	1	0	1
Muskogee	0	0	0
Indian Nation	1	1	0
Cherokee	1	0	1
Creek	1	1	0
Cimarron	0	0	0
Turner	3	5	-2
H.E. Bailey	0	0	0
Chickasaw	0	0	0
Kilpatrick	1	0	1
<b>TOTALS</b>	<b>8</b>	<b>7</b>	<b>1</b>

Total arrests issued at honor system gates: 39  
 Total warnings issued at honor system gates: 177  
 Total motorist assists: 691

**OKLAHOMA HIGHWAY PATROL**  
**Year to Date - July 2024**

	FATALITIES	FATALITY COLLISIONS
Ran off roadway	4	4
Hit retaining wall		
Crossed center median		
Parked on the shoulder and hit in the rear		
Turn through barriers		
<u>Speed:</u>		
Excessive speed for conditions		
DUI		
Changing lanes unsafely		
Attempt to elude		
Inattention		
Pedestrian	2	2
Hit in construction zone		
Hit in the rear		
Hit another vehicle head on	1	1
Hit another vehicle in the rear	1	1
Fell asleep		
Hydroplaned		
Hit ice on roadway		
Improper Backing		
Improper U-turn		
Lost control of motorcycle		
Mechanical Defect		
Debris crossing center median		
Passenger side struck		
Obstruction in roadway		
Traveling wrong direction on roadway		
Tire blew out		
Vehicle caught fire		
Unknown/Under Investigation		
<b>TOTALS</b>	<b>8</b>	<b>8</b>

**OKLAHOMA HIGHWAY PATROL  
SIZE & WEIGHTS REPORT  
July 2024**

(Month)

<u>TURNPIKE</u>	<u>Hours</u>	<u>Arrests</u>	<u>Warnings</u>	<u>Inspec.</u>	<u>Out of Service</u>
Will Rogers	60	0	3	31	2
Muskogee	94	0	3	48	10
Indian Nation	9	0	0	7	0
Cherokee	16	0	0	19	2
Creek	46	3	3	28	4
Cimarron	79	1	9	55	8
Turner	65	0	0	23	1
H.E. Bailey	16	0	0	10	1
Chickasaw	0	0	0	0	0
Kilpatrick	149	3	7	73	10
Kickapoo	0	0	0	0	0
<b>TOTALS</b>	<b>534</b>	<b>7</b>	<b>25</b>	<b>294</b>	<b>38</b>

(Year to Date)

<u>TURNPIKE</u>	<u>Hours</u>	<u>Arrests</u>	<u>Warnings</u>	<u>Inspec.</u>	<u>Out of Service</u>
Will Rogers	323	3	18	152	8
Muskogee	531	2	17	245	58
Indian Nation	86	0	0	48	4
Cherokee	245	10	24	240	18
Creek	277	10	19	161	30
Cimarron	328	5	16	280	22
Turner	459	3	17	226	13
H.E. Bailey	78	0	3	51	3
Chickasaw	5	0	0	1	0
Kilpatrick	747	12	59	358	59
Kickapoo	21	0	0	3	0
<b>TOTALS</b>	<b>3100</b>	<b>45</b>	<b>173</b>	<b>1765</b>	<b>215</b>

Three Full-Time Troopers  
Sixteen Additional Troopers with Turnpike Activity

**OKLAHOMA HIGHWAY PATROL  
MOTORS REPORT  
July 2024**

(Month)

<u>Hours</u>	<u>Arrests</u>	<u>Warnings</u>	<u>Total Contacts</u>
966	525	1012	1537

(Year to Date)

<u>Hours</u>	<u>Arrests</u>	<u>Warnings</u>	<u>Total Contacts</u>
4,219	1,883	4,056	5,939

Ten Full-Time Troopers



TURNPIKE FIRE CALLS  
July 2024

Turnpike	Calls	Fire Department	Trucks	Fire Fighters	Hrs to Complete Services	Billed for Services	Amount	Comments
Will Rogers	NONE							
Muskogee	NONE							
Indian Nation	1	Savanna	1	2	15 min			2 SEMI'S MM 64 SB OHP24015212 TRP HANEY#291
Cherokee	1	Chimney Rock	1	2	<1 hr			Grass Fire 7/19//2024
Creek	NONE							
Cimarron	NONE							
Turner	6	Bristow	2	3	1hr			Vehicle Fire - Mile Marker 193
		Stroud	3	5	1 hr			Small grass fire MM183
		Stroud	4	7	1-2 hrs			Vehicle pulled behind RV caught fire
		Chandler	2	5	3-5 hrs			Vehicle Fire MM 162.5
		Wellston	2	3	3-5 hrs			Vehicle Fire MM 162.5
		Chandler	1	2	1 hr			Vehicle Fire MM 174
H. E. Bailey	NONE							
Chickasaw	NONE							
Kilpatrick	NONE							

## MINUTES

### Oklahoma Turnpike Authority REGULAR MEETING

**AUGUST 6, 2024**

MINUTES OF THE REGULAR MEETING OF THE OKLAHOMA TURNPIKE AUTHORITY, HELD AUGUST 6, 2024, AT THE OKLAHOMA DEPARTMENT OF TRANSPORTATION COMMISSION ROOM, 200 NE 21<sup>ST</sup> STREET, OKLAHOMA CITY, OKLAHOMA 73105.

Notice of this Regular Meeting of the Oklahoma Turnpike Authority having been given to the Oklahoma Secretary of State, and public notice and agenda having been posted in prominent public view at the Oklahoma Department of Transportation and on the website of the principal office of the Oklahoma Turnpike Authority, [www.pikepass.com](http://www.pikepass.com), twenty-four (24) hours prior to this meeting, excluding Saturdays, Sundays and legal holidays, all in compliance with the Oklahoma Open Meeting Act.

I. **CALL TO ORDER:** Chairman John Jones called the meeting to order at 10:00 am.

II. **ROLL CALL:** Present: Mr. John D. Jones  
Mr. Will L. Berry  
Mr. Todd A. Cone  
Mr. Gene Love  
Mr. John Titsworth  
Ms. Dana Weber

Absent: None

### III. **RECOGNITIONS AND OTHER AWARDS**

Major Garrett Vowell recognized Trooper Wayne Linzy and Trooper Vince Curtis as the OHP Troopers of the Month for August.

During one of his shifts, Trooper Wayne Linzy pulled up to an abandoned vehicle and noticed that someone had attempted to change a flat and the vehicle had fallen off the jack. Trooper Linzy went ahead and changed the tire, thinking that someone would probably return in a short time to fix the tire. Apparently, the driver of the vehicle and her husband had left vehicle on the side of the road to go and get more tools to fix the problem. They were pleasantly surprised to return and find that the tire had been changed. The owner of the vehicle sent an email expressing her relief and gratitude to Trooper Linzy for helping her. Major Vowell commended Trooper Linzy for his efforts in keeping the public safe on the turnpike system.

Trooper Vince Curtis was recognized for having a direct impact on the safety of the motorists traveling on the Creek Turnpike due to his issuance of 42 speeding citations that were 25 mph over the posted limit or greater. He issued 23 speeding citations for speeds more than 30 mph over the posted speed limit, 19 citations for speeds 25 to 30 mph over the speed limit. The top three citations issued were for vehicles going 127 in a 65 mph zone, 111 in a 65 mph zone, and 108 in a 65 mph zone. He also stopped a violator for speeding 90 mph in an active work zone where the speed was posted at 45 mph. Trooper Curtis maintains a high level of visibility and takes great pride in his work. Major Vowell commended Trooper Curtis for his efforts regarding his speed enforcement.

On behalf of the Board, Chairman Jones thanked Trooper Curtis and Trooper Linzy for their service.

August 6, 2024

Page 2.

**IV. APPROVAL OF MINUTES for the Regular Meeting of July 9, 2024**

Chairman Jones called for approval of the minutes for the Regular Meeting of July 9, 2024. It was moved by Mr. Gene Love and seconded by Ms. Dana Weber that the minutes be approved as presented.

The motion carried by the following vote:

YES: Berry, Cone, Love, Titsworth, Weber, Jones

**V. ITEMS OF BUSINESS**

**FINANCE ITEM(S)**

**ITEM 1209 Consider, take action and vote for the approval or disapproval of a request to authorize the Director to execute a contract with FORVIS Mazars, LLP to provide external audit services to the OTA for the three years ending 2024, 2025 and 2026, with optional renewal for years ending 2027 and 2028. – Micah Gardner**

Ms. Micah Gardner presented this item to the Board as summarized above. She stated staff had reviewed and recommended this item for approval. Mr. Todd Cone asked about the selection process. Ms. Gardner stated that OTA sent out a Request for Proposal (RFP) to audit firms. OTA received three responses. Those RFPs were reviewed by a selection committee at OTA and then reviewed by the Audit Committee before being brought before the Board for approval.

It was moved by Mr. Todd Cone and seconded by Ms. Dana Weber that the Authority approve this item as presented.

The motion carried by the following vote:

YES: Berry, Cone, Love, Titsworth, Weber, Jones

**ITEM 1210 Consider, take action and vote for the approval or disapproval of the toll rates for the Heyburn Interchange on the Turner Turnpike. – Wendy Smith**

Ms. Wendy Smith presented this item to the Board as summarized above. She stated staff had reviewed and recommended this item for approval

It was moved by Mr. Todd Cone and seconded by Ms. Dana Weber that the Authority approve this item as presented.

The motion carried by the following vote:

YES: Berry, Cone, Love, Titsworth, Weber, Jones

**ITEM 1211 Consider, take action and vote for the approval or disapproval of the toll rates for the Flint Road Interchange on the Will Rogers Turnpike. – Wendy Smith**

Ms. Wendy Smith presented this item to the Board as summarized above. She stated staff had reviewed and recommended this item for approval.

It was moved by Mr. Todd Cone and seconded by Ms. Dana Weber that the Authority approve this item as presented.

The motion carried by the following vote:

YES: Berry, Cone, Love, Titsworth, Weber, Jones

**ITEM 1212** Consider, take action and vote for the approval or disapproval of a request to authorize the Director to negotiate and execute an amendment to the 2021 license plate image review agreement with Conduent State and Local Solutions, Inc. (Conduent). This includes the approval of additional compensation for image review services as follows: a scaled cost for image review services ranging from \$0.0610 to \$0.0897 per image set. This amendment is necessary to accommodate the rise in wages and costs associated with AET PlatePay Image Review services provided by Conduent. – Patrice Williams

Ms. Patrice Williams presented this item to the Board as summarized above. She stated staff had reviewed and recommended this item for approval. Mr. Todd Cone asked when the contract was scheduled to expire. Ms. Williams stated in 2026 but per the contract, Conduent could ask for a yearly adjustment. Mr. Gene Love asked how the yearly adjustment was determined. Ms. Williams explained it was based on the number of images reviewed.

It was moved by Mr. Todd Cone and seconded by Ms. Dana Weber that the Authority approve this item as presented.

The motion carried by the following vote:

YES: Berry, Cone, Love, Titsworth, Weber, Jones

**ITEM 1213** Consider, take action and vote for the approval or disapproval of the Payment Register for the month of June 2024. – Bridget Patterson

Ms. Bridget Patterson presented the payment register for the month of June. She stated it had been provided to the Board for their review and staff recommended this item for approval.

It was moved by Mr. Todd Cone and seconded by Ms. Dana Weber that the Authority ratify and approve this item as presented.

The motion carried by the following vote:

YES: Berry, Cone, Love, Titsworth, Weber, Jones

**ENGINEERING AND CONSTRUCTION ITEM(S)**

**ITEM 1214** Consider, take action and vote for the approval or disapproval of the following Change Order(s)/Supplemental Agreement(s) – Jeff Garder

<u>Contract No.</u>	<u>Contractor</u>	<u>Amount</u>	<u>Time</u>
1. IN-MC-66, CO #2	Built Right Construction, LLC	\$48,387.69	0 Days

Mr. Jeff Garder presented this item to the Board as summarized above. He stated staff had reviewed and recommended this item for approval

It was moved by Mr. Will Berry and seconded by Mr. Gene Love that the Authority approve this item as presented.

The motion carried by the following vote:

YES: Berry, Cone, Love, Titsworth, Weber, Jones

August 6, 2024

Page 4.

**ITEM 1215 Consider, take action and vote for the approval or disapproval of the following Construction Contract Award(s) – Darian Butler**

<u>Contract No.</u>	<u>Low Bidder</u>	<u>Amount</u>	<u>Fund</u>
1. C-MC-36 Rehab of Bridge 32.97 at MP 32.97 Cimarron Turnpike	C3 Construction, Inc.	\$2,662,276.76	GEN

Mr. Darian Butler presented this item to the Board as summarized above. Mr. Butler noted this bid was 14.4% below the Engineer’s estimate He stated staff had reviewed and recommended this item for approval. Mr. Gene Love commented he was happy to see more competitive bids.

It was moved by Mr. Will Berry and seconded by Mr. Gene Love that the Authority approve this item as presented.

The motion carried by the following vote:

YES: Berry, Cone, Love, Titsworth, Weber, Jones

**ITEM 1216 Consider, take action and vote for the approval or disapproval of a request to authorize the Director to enter into a project agreement with the City of Broken Arrow to allow for a new connection to East 101<sup>st</sup> Street / East New Orleans Street northbound on-ramp to the Creek Turnpike, near Mile Post 23. The City of Broken Arrow will provide all funding for design, construction, construction management, and tolling equipment. – Darian Butler**

Mr. Darian Butler presented this item to the Board as summarized above. Mr. Butler noted the City of Broken Arrow asked the OTA to partner with them to allow additional access. The City of Broken Arrow would provide the funding. He stated staff had reviewed and recommended this item for approval. Mr. Todd Cone asked if the agreement was a benefit of cashless tolling. Mr. Butler answered yes, it would roll right into an unused cash lane that was closed off. Chairman Jones remarked it was a good use of assets.

It was moved by Mr. Will Berry and seconded by Mr. Gene Love that the Authority approve this item as presented.

The motion carried by the following vote:

YES: Berry, Cone, Love, Titsworth, Weber, Jones

**ITEM 1217 Consider, take action and vote for the approval or disapproval of a request to authorize the Director to execute a new contract with Oklahoma Logos, LLC (“Logos”) effective August 16, 2024. The logo signing program provides motorists with information on gas, food, lodging, camping and tourism attractions. OTA has an existing contract with Logos that expires August 15, 2024. The new contract parallels an identical contract between ODOT and Logos that was recently awarded pursuant to an ODOT competitively bid solicitation process. OTA is utilizing ODOT’s solicitation process for this new contract in accordance with Oklahoma law. OTA’s new contract with Logos will be for the period of August 16, 2024 through August 15, 2029, and provides for three 5-year extensions. The contract will generate an estimated \$240,000 in annual revenue for OTA. – Darian Butler**

**August 6, 2024**

**Page 5.**

Mr. Darian Butler presented this item to the Board as summarized above. Mr. Butler noted this project had generated \$1.5 million in revenue since its inception in 1992. He stated staff had reviewed and recommended this item for approval. Mr. Gene Love asked how the annual revenue compared to previous years. Mr. Butler explained it was based on a percentage the OTA would receive, which was currently 53%.

It was moved by Mr. Will Berry and seconded by Mr. Gene Love that the Authority approve this item as presented.

The motion carried by the following vote:

YES: Berry, Cone, Love, Titsworth Weber, Jones

**VII. REPORTS: \*INFORMATION ONLY – NO BUSINESS WILL BE TRANSACTED\***

**Item #1. Highway Patrol Report**

Major Garrett Vowell presented the OHP report for the month of June. Turnpike Troopers made 3,871 violator contacts and assisted 613 motorists. There were 133 motor vehicle collisions investigated with one fatality reported on the Indian Nation Turnpike. Thirteen drug interdictions were reported on the Will Rogers (10) and Turner Turnpikes (3). Major Vowell stated the information for aircraft, motorcycle enforcement and toll enforcement were provided in the monthly report. Chairman Jones asked if the person involved in the fatality wore a seatbelt. Major Vowell answered no, the person was ejected from the vehicle.

Major Vowell added that on August 16, 2024, there would be a press release for the “Move Over, Slow Down” campaign. It would be advertised across the state on message boards. The OHP would also be focused on drivers not moving over for people on the shoulder not just emergency vehicles.

**Item #2. Consulting Engineer Report**

Mr. Jimmy Sparks presented the Consulting Engineer Report. Concerning the Trust requirements, Olsson was compiling new inspection data in preparation for the annual report due on October 1<sup>st</sup>. In the report, Olsson would update their recommendations for the five-year capital plan. Also of note, in July, Olsson’s Engineers checked 22 overload trucks for travel on the System.

Mr. Sparks continued by following up on a question from the previous month regarding the pavement south of Lawton on the H.E. Bailey Turnpike. That section of pavement had been studied several times and there were discussions of the most cost-effective solutions. Two options would be diamond grinding or reconstruction. While the pavement was faulted, the issue of undulations in the pavement was likely present since the original construction.

Mr. Sparks concluded by sharing that on August 1, 2024, a tractor trailer caught fire underneath Turner Turnpike Bridge 78.8, which is west of the Sapulpa interchange. Olsson engineers were on-site that evening and did a follow up inspection the following day. Olsson is set to discuss repair options with OTA staff and a formal report will be presented to the Board in September 2024.

**Item #3. Trustee Report**

Ms. Rachel Singleton stated as the Bond Trustee to the Authority, all monthly debt service transfers were made for the semi-annual payments due to the Bondholders, as required by the Trust Agreement. To the Trustee’s knowledge, all other requirements set forth in the Trust Agreement had been satisfied.

**August 6, 2024**

**Page 6.**

#### **Item #4. Operating Results and Financial Condition**

Ms. Wendy Smith started out her report by reminding the Board that they had received the Operations Report for June prepared by the Comptroller Division. OTA continues to be in a strong financial position and in compliance with its Trust Indenture as our Trustee reported earlier.

Ms. Smith went on to state that net toll revenues for June 2024 on the Oklahoma Turnpike System reported at \$33.8 million, an increase of 7% as compared to June of 2023. Total transactions were fairly flat as compared to last year with heavy truck traffic continuing to remain strong over that same period. Additionally, year to date toll revenues continue to outpace January through June of 2023 by an impressive 10.3%. Ms. Smith continued by stating that the OTA continues to maintain a conservative approach to spending. Collectively for the year, division managers held revenue fund operating expenses to 21.8% under the 2024 operating and maintenance budget. The OTA continues to steadily achieve and exceed its Trust-required senior and total debt service ratios.

Ms. Smith expressed her appreciation to the Board for the passage of the toll rates for the interchanges slated to open in the next few months. Having access to good schools, hospitals and good roads is good public policy and the Oklahoma Turnpike Authority is happy to continue to provide additional access to its roads to get patrons to their intended destinations. She went on to state as a reminder that having a PIKEPASS in the vehicle provides the specific entry and exit points, thus allowing patrons to be charged for only that segment of road that the patron travelled.

Ms. Smith ended her report by saying that the public will see even more access points being added as the ACCESS program progresses.

#### **Item #5. Director Report**

Director Joe Echelle began his report by thanking the Board for their approval of the new toll rates at the Heyburn and Flint Road interchanges. Those interchanges will provide new access points to the public and will help to increase safety. OTA continues to strive to make improvements to the system to enhance and to make travel easier for everyone.

Director Echelle continued his report by giving an update on the cashless conversion projects. The two remaining turnpikes were set to be converted to cashless tolling by the end of 2024. The Indian Nation Turnpike was set for a partial conversion including Antlers, Eufaula Mainline, and SH 9 ramps at the end of August 2024. McAlester Mainline and US-270 were set to be converted later in the fall. One reason for the partial conversion was due to the number of accidents in toll zones. So rather than waiting, it was better to go ahead and make the conversion to cashless tolling. Demolition of the existing toll plazas were expected to be completed by the end of 2024. Once the cashless conversion was completed, customers no longer needed to stop and pay. They could go online to pay their PlatePay invoices or sign up to become a PIKEPASS account holder.

Director Echelle went on to discuss the recent construction on the Turner Turnpike. SH 66 was expected to close August 21, 2024 in Wellston between eastbound and westbound 1-44/Turner Turnpike ramps. The bridge was outdated, an original construction that needed to be replaced. One reason it was never replaced was due to it being such a challenging area. During construction, local businesses would remain accessible to local traffic. All turnpike ramps were expected to stay open and there would be signed detours for local traffic. OTA has worked closely with the city of Wellston and Lincoln County on this project. Work is expected to be completed in the summer of 2025.

**August 6, 2024**

**Page 7.**

Director Echelle concluded his report by reminding the public about the importance of wearing seatbelts. In Oklahoma, you could increase chances of surviving a major accident by 50% if a seatbelt is worn. With school starting back up, there would be increased traffic on the roads. Director Echelle encouraged the public to continue to talk to their loved ones and friends of the importance of seatbelt usage.

Chairman Jones asked Director Echelle to respond to the recent news of environmental issues concerning OTA. Director Echelle answered that OTA was required to follow all set rules, regulations, and laws that pertain to permitting. OTA seeks multiple permits every year during an expansion project. OTA works with regulators and regulatory agencies and has tried to avoid impacts to any environmental items. There was also a team of consulting Engineers and environmental professionals that worked through these issues. Moving forward with the ACCESS Oklahoma Program, OTA will have third party environmental compliance consultants visiting projects routinely as needed following up on any complaints and always staying in compliance. Ms. Dana Weber commented she appreciated the OTA team for taking these matters seriously and going above and beyond.

**VIII. MOTION FOR ADJOURNMENT:**

Chairman Jones called for adjournment to the next Regular Meeting of September 10, 2024. It was moved by Chairman Jones and seconded by Mr. Todd Cone that the meeting adjourn.

The motion carried by the following vote:

YES: Berry, Cone, Love, Titsworth, Weber Jones

The meeting adjourned at 10:48 am.

**ATTEST:**

---

Todd A. Cone  
Secretary/Treasurer

---

John D. Jones  
Chairman



Report Name ppmtreg1\_sp  
 Start Date 07/01/2024  
 End Date 07/31/2024  
 Style ("N"eal or "T"otal) N  
 Vendor Code \*  
 Threshold 0  
 Fund \*

Oklahoma Turnpike Authority  
 Payment Register by Vendor  
 For 07/01/2024 - 07/31/2024

Run Time  
 8/20/2024 9:42

Run Report

Vendor Name	Fund Desc	Voucher NO.	Amt Applied	Description	Approver	Check No.	Date Paid	Amt Check
29TH STREET TAG AGENCY - #8822	Revenue Fund	VO807883	87.50	FEE/ISSUANCE 35 PIKEPASS 06/2024	APERINGO	RRV00349338	7/8/2024	87.50
		Check RRV00349338:	87.50					
		<b>Total for 29TH STREET TAG AGENCY - #8822:</b>	<b>87.50</b>					
A T & T - 5094	Revenue Fund	VO809525	34.77	ACCT#1800-000-6199 TOLL MULIT LINES	JLYTLE	RRV00349959	7/25/2024	34.77
		Check RRV00349959:	34.77					
A T & T - 5094	Revenue Fund	VO810123	1.52	ACCT#1000-951-3085 918-379-6876 CR TPK	JLYTLE	RRV00350091	7/31/2024	7.65
		VO810124	2.27	ACCT#1000-972-8758 TPK SAPULPA TOLL				
		VO810122	3.86	ACCT#1000-085-5832 TOLL MULTI LINES				
		Check RRV00350091:	7.65					
<b>Total for A T &amp; T - 5094:</b>		<b>42.42</b>						
A+ GLASS	Revenue Fund	VO807885	37.50	FEE/ISSUANCE 15 PIKEPASS 06/2024	APERINGO	RRV00349339	7/8/2024	37.50
		Check RRV00349339:	37.50					
		<b>Total for A+ GLASS:</b>	<b>37.50</b>					
A-1 REFUSE L.L.C.	Revenue Fund	VO808680	250.00	SOLID WASTE/TRASH DISPOSAL	RDTAYLOR	RRV00349725	7/15/2024	250.00
		Check RRV00349725:	250.00					
		<b>Total for A-1 REFUSE L.L.C.:</b>	<b>250.00</b>					
A-J TAG AGENCY LLC-7263	Revenue Fund	VO807903	295.00	FEE/ISSUANCE 118 PIKEPASS 06/2024	APERINGO	RRV00349345	7/8/2024	295.00
		Check RRV00349345:	295.00					
		<b>Total for A-J TAG AGENCY LLC-7263:</b>	<b>295.00</b>					
A1 SERVICE OKLAHOMA OF EUFAULA	Revenue Fund	VO807886	57.50	FEE/ISSUANCE 23 PIKEPASS 06/2024	APERINGO	RRV00349340	7/8/2024	57.50
		Check RRV00349340:	57.50					
		<b>Total for A1 SERVICE OKLAHOMA OF EUFAULA:</b>	<b>57.50</b>					
AAA CLUB ALLIANCE	Revenue Fund	VO808512	37.50	FEE/ISSUANCE 15 PIKEPASS 06/2024	APERINGO	RRV00349709	7/12/2024	37.50
		Check RRV00349709:	37.50					
AAA CLUB ALLIANCE	Revenue Fund	VO808514	15.00	FEE/ISSUANCE 6 PIKEPASS 06/2024	APERINGO	RRV00349710	7/12/2024	15.00
		Check RRV00349710:	15.00					
AAA CLUB ALLIANCE	Revenue Fund	VO808517	35.00	FEE/ISSUANCE 14 PIKEPASS 06/2024	APERINGO	RRV00349711	7/12/2024	35.00
		Check RRV00349711:	35.00					
AAA CLUB ALLIANCE	Revenue Fund	VO808520	27.50	FEE/ISSUANCE 11 PIKEPASS 06/2024	APERINGO	RRV00349712	7/12/2024	27.50
		Check RRV00349712:	27.50					
AAA CLUB ALLIANCE	Revenue Fund	VO808518	15.00	FEE/ISSUANCE 6 PIKEPASS 06/2024	APERINGO	RRV00349713	7/12/2024	15.00
		Check RRV00349713:	15.00					

Vendor Name	Fund Desc	Voucher NO.	Amt Applied	Description	Approver	Check No.	Date Paid	Amt Check
AAA CLUB ALLIANCE	Revenue Fund	VO808516	<u>80.00</u>	FEE/ISSUANCE 32 PIKEPASS 06/2024	APERINGO	RRV00349714	7/12/2024	80.00
		Check RRV00349714:	80.00					
AAA CLUB ALLIANCE	Revenue Fund	VO808515	<u>32.50</u>	FEE/ISSUANCE 13 PIKEPASS 06/2024	APERINGO	RRV00349715	7/12/2024	32.50
		Check RRV00349715:	32.50					
AAA CLUB ALLIANCE	Revenue Fund	VO808519	<u>45.00</u>	FEE/ISSUANCE 18 PIKEPASS 06/2024	APERINGO	RRV00349716	7/12/2024	45.00
		Check RRV00349716:	45.00					
AAA CLUB ALLIANCE	Revenue Fund	VO808521	<u>7.50</u>	FEE/ISSUANCE 3 PIKEPASS 06/2024	APERINGO	RRV00349717	7/12/2024	7.50
		Check RRV00349717:	7.50					
		<b>Total for AAA CLUB ALLIANCE:</b>	<b>295.00</b>					
ABSOLUTE EXTERMINATION	Revenue Fund	VO807912	<u>500.00</u>	PEST CONTROL SERVICES	CHUGHES	RRV00349499	7/10/2024	1,025.00
		VO807978	<u>525.00</u>	PEST CONTROL SERVICES	CHUGHES			
		Check RRV00349499:	1,025.00					
		<b>Total for ABSOLUTE EXTERMINATION:</b>	<b>1,025.00</b>					
ACE HARDWARE-ANTLERS	Revenue Fund	VO808687	<u>12.48</u>	SMALL TOOLS & EQUIPEMENT	BELLIS	RRV00349726	7/15/2024	12.48
		Check RRV00349726:	12.48					
		<b>Total for ACE HARDWARE-ANTLERS:</b>	<b>12.48</b>					
ACE TOWN AND COUNTRY	Revenue Fund	VO807442	<u>19.96</u>	BUILDING MAINTENANCE SUPPLIES	DCRAIG	RRV00349302	7/5/2024	19.96
		Check RRV00349302:	19.96					
ACE TOWN AND COUNTRY	Revenue Fund	VO807980	<u>16.99</u>	OTHER COMMODITES & SUPPLIES	DCRAIG	RRV00349500	7/10/2024	16.99
		Check RRV00349500:	16.99					
ACE TOWN AND COUNTRY	Revenue Fund	VO808682	<u>79.98</u>	SMALL TOOLS & EQUIPMENT	DCRAIG	RRV00349727	7/15/2024	106.97
		VO808685	<u>26.99</u>	SMALL TOOLS & EQUIPMENT	DCRAIG			
		Check RRV00349727:	106.97					
ACE TOWN AND COUNTRY	Revenue Fund	VO809319	<u>25.97</u>	BUILDING MAINTENANCE SUPPLIES	DCRAIG	RRV00349926	7/24/2024	29.96
		VO809320	<u>3.99</u>	BUILDING MAINTENANCE SUPPLIES	DCRAIG			
		Check RRV00349926:	29.96					
ACE TOWN AND COUNTRY	Revenue Fund	VO809875	<u>55.96</u>	SMALL TOOLS & EQUIPMENT	DCRAIG	RRV00350054	7/29/2024	85.90
		VO809867	<u>29.94</u>	CLEANING & JANITORIAL SUPPLIES	DCRAIG			
		Check RRV00350054:	85.90					
		<b>Total for ACE TOWN AND COUNTRY:</b>	<b>259.78</b>					
ACTION SAFETY SUPPLY CO.	Revenue Fund	VO810000	<u>22,702.40</u>	TRAFFIC CNTRL & SFTY SUPPLIES;00271868	SALLEN	REV00016075	7/29/2024	22,702.40
		Check REV00016075:	22,702.40					
ACTION SAFETY SUPPLY CO.	Reserve Maintenance	VO809681	<u>167,223.83</u>	NONCAP STRIPING / SVCS ; 00271658	JE4TGATZ	RMT00006054	7/26/2024	167,223.83
		Check RMT00006054:	167,223.83					
ACTION SAFETY SUPPLY CO.	Revenue Fund	VO807982	<u>480.00</u>	SIGNING SUPPLIES	PGOGGIN	RRV00349501	7/10/2024	480.00
		Check RRV00349501:	480.00					
ACTION SAFETY SUPPLY CO.	Revenue Fund	VO809278	<u>1,820.00</u>	STRIPING SERVICES	TGORE	RRV00349896	7/22/2024	1,820.00
		Check RRV00349896:	1,820.00					
		<b>Total for ACTION SAFETY SUPPLY CO.:</b>	<b>192,226.23</b>					

Vendor Name	Fund Desc	Voucher NO.	Amt Applied	Description	Approver	Check No.	Date Paid	Amt Check
ADA TAG AGENCY	Revenue Fund	VO807888	105.00	FEE/ISSUANCE 42 PIKEPASS 06/2024	APERINGO	RRV00349343	7/8/2024	105.00
		Check RRV00349343:	105.00					
		<b>Total for ADA TAG AGENCY:</b>	<b>105.00</b>					
ADAIR TAG AGENCY, #4918	Revenue Fund	VO807895	80.00	FEE/ISSUANCE 32 PIKEPASS 06/2024	APERINGO	RRV00349342	7/8/2024	80.00
		Check RRV00349342:	80.00					
		<b>Total for ADAIR TAG AGENCY, #4918:</b>	<b>80.00</b>					
ADAM TRUE VALUE & AG SUPPLY	Revenue Fund	VO809327	20.00	EQUIPMENT PARTS & SUPPLIES	BWESTER	RRV00349927	7/24/2024	20.00
		Check RRV00349927:	20.00					
		<b>Total for ADAM TRUE VALUE &amp; AG SUPPLY:</b>	<b>20.00</b>					
ADDISON GROUP	General	VO808265	3,060.00	OTHER PROFESSIONAL SVCS ; 10872738	DMA4TGAT	GEN00021466	7/11/2024	30,874.00
		VO808266	3,760.00	OTHER PROFESSIONAL SVCS ; 10872740	DMA4TGAT			
		VO808267	175.20	OTHER PROFESSIONAL SVCS ; 10872741	DMA4TGAT			
		VO808272	3,760.00	OTHER PROFESSIONAL SVCS ; 10876438	DMA4TGAT			
		VO808270	4,000.00	OTHER PROFESSIONAL SVCS ; 10872745	DMA4TGAT			
		VO808271	3,060.00	OTHER PROFESSIONAL SVCS ; 10876436	DMA4TGAT			
		VO808274	2,454.40	OTHER PROFESSIONAL SVCS ; 10876441	DMA4TGAT			
		VO808268	2,454.40	OTHER PROFESSIONAL SVCS ; 10872743	DMA4TGAT			
		VO808269	2,200.00	OTHER PROFESSIONAL SVCS ; 10872744	DMA4TGAT			
		VO808273	450.00	OTHER PROFESSIONAL SVCS ; 10876439	DMA4TGAT			
		VO808276	3,300.00	OTHER PROFESSIONAL SVCS ; 10876443	DMA4TGAT			
		VO808275	2,200.00	OTHER PROFESSIONAL SVCS ; 10876442	DMA4TGAT			
		Check GEN00021466:	30,874.00					
ADDISON GROUP	General	VO809323	3,760.00	OTHER PROFESSIONAL SVCS ; 10879971	DMA4TGAT	GEN00021508	7/24/2024	15,594.40
		VO809324	120.00	OTHER PROFESSIONAL SVCS ; 10879972	DMA4TGAT			
		VO809322	3,060.00	OTHER PROFESSIONAL SVCS ; 10879969	DMA4TGAT			
		VO809325	2,454.40	OTHER PROFESSIONAL SVCS ; 10879974	DMA4TGAT			
		VO809328	4,000.00	OTHER PROFESSIONAL SVCS ; 10879976	DMA4TGAT			
		VO809326	2,200.00	OTHER PROFESSIONAL SVCS ; 10879975	DMA4TGAT			
		Check GEN00021508:	15,594.40					
ADDISON GROUP	General	VO809601	3,008.00	OTHER PROFESSIONAL SVCS ; 10883954	DMA4TGAT	GEN00021517	7/25/2024	22,493.40
		VO809602	240.00	OTHER PROFESSIONAL SVCS ; 10883955	DMA4TGAT			
		VO809605	4,000.00	OTHER PROFESSIONAL SVCS ; 10883957	DMA4TGAT			
		VO809611	4,000.00	OTHER PROFESSIONAL SVCS ; 10887427	DMA4TGAT			
		VO809594	1,836.00	OTHER PROFESSIONAL SVCS ; 10883952	DMA4TGAT			
		VO809608	135.00	OTHER PROFESSIONAL SVCS ; 10887424	DMA4TGAT			
		VO809606	3,060.00	OTHER PROFESSIONAL SVCS ; 10887421	DMA4TGAT			
		VO809607	3,760.00	OTHER PROFESSIONAL SVCS ; 10887423	DMA4TGAT			
		VO809610	2,454.40	OTHER PROFESSIONAL SVCS ; 10887426	DMA4TGAT			
		Check GEN00021517:	22,493.40					
ADDISON GROUP	Revenue Fund	VO807988	723.75	OTHER PROFESSIONAL SERVICES	MGARDNER	RRV00349502	7/10/2024	6,607.50
		VO807989	2,580.00	OTHER PROFESSIONAL SERVICES - IT	ABOULDEN			
		VO807986	723.75	OTHER PROFESSIONAL SERVICES	MGARDNER			
		VO807991	2,580.00	OTHER PROFESSIONAL SERVICES - IT	ABOULDEN			
		Check RRV00349502:	6,607.50					
ADDISON GROUP	Revenue Fund	VO808696	2,580.00	OTHER PROFESSIONAL SERVICES - IT	ABOULDEN	RRV00349728	7/15/2024	4,056.00
		VO808691	1,476.00	OTHER PROFESSIONAL SERVICES	MGARDNER			

Vendor Name	Fund Desc	Voucher NO.	Amt Applied	Description	Approver	Check No.	Date Paid	Amt Check
		Check RRV00349728:	4,056.00					
ADDISON GROUP	Revenue Fund	VO809339	1,309.95	OTHER PROFESSIONAL SERVICES	MGARDNER	RRV00349928	7/24/2024	6,836.04
		VO809341	1,476.00	OTHER PROFESSIONAL SERVICES	MGARDNER			
		VO809342	2,580.00	OTHER PROFESSIONAL SERVICES - IT	ABOULDEN			
		VO809337	731.86	OTHER PROFESSIONAL SERVICES	MGARDNER			
		VO809338	738.23	OTHER PROFESSIONAL SERVICES	MGARDNER			
		Check RRV00349928:	6,836.04					
ADDISON GROUP	Revenue Fund	VO809894	2,580.00	OTHER PROFESSIONAL SERVICES - IT	ABOULDEN	RRV00350056	7/29/2024	2,580.00
		Check RRV00350056:	2,580.00					
		<b>Total for ADDISON GROUP:</b>	<b>89,041.34</b>					
ADMIRAL EXPRESS, LLC - TULSA	Revenue Fund	VO807992	5,428.55	NONCAPITALIZABLE OFFICE FURNITURE	TJDILL	RRV00349503	7/10/2024	5,428.55
		Check RRV00349503:	5,428.55					
		<b>Total for ADMIRAL EXPRESS, LLC - TULSA:</b>	<b>5,428.55</b>					
ADMIRAL TAG AGENCY	Revenue Fund	VO807896	190.00	FEE/ISSUANCE 76 PIKEPASS 06/2024	APERINGO	RRV00349344	7/8/2024	190.00
		Check RRV00349344:	190.00					
		<b>Total for ADMIRAL TAG AGENCY:</b>	<b>190.00</b>					
ADT COMMERCIAL LLC	Revenue Fund	VO809895	667.55	ALARM MONITORING SERVICES	RDTAYLOR	RRV00350057	7/29/2024	667.55
		Check RRV00350057:	667.55					
		<b>Total for ADT COMMERCIAL LLC:</b>	<b>667.55</b>					
ADVANCED WORKZONE SERVICES	Revenue Fund	VO807448	1,368.00	NONCAPITALIZABLE SIGNS & STRIPING	MCOLLINS	RRV00349303	7/5/2024	3,015.50
		VO807453	1,647.50	NONCAPITALIZABLE SIGNS & STRIPING	MCOLLINS			
		Check RRV00349303:	3,015.50					
ADVANCED WORKZONE SERVICES	Revenue Fund	VO808017	2,340.00	TRAFFIC CONTROL & SAFETY SUPPLIES	MCOLLINS	RRV00349504	7/10/2024	2,715.00
		VO808061	375.00	TRAFFIC CONTROL & SAFETY SUPPLIES	DCRAIG			
		Check RRV00349504:	2,715.00					
		<b>Total for ADVANCED WORKZONE SERVICES:</b>	<b>5,730.50</b>					
AIRGAS USA, LLC	Revenue Fund	VO808067	229.47	EQUIPMENT RENTAL	PGOGGIN	RRV00349505	7/10/2024	468.24
		VO808070	238.77	EQUIPMENT RENTAL	PGOGGIN			
		Check RRV00349505:	468.24					
		<b>Total for AIRGAS USA, LLC:</b>	<b>468.24</b>					
ALFALFA COUNTY TAG AGENCY, LLC	Revenue Fund	VO807907	17.50	FEE/ISSUANCE 7 PIKEPASS 06/2024	APERINGO	RRV00349346	7/8/2024	17.50
		Check RRV00349346:	17.50					
		<b>Total for ALFALFA COUNTY TAG AGENCY, LLC:</b>	<b>17.50</b>					
ALL AMERICAN FIRE SYSTEMS, INC.	Revenue Fund	VO807457	852.00	OTHER MAINTENANCE & ACCT. RECEIVABLE	JECHELLE	RRV00349304	7/5/2024	852.00
		Check RRV00349304:	852.00					
		<b>Total for ALL AMERICAN FIRE SYSTEMS, INC.:</b>	<b>852.00</b>					
ALTUS TAG AGENCY	Revenue Fund	VO807897	152.50	FEE/ISSUANCE 61 PIKEPASS 06/2024	APERINGO	RRV00349347	7/8/2024	152.50
		Check RRV00349347:	152.50					
		<b>Total for ALTUS TAG AGENCY:</b>	<b>152.50</b>					
AMERICAN ELECTRIC POWER	Revenue Fund	VO807566	1,221.55	ELECTRIC	BPATTERS	EFT018743	7/2/2024	2,789.00
		VO807567	1,567.45	ELECTRIC	BPATTERS			
		Check EFT018743:	2,789.00					

Vendor Name	Fund Desc	Voucher NO.	Amt Applied	Description	Approver	Check No.	Date Paid	Amt Check
AMERICAN ELECTRIC POWER	Revenue Fund	VO807587	2,626.17	ELECTRIC	BPATTERS BPATTERS	EFT018744	7/2/2024	4,763.27
		VO807584	2,137.10	ELECTRIC				
		Check EFT018744:	4,763.27					
AMERICAN ELECTRIC POWER	Revenue Fund	VO807660	9,701.62	ELECTRIC	BPATTERS	EFT018752	7/3/2024	9,701.62
		Check EFT018752:	9,701.62					
AMERICAN ELECTRIC POWER	Revenue Fund	VO807662	1,904.78	ELECTRIC	BPATTERS BPATTERS	EFT018753	7/3/2024	3,183.60
		VO807664	1,278.82	ELECTRIC				
		Check EFT018753:	3,183.60					
AMERICAN ELECTRIC POWER	Revenue Fund	VO807665	2,287.37	ELECTRIC	BPATTERS BPATTERS BPATTERS	EFT018754	7/3/2024	6,393.49
		VO807668	1,247.69	ELECTRIC				
		VO807672	2,858.43	ELECTRIC				
		Check EFT018754:	6,393.49					
AMERICAN ELECTRIC POWER	Revenue Fund	VO808186	3,536.32	ELECTRIC	BPATTERS BPATTERS	EFT018786	7/10/2024	4,132.45
		VO808184	596.13	ELECTRIC				
		Check EFT018786:	4,132.45					
AMERICAN ELECTRIC POWER	Revenue Fund	VO808198	1,100.23	ELECTRIC	BPATTERS BPATTERS	EFT018787	7/10/2024	2,882.38
		VO808200	1,782.15	ELECTRIC				
		Check EFT018787:	2,882.38					
AMERICAN ELECTRIC POWER	Revenue Fund	VO808218	1,075.45	ELECTRIC	BPATTERS BPATTERS BPATTERS BPATTERS	EFT018788	7/10/2024	4,111.31
		VO808213	652.48	ELECTRIC				
		VO808214	395.42	ELECTRIC				
		VO808216	992.48	ELECTRIC				
		VO808220	995.48	ELECTRIC				
Check EFT018788:	4,111.31							
AMERICAN ELECTRIC POWER	Revenue Fund	VO808316	12,665.91	ELECTRIC	BPATTERS	EFT018791	7/11/2024	12,665.91
		Check EFT018791:	12,665.91					
AMERICAN ELECTRIC POWER	Revenue Fund	VO808498	708.31	ELECTRIC	BPATTERS BPATTERS BPATTERS BPATTERS BPATTERS	EFT018796	7/12/2024	2,500.05
		VO808501	185.99	ELECTRIC				
		VO808503	183.31	ELECTRIC				
		VO808502	210.41	ELECTRIC				
		VO808499	147.63	ELECTRIC				
		VO808500	1,064.40	ELECTRIC				
Check EFT018796:	2,500.05							
AMERICAN ELECTRIC POWER	Revenue Fund	VO808663	345.86	ELECTRIC	BPATTERS	EFT018800	7/15/2024	345.86
		Check EFT018800:	345.86					
AMERICAN ELECTRIC POWER	Revenue Fund	VO808822	841.01	ELECTRIC	BPATTERS BPATTERS BPATTERS BPATTERS BPATTERS BPATTERS	EFT018811	7/16/2024	3,921.45
		VO808824	263.97	ELECTRIC				
		VO808827	800.18	ELECTRIC				
		VO808828	1,009.84	ELECTRIC				
		VO808830	632.06	ELECTRIC				
		VO808825	172.06	ELECTRIC				
		VO808829	21.22	ELECTRIC				
VO808831	181.11	ELECTRIC						

Vendor Name	Fund Desc	Voucher NO.	Amt Applied	Description	Approver	Check No.	Date Paid	Amt Check
		Check EFT018811:	3,921.45					
AMERICAN ELECTRIC POWER	Revenue Fund	VO809550	30.20	ELECTRIC	BPATTERS	EFT018814	7/25/2024	1,178.12
		VO809552	1,147.92	ELECTRIC	BPATTERS			
		Check EFT018814:	1,178.12					
		<b>Total for AMERICAN ELECTRIC POWER:</b>	<b>58,568.51</b>					
AMERICAN LOGO & SIGN, INC	Revenue Fund	VO807468	528.00	NONCAPITALIZABLE SIGNS & STRIPING	KWALLIS	RRV00349306	7/5/2024	528.00
		Check RRV00349306:	528.00					
AMERICAN LOGO & SIGN, INC	Revenue Fund	VO808698	74.50	NONCAP SIGNS & OTHER SUPPLIES	PGOGGIN	RRV00349730	7/15/2024	194.50
		VO808697	120.00	NONCAPITALIZABLE SIGNS & STRIPING	PGOGGIN			
		Check RRV00349730:	194.50					
		<b>Total for AMERICAN LOGO &amp; SIGN, INC:</b>	<b>722.50</b>					
AMERICAN PARKING, INC.	Revenue Fund	VO807898	82.50	FEE/ISSUANCE 33 PIKEPASS 06/2024	APERINGO	RRV00349749	7/16/2024	82.50
		Check RRV00349749:	82.50					
		<b>Total for AMERICAN PARKING, INC.:</b>	<b>82.50</b>					
AMERICAN SELF STORAGE	Revenue Fund	VO808071	160.00	BUILDING & REAL ESTATE RENTAL	AHEITZ	RRV00349507	7/10/2024	160.00
		Check RRV00349507:	160.00					
		<b>Total for AMERICAN SELF STORAGE:</b>	<b>160.00</b>					
AMERICAN STAFFCORP OF OKC, LLC	Revenue Fund	VO808490	47,856.45	TEMPORARY PERSONNEL SVCS ; 8211721	BJEPSEN	REV00016028	7/12/2024	128,085.99
		VO808489	13,656.35	TEMPORARY PERSONNEL SVCS ; 21812	BJEPSEN			
		VO808488	14,951.91	TEMPORARY PERSONNEL SVCS ; 21796	BJEPSEN			
		VO808491	51,621.28	TEMPORARY PERSONNEL SVCS ; 8211795	BJEPSEN			
		Check REV00016028:	128,085.99					
AMERICAN STAFFCORP OF OKC, LLC	Revenue Fund	VO809262	50,142.94	TEMPORARY PERSONNEL SVCS; 8211949	BJEPSEN	REV00016059	7/19/2024	62,783.02
		VO809263	12,069.84	TEMPORARY PERSONNEL SVCS; 21829	BJEPSEN			
		VO809265	570.24	TEMPORARY PERSONNEL SVCS; 21882	SALLEN			
		Check REV00016059:	62,783.02					
AMERICAN STAFFCORP OF OKC, LLC	Revenue Fund	VO810003	14,015.55	TEMPORARY PERSONNEL SVCS ; 21865	BJEPSEN	REV00016076	7/29/2024	79,633.97
		VO810004	14,139.47	TEMPORARY PERSONNEL SVCS ; 21881	BJEPSEN			
		VO810005	51,478.95	TEMPORARY PERSONNEL SVCS ; 8212154	BJEPSEN			
		Check REV00016076:	79,633.97					
AMERICAN STAFFCORP OF OKC, LLC	Revenue Fund	VO807475	950.40	TEMPORARY PERSONNEL SERVICES	JSMITH	RRV00349305	7/5/2024	950.40
		Check RRV00349305:	950.40					
AMERICAN STAFFCORP OF OKC, LLC	Revenue Fund	VO809358	950.40	TEMPORARY PERSONNEL SERVICES	JSMITH	RRV00349931	7/24/2024	950.40
		Check RRV00349931:	950.40					
		<b>Total for AMERICAN STAFFCORP OF OKC, LLC:</b>	<b>272,403.78</b>					
AMERICAN WASTE CONTROL INC.	Revenue Fund	VO808087	345.00	EQUIPMENT RENTAL & TRASH DISPOSAL	JJENKINS	RRV00349506	7/10/2024	778.92
		VO808075	83.73	SOLID WASTE/TRASH DISPOSAL & FIN SRVCS	AHEITZ			
		VO808080	350.19	EQUIP RENTAL TRASH DISPOSAL & FIN SRVCS	JJENKINS			
		Check RRV00349506:	778.92					
AMERICAN WASTE CONTROL INC.	Revenue Fund	VO808705	60.00	EQUIPMENT RENTAL	RDTAYLOR	RRV00349729	7/15/2024	60.00
		Check RRV00349729:	60.00					
		<b>Total for AMERICAN WASTE CONTROL INC.:</b>	<b>838.92</b>					

Vendor Name	Fund Desc	Voucher NO.	Amt Applied	Description	Approver	Check No.	Date Paid	Amt Check
AMERICAN WELDING SUPPLY, INC	Revenue Fund	VO808710	39.60	EQUIPMENT RENTAL	RDTAYLOR	RRV00349731	7/15/2024	39.60
		Check RRV00349731:	39.60					
AMERICAN WELDING SUPPLY, INC	Revenue Fund	VO809343	155.42	WELDING SUPPLIES	RDTAYLOR	RRV00349932	7/24/2024	155.42
		Check RRV00349932:	155.42					
<b>Total for AMERICAN WELDING SUPPLY, INC:</b>			<b>195.02</b>					
AMERIFLEX HOSE & ACCESSORIES	Revenue Fund	VO809355	68.90	VEHICLE PARTS & SUPPLIES	DCRAIG	RRV00349930	7/24/2024	68.90
		Check RRV00349930:	68.90					
<b>Total for AMERIFLEX HOSE &amp; ACCESSORIES:</b>			<b>68.90</b>					
ANTLERS HARDWARE, INC.	Revenue Fund	VO808711	90.36	OTHER COMMODITIES & SUPPLIES	BELLIS	RRV00349732	7/15/2024	90.36
		Check RRV00349732:	90.36					
<b>Total for ANTLERS HARDWARE, INC.:</b>			<b>90.36</b>					
ANTLERS PUBLIC WORKS AUTHORITY	Revenue Fund	VO807594	68.05	WATER	BPATTERS	EFT018745	7/2/2024	68.05
		Check EFT018745:	68.05					
<b>Total for ANTLERS PUBLIC WORKS AUTHORITY:</b>			<b>68.05</b>					
ANTLERS TAG OFFICE - RITA JOHNSO	Revenue Fund	VO807899	32.50	FEE/ISSUANCE 13 PIKEPASS 06/2024	APERINGO	RRV00349349	7/8/2024	32.50
		Check RRV00349349:	32.50					
<b>Total for ANTLERS TAG OFFICE - RITA JOHNSON #6416:</b>			<b>32.50</b>					
APAC-CENTRAL, INC.	General	VO808259	484,306.02	WR-MC-139: ESTIMATE NO. 1	TJD4JECH	GEN00021465	7/11/2024	484,306.02
		Check GEN00021465:	484,306.02					
APAC-CENTRAL, INC.	Revenue Fund	VO809356	929.22	CONCRETE & ASPHALT SUPPLIES	RDTAYLOR	RRV00349933	7/24/2024	1,717.22
		VO809357	788.00	ASPHALT & CONCRETE SUPPLIES				
		Check RRV00349933:	1,717.22					
APAC-CENTRAL, INC.	Revenue Fund	VO809896	1,421.40	DRAINAGE & CULVERTS	MCCOLLINS	RRV00350058	7/29/2024	1,421.40
		Check RRV00350058:	1,421.40					
<b>Total for APAC-CENTRAL, INC.:</b>			<b>487,444.64</b>					
APEX SYSTEMS LLC	General	VO808277	8,712.00	OTHER PROFESSIONAL SVCS ; 0007991632	DMA4TGAT	GEN00021467	7/11/2024	8,712.00
		Check GEN00021467:	8,712.00					
<b>Total for APEX SYSTEMS LLC:</b>			<b>8,712.00</b>					
ARCADIA TAG & TITLE - VIOLA DAVIS	Revenue Fund	VO807900	10.00	FEE/ISSUANCE 4 PIKEPASS 06/2024	APERINGO	RRV00349350	7/8/2024	10.00
		Check RRV00349350:	10.00					
<b>Total for ARCADIA TAG &amp; TITLE - VIOLA DAVIS #5597:</b>			<b>10.00</b>					
ARDMORE TAG OFFICE	Revenue Fund	VO807901	25.00	FEE/ISSUANCE 10 PIKEPASS 06/20204	APERINGO	RRV00349351	7/8/2024	25.00
		Check RRV00349351:	25.00					
<b>Total for ARDMORE TAG OFFICE:</b>			<b>25.00</b>					
ARKOMA TAG AGENCY	Revenue Fund	VO807914	30.00	FEE/ISSUANCE 12 PIKEPASS 06/2024	APERINGO	RRV00349352	7/8/2024	30.00
		Check RRV00349352:	30.00					
<b>Total for ARKOMA TAG AGENCY:</b>			<b>30.00</b>					
ARTISAN WINDOW CLEANING	Revenue Fund	VO808094	2,857.00	OTHER CONTRACTUAL SERVICES	TJDILL	RRV00349508	7/10/2024	2,857.00
		Check RRV00349508:	2,857.00					
<b>Total for ARTISAN WINDOW CLEANING:</b>			<b>2,857.00</b>					

Vendor Name	Fund Desc	Voucher NO.	Amt Applied	Description	Approver	Check No.	Date Paid	Amt Check
AS PLUMBING- ACTS OF SERVICE PLL	Revenue Fund	VO809844	<u>4,463.00</u>	BUILD MAINT SUPP; BUILD MAINT SERV	TGORE	RRV00350040	7/26/2024	4,463.00
		Check RRV00350040:	<u>4,463.00</u>					
		<b>Total for AS PLUMBING- ACTS OF SERVICE PLUMBING:</b>	<b>4,463.00</b>					
ASAP MAIL MART LLC	Revenue Fund	VO807917	<u>45.00</u>	FEE/ISSUANCE 18 PIKEPASS 06-2024	APERINGO	RRV00349353	7/8/2024	45.00
		Check RRV00349353:	<u>45.00</u>					
		<b>Total for ASAP MAIL MART LLC:</b>	<b>45.00</b>					
AT&T - 5001	Revenue Fund	VO807910	<u>269.98</u>	PHONE SERVICE 405 A61 0796 161	JLYTLE	EFT018770	7/8/2024	269.98
		Check EFT018770:	<u>269.98</u>					
AT&T - 5001	Revenue Fund	VO808358	<u>325.31</u>	PHONE # 405-A01-0797-166-5	JLYTLE	EFT018790	7/11/2024	1,242.49
		VO808362	<u>917.18</u>	PHONE 918-A04-0722-168-8	BPATTERS			
		Check EFT018790:	<u>1,242.49</u>					
AT&T - 5001	Revenue Fund	VO808653	<u>512.88</u>	PHONE 405-A01-0012-011-2	JLYTLE	EFT018798	7/15/2024	512.88
		Check EFT018798:	<u>512.88</u>					
		<b>Total for AT&amp;T - 5001:</b>	<b>2,025.35</b>					
AT&T MOBILITY - PO BOX 6463	Revenue Fund	VO808922	<u>13,515.45</u>	287289509784 57722625 WIRELESS SERVICE	JLYTLE	EFT018813	7/17/2024	13,515.45
		Check EFT018813:	<u>13,515.45</u>					
		<b>Total for AT&amp;T MOBILITY - PO BOX 6463:</b>	<b>13,515.45</b>					
ATKINS NORTH AMERICA, INC.	Capital Projects	VO809680	<u>62,375.00</u>	T-MC-131: CON MGR/RES ENG/TST: 2020144	TJDILL	23A0000241	7/26/2024	62,375.00
		Check 23A0000241:	<u>62,375.00</u>					
ATKINS NORTH AMERICA, INC.	General	VO808166	<u>4,077.47</u>	HEB-MC-67B: AET-002: AET CNVRSN: 2020149	JGARDER	GEN00021459	7/10/2024	4,077.47
		Check GEN00021459:	<u>4,077.47</u>					
ATKINS NORTH AMERICA, INC.	Reserve Maintenance	VO808656	<u>812.48</u>	AET CNVRSION PRJ, CHEROKEE ; 2019227	DMA4TGAT	RMT00006045	7/15/2024	2,887.38
		VO808657	<u>2,074.90</u>	AET CNVRSION PROJ, HEB ; 2019236	DMA4TGAT			
		Check RMT00006045:	<u>2,887.38</u>					
		<b>Total for ATKINS NORTH AMERICA, INC.:</b>	<b>69,339.85</b>					
ATLAS STEEL PRODUCTS, INC.	Revenue Fund	VO809898	<u>20.00</u>	FENCING SUPPLIES	DCRAIG	RRV00350059	7/29/2024	40.00
		VO809897	<u>20.00</u>	FENCING SUPPLIES	DCRAIG			
		Check RRV00350059:	<u>40.00</u>					
		<b>Total for ATLAS STEEL PRODUCTS, INC.:</b>	<b>40.00</b>					
ATLAS TELEPHONE COMPANY, INC	Revenue Fund	VO807652	<u>38.63</u>	ACCT#9902002241 WR TPK MAINLINE GATE	JLYTLE	RRV00349241	7/3/2024	73.76
		VO807653	<u>35.13</u>	ACCT#0210005308 WR TPK BIG CABIN TOLL	JLYTLE			
		Check RRV00349241:	<u>73.76</u>					
		<b>Total for ATLAS TELEPHONE COMPANY, INC:</b>	<b>73.76</b>					
ATOKA TAG AGE- AFTER 8/5/24 USE	Revenue Fund	VO807919	<u>7.50</u>	FEE/ISSUANCE 3 PIKEPASS 06/2024	APERINGO	RRV00349354	7/8/2024	7.50
		Check RRV00349354:	<u>7.50</u>					
		<b>Total for ATOKA TAG AGE- AFTER 8/5/24 USE ATOTAG02:</b>	<b>7.50</b>					
ATWOODS - BROKEN ARROW	Revenue Fund	VO807491	<u>4.99</u>	OTHER COMMODITIES & SUPPLIES	JJENKINS	RRV00349310	7/5/2024	20.55
		VO807511	<u>15.56</u>	ASPHALT & CONCRETE SUPPLIES	JJENKINS			
		Check RRV00349310:	<u>20.55</u>					
ATWOODS - BROKEN ARROW	Revenue Fund	VO809386	<u>244.88</u>	EQUIPMENT, OTHER MAINT & OTHER SUPPLIES	JJENKINS	RRV00349936	7/24/2024	425.23



Vendor Name	Fund Desc	Voucher NO.	Amt Applied	Description	Approver	Check No.	Date Paid	Amt Check
		VO809391	175.88	EQUIPMENT, OTHER MAINT & OTHER SUPPLIES	JJENKINS			
		VO809384	4.47	ASPHALT & CONCRETE SUPPLIES	JJENKINS			
		Check RRV00349936:	425.23					
		<b>Total for ATWOODS - BROKEN ARROW:</b>	<b>445.78</b>					
ATWOODS - CHANDLER	Revenue Fund	VO807489	87.98	OTHER COMMODITIES & SUPPLIES	RDTAYLOR	RRV00349311	7/5/2024	87.98
		Check RRV00349311:	87.98					
		<b>Total for ATWOODS - CHANDLER:</b>	<b>87.98</b>					
ATWOODS - CHICKASHA	Revenue Fund	VO808720	167.38	OTHER COMMODITIES & SUPPLIES	KWALLIS	RRV00349735	7/15/2024	355.02
		VO808793	162.69	OTHER COMMODITIES & SUPPLIES	KWALLIS			
		VO808795	24.95	OTHER COMMODITIES & SUPPLIES	KWALLIS			
		Check RRV00349735:	355.02					
		<b>Total for ATWOODS - CHICKASHA:</b>	<b>355.02</b>					
ATWOODS - CLAREMORE	Revenue Fund	VO807508	13.38	HARDWARE	DCRAIG	RRV00349312	7/5/2024	13.38
		Check RRV00349312:	13.38					
		<b>Total for ATWOODS - CLAREMORE:</b>	<b>13.38</b>					
ATWOODS - MCALESTER	Revenue Fund	VO807500	77.95	OTHER COMMODITIES & SUPPLIES	BWESTER	RRV00349308	7/5/2024	77.95
		Check RRV00349308:	77.95					
ATWOODS - MCALESTER	Revenue Fund	VO808779	429.99	NONCAPITALIZABLE EQUIPMENT	BELLIS	RRV00349734	7/15/2024	653.90
		VO808784	159.92	ASPHALT & CONCRETE SUPPLIES	BELLIS			
		VO808790	63.99	SMALL TOOLS & EQUIPMENT	BELLIS			
		Check RRV00349734:	653.90					
ATWOODS - MCALESTER	Revenue Fund	VO809392	19.98	EQUIPMENT PARTS & SUPPLIES	BWESTER	RRV00349934	7/24/2024	19.98
		Check RRV00349934:	19.98					
ATWOODS - MCALESTER	Revenue Fund	VO809923	169.99	FENCING SUPPLIES	BWESTER	RRV00350060	7/29/2024	169.99
		Check RRV00350060:	169.99					
		<b>Total for ATWOODS - MCALESTER:</b>	<b>921.82</b>					
ATWOODS - MUSTANG	Revenue Fund	VO807764	30.30	OTHER MAINTENANCE SUPPLIES	PGOGGIN	RRV00349314	7/5/2024	30.30
		Check RRV00349314:	30.30					
		<b>Total for ATWOODS - MUSTANG:</b>	<b>30.30</b>					
ATWOODS - SAPULPA	Revenue Fund	VO809373	34.90	EQUIPMENT PARTS & SUPPLIES	RDTAYLOR	RRV00349935	7/24/2024	34.90
		Check RRV00349935:	34.90					
		<b>Total for ATWOODS - SAPULPA:</b>	<b>34.90</b>					
ATWOODS - SHAWNEE	Revenue Fund	VO808751	8.49	EQUIPMENT PARTS & SUPPLIES	JSMART	RRV00349736	7/15/2024	8.49
		Check RRV00349736:	8.49					
ATWOODS - SHAWNEE	Revenue Fund	VO809377	128.61	EQUIPMENT PARTS & SUPPLIES	JSMART	RRV00349937	7/24/2024	128.61
		Check RRV00349937:	128.61					
		<b>Total for ATWOODS - SHAWNEE:</b>	<b>137.10</b>					
ATWOODS - STILLWATER	Revenue Fund	VO807497	19.99	INSECTICIDES & HERBICIDES	RROWEN	RRV00349307	7/5/2024	19.99
		Check RRV00349307:	19.99					
ATWOODS - STILLWATER	Revenue Fund	VO781161	360.51	HERBICIDE & CANDY	RROWEN	RRV00349680	7/12/2024	360.51
		Check RRV00349680:	360.51					

Vendor Name	Fund Desc	Voucher NO.	Amt Applied	Description	Approver	Check No.	Date Paid	Amt Check
ATWOODS - STILLWATER	Revenue Fund	VO808754	239.97	SMALL TOOLS & EQUIPMENT	RROWEN	RRV00349733	7/15/2024	239.97
		Check RRV00349733:	239.97					
		<b>Total for ATWOODS - STILLWATER:</b>	<b>620.47</b>					
ATWOODS - VINITA	Revenue Fund	VO807504	23.97	EQUIPMENT PARTS & SMALL TOOLS	DCRAIG	RRV00349309	7/5/2024	23.97
		Check RRV00349309:	23.97					
ATWOODS - VINITA	Revenue Fund	VO808097	85.97	EQUIPMENT PARTS & SUPPLIES	DCRAIG	RRV00349509	7/10/2024	85.97
		Check RRV00349509:	85.97					
		<b>Total for ATWOODS - VINITA:</b>	<b>109.94</b>					
ATWOODS - YUKON	Revenue Fund	VO807481	178.90	EQUIPMENT PARTS & SUPPLIES	PGOGGIN	RRV00349313	7/5/2024	348.38
		VO807484	147.88	EQUIPMENT PATS & OTHER MAINT SUPPLIES				
		VO807487	21.60	EQUIPMENT PARTS & SUPPLIES				
		Check RRV00349313:	348.38					
ATWOODS - YUKON	Revenue Fund	VO808747	46.99	EQUIPMENT PARTS & SUPPLIES	PGOGGIN	RRV00349737	7/15/2024	71.98
		VO808729	24.99	EQUIPMENT PARTS & SUPPLIES				
		Check RRV00349737:	71.98					
ATWOODS - YUKON	Revenue Fund	VO809369	65.51	HARDWARE & VEHICLE SUPPLIES	PGOGGIN	RRV00349938	7/24/2024	390.65
		VO809372	325.14	SMALL TOOLS & OTHER SUPPLIES				
		Check RRV00349938:	390.65					
ATWOODS - YUKON	Revenue Fund	VO809899	11.98	EQUIPMENT PARTS & SUPPLIES	PGOGGIN	RRV00350061	7/29/2024	26.46
		VO809911	14.48	HARDWARE				
		Check RRV00350061:	26.46					
<b>Total for ATWOODS - YUKON:</b>		<b>837.47</b>						
AUTOGLASS OUTLET	Revenue Fund	VO807920	17.50	FEE/ISSUANCE 7 PIKEPASS 06/2024	APERINGO	RRV00349355	7/8/2024	17.50
		Check RRV00349355:	17.50					
		<b>Total for AUTOGLASS OUTLET:</b>	<b>17.50</b>					
AUTOMOTIVE SUPPLY COMPANY - V	Revenue Fund	VO807521	332.37	VEHICLE/EQUIPMENT PARTS & SUPPLIES	DCRAIG	RRV00349316	7/5/2024	515.45
		VO807523	22.08	EQUIPMENT/VEHICLE PARTS & SUPPLIES				
		VO807520	161.00	VEHICLE PARTS & SUPPLIES				
		Check RRV00349316:	515.45					
AUTOMOTIVE SUPPLY COMPANY - V	Revenue Fund	VO808116	19.82	EQUIPMENT PARTS & SUPPLIES	DCRAIG	RRV00349512	7/10/2024	28.10
		VO808115	8.28	VEHICLE PARTS & SUPPLIES				
		Check RRV00349512:	28.10					
AUTOMOTIVE SUPPLY COMPANY - V	Revenue Fund	VO808809	22.00	VEHICLE PARTS & SUPPLIES	DCRAIG	RRV00349781	7/17/2024	199.21
		VO808841	177.21	VEHICLE PARTS & SUPPLIES				
		Check RRV00349781:	199.21					
AUTOMOTIVE SUPPLY COMPANY - V	Revenue Fund	VO809393	40.60	VEHICLE PARTS & SUPPLIES	DCRAIG	RRV00349941	7/24/2024	40.60
		Check RRV00349941:	40.60					
AUTOMOTIVE SUPPLY COMPANY - V	Revenue Fund	VO809926	214.00	EQUIPMENT PARTS & SUPPLIES	DCRAIG	RRV00350064	7/29/2024	833.28
		VO809929	6.49	HARDWARE				
		VO809932	36.00	VEHICLE PARTS & SUPPLIES				
		VO809935	66.79	EQUIPMENT PARTS & SUPPLIES				

Vendor Name	Fund Desc	Voucher NO.	Amt Applied	Description	Approver	Check No.	Date Paid	Amt Check
		VO809937	510.00	VEHICLE PARTS & SUPPLIES	DCRAIG			
		Check RRV00350064:	833.28					
		<b>Total for AUTOMOTIVE SUPPLY COMPANY - V:</b>	<b>1,616.64</b>					
AUTOZONE-CHICKASHA	Revenue Fund	VO809394	580.00	SMALL TOOLS & OTHER MAINT SUPPLIES	KWALLIS	RRV00349939	7/24/2024	580.00
		Check RRV00349939:	580.00					
		<b>Total for AUTOZONE-CHICKASHA:</b>	<b>580.00</b>					
AWP SAFETY	Revenue Fund	VO807492	75.00	OTHER CONTRACTUAL SERVICES	JJENKINS	RRV00349277	7/5/2024	75.00
		Check RRV00349277:	75.00					
AWP SAFETY	Revenue Fund	VO809395	60.00	OTHER CONTRACTUAL SERVICES	JJENKINS	RRV00349929	7/24/2024	60.00
		Check RRV00349929:	60.00					
		<b>Total for AWP SAFETY:</b>	<b>135.00</b>					
B & B CONSTRUCTION SERVICE, INC. General		VO808042	6,748.00	IN-MC-67: ESTIMATE NO. 13	TJDILL	GEN00021455	7/9/2024	6,748.00
		Check GEN00021455:	6,748.00					
		<b>Total for B &amp; B CONSTRUCTION SERVICE, INC.:</b>	<b>6,748.00</b>					
BAILEY'S PAVING CO.	Revenue Fund	VO807525	888.74	ASPHALT & CONCRETE SUPPLIES	RDTAYLOR	RRV00349246	7/3/2024	5,735.74
		VO807526	984.20	ASPHALT & CONCRETE SUPPLIES	RDTAYLOR			
		VO807527	981.24	ASPHALT & CONCRETE SUPPLIES	RDTAYLOR			
		VO807528	950.16	ASPHALT & CONCRETE SUPPLIES	RDTAYLOR			
		VO807529	966.44	ASPHALT & CONCRETE SUPPLIES	RDTAYLOR			
		VO807530	964.96	ASPHALT & CONCRETE SUPPLIES	RDTAYLOR			
		Check RRV00349246:	5,735.74					
BAILEY'S PAVING CO.	Revenue Fund	VO808846	873.94	ASPHALT & CONCRETE SUPPLIES	RDTAYLOR	RRV00349764	7/17/2024	873.94
		Check RRV00349764:	873.94					
BAILEY'S PAVING CO.	Revenue Fund	VO809423	992.56	ASPHALT & CONCRETE SUPPLIES	RDTAYLOR	RRV00349949	7/24/2024	2,989.84
		VO809428	1,009.28	ASPHALT & CONCRETE SUPPLIES	MCOLLINS			
		VO809425	988.00	ASPHALT & CONCRETE SUPPLIES	RDTAYLOR			
		Check RRV00349949:	2,989.84					
		<b>Total for BAILEY'S PAVING CO.:</b>	<b>9,599.52</b>					
BARNES TAG AGENCY - 7282	Revenue Fund	VO807922	485.00	FEE/ISSUANCE 194 PIKEPASS 06/2024	APERINGO	RRV00349369	7/8/2024	485.00
		Check RRV00349369:	485.00					
		<b>Total for BARNES TAG AGENCY - 7282:</b>	<b>485.00</b>					
BARTLESVILLE TAG AGENCY	Revenue Fund	VO807923	135.00	FEE/ISSUANCE 54 PIKEPASS 06/2024	APERINGO	RRV00349356	7/8/2024	135.00
		Check RRV00349356:	135.00					
		<b>Total for BARTLESVILLE TAG AGENCY:</b>	<b>135.00</b>					
BATES TAG AGENCY	Revenue Fund	VO807926	45.00	FEE/ISSUANCE 18 PIKEPASS 06/2024	APERINGO	RRV00349357	7/8/2024	45.00
		Check RRV00349357:	45.00					
		<b>Total for BATES TAG AGENCY:</b>	<b>45.00</b>					
BEE CLEAN CLEANING SERVICE INC.	Revenue Fund	VO807532	320.00	CUSTODIAL SERVICES	BCANTREL	RRV00349247	7/3/2024	320.00
		Check RRV00349247:	320.00					
BEE CLEAN CLEANING SERVICE INC.	Revenue Fund	VO809940	320.00	CUSTODIAL SERVICES	BCANTREL	RRV00350062	7/29/2024	320.00
		Check RRV00350062:	320.00					
		<b>Total for BEE CLEAN CLEANING SERVICE INC.:</b>	<b>640.00</b>					

Vendor Name	Fund Desc	Voucher NO.	Amt Applied	Description	Approver	Check No.	Date Paid	Amt Check
BEMAC SUPPLY UNION IRON WRKS,	Revenue Fund	VO808849	151.47	SMALL TOOLS & EQUIPMENT	BELLIS	RRV00349765	7/17/2024	151.47
		Check RRV00349765:	151.47					
<b>Total for BEMAC SUPPLY UNION IRON WRKS, INC-MCALES:</b>			<b>151.47</b>					
BENCHMARK CONSTRUCTION SERVI	General	VO808905	87,529.59	WR-MC-144: CON MGT/PRJ MGR: INV# 4	TJDILL	GEN00021485	7/17/2024	87,529.59
		Check GEN00021485:	87,529.59					
<b>Total for BENCHMARK CONSTRUCTION SERVICES, LLC:</b>			<b>87,529.59</b>					
BENHAM DESIGN, LLC	Capital Projects	VO808839	113,182.00	T-26601A: RDWY/BRG DSGN: 1400351203-02R	TJDILL	23A0000229	7/16/2024	113,182.00
		Check 23A0000229:	113,182.00					
BENHAM DESIGN, LLC	Capital Projects	VO809316	70,000.00	T-26601A: RD DSGN: 1400351203-01R	DBUTLER	23A0000234	7/22/2024	445,451.00
		VO809313	30,000.00	T-26501A: RDWY DSGN: 1400351202-01R	DBUTLER			
		VO809315	107,000.00	T-26701A: RD/BRG DSGN: 1400351204-01R	TJDILL			
		VO809314	47,751.00	T-26501A: RD/BRG DSGN: 1400351202-02R	DBUTLER			
		VO809317	190,700.00	T-26701A: RD/BRDG DSGN: 1400351204-02R	TJDILL			
		Check 23A0000234:	445,451.00					
<b>Total for BENHAM DESIGN, LLC:</b>			<b>558,633.00</b>					
BETHANY TAG AGENCY, INC.	Revenue Fund	VO807927	82.50	FEE/ISSUANCE 33 PIKEPASS 06/2024	APERINGO	RRV00349359	7/8/2024	82.50
		Check RRV00349359:	82.50					
<b>Total for BETHANY TAG AGENCY, INC.:</b>			<b>82.50</b>					
BETHEL ACRES TAG AGENCY INC	Revenue Fund	VO807929	7.50	FEE/ISSUANCE 3 PIKEPASS 06/2024	APERINGO	RRV00349358	7/8/2024	7.50
		Check RRV00349358:	7.50					
<b>Total for BETHEL ACRES TAG AGENCY INC:</b>			<b>7.50</b>					
BIG CABIN PUBLIC WORKS AUTHORI	Revenue Fund	VO807655	55.05	ACCT#185 BIG CABIN TOLL	BPATTERS	RRV00349242	7/3/2024	135.75
		VO807656	80.70	ACCT#373 WR MAINLINE	BPATTERS			
		Check RRV00349242:	135.75					
<b>Total for BIG CABIN PUBLIC WORKS AUTHORITY:</b>			<b>135.75</b>					
BILL KNIGHT COLLISION REPAIR -STIL	Revenue Fund	VO807766	7,315.40	VEHICLE PARTS & REPAIR	SALLEN	RRV00349315	7/5/2024	7,315.40
		Check RRV00349315:	7,315.40					
<b>Total for BILL KNIGHT COLLISION REPAIR -STILLWATER:</b>			<b>7,315.40</b>					
BISHOP'S CORNER AUTO SALES, INC.	Revenue Fund	VO807931	47.50	FEE/ISSUANCE 19 PIKEPASS 06/2024	APERINGO	RRV00349360	7/8/2024	47.50
		Check RRV00349360:	47.50					
<b>Total for BISHOP'S CORNER AUTO SALES, INC.:</b>			<b>47.50</b>					
BIXBY RADIATOR, INC.	Revenue Fund	VO808118	200.00	EQUIPMENT REPAIRS	JJENKINS	RRV00349511	7/10/2024	200.00
		Check RRV00349511:	200.00					
<b>Total for BIXBY RADIATOR, INC.:</b>			<b>200.00</b>					
BIXBY SOUTH TAG AGENCY LLC - 728	Revenue Fund	VO807935	302.50	FEE/ISSUANCE 121 PIKEPASS 06/2024	APERINGO	RRV00349362	7/8/2024	302.50
		Check RRV00349362:	302.50					
<b>Total for BIXBY SOUTH TAG AGENCY LLC - 7283:</b>			<b>302.50</b>					
BIXBY TAG AGENCY #7267	Revenue Fund	VO807936	387.50	FEE/ISSUANCE 155 PIKEPASS 06/2024	APERINGO	RRV00349361	7/8/2024	387.50
		Check RRV00349361:	387.50					
<b>Total for BIXBY TAG AGENCY #7267:</b>			<b>387.50</b>					
BLADES MOTORS AND TIRE SERVICE	Revenue Fund	VO809944	18.50	EQUIPMENT PARTS & REPAIRS	BWESTER	RRV00350063	7/29/2024	37.00

Vendor Name	Fund Desc	Voucher NO.	Amt Applied	Description	Approver	Check No.	Date Paid	Amt Check
		VO809946	18.50	EQUIPMENT PARTS & REPAIR	BWESTER			
		Check RRV00350063:	37.00					
		<b>Total for BLADES MOTORS AND TIRE SERVICE CENTER:</b>	<b>37.00</b>					
BLAIR TAG AGENCY	Revenue Fund	VO807939	57.50	FEE/ISSUANCE 23 PIKEPASS 06/2024	APERINGO	RRV00349363	7/8/2024	57.50
		Check RRV00349363:	57.50					
		<b>Total for BLAIR TAG AGENCY:</b>	<b>57.50</b>					
BLAKELY, JAMES E., JR.	Revenue Fund	VO809349	549.16	JULY 2024 EXPENSES	NTAGGART	RRV00349910	7/23/2024	549.16
		Check RRV00349910:	549.16					
		<b>Total for BLAKELY, JAMES E., JR.:</b>	<b>549.16</b>					
BNSF RAILWAY COMPANY	General	VO809032	12,905.10	C-MC-30: RR INSPCTN SVC: 90270648	JGARDER	GEN00021496	7/18/2024	12,905.10
		Check GEN00021496:	12,905.10					
BNSF RAILWAY COMPANY	Reserve Maintenance	VO809332	19,859.97	C-MC-34, RR CNSTCTN INSP ENG; 90270554	TJD4JECH	RMT00006050	7/23/2024	19,859.97
		Check RMT00006050:	19,859.97					
		<b>Total for BNSF RAILWAY COMPANY:</b>	<b>32,765.07</b>					
BOB MOORE BUICK GMC	Revenue Fund	VO807940	25.00	FEE/ISSUANCE 10 PIKEPASS 06/2024	APERINGO	RRV00349364	7/8/2024	25.00
		Check RRV00349364:	25.00					
		<b>Total for BOB MOORE BUICK GMC:</b>	<b>25.00</b>					
BOWDEN TERMITE & PEST CONTROL	Revenue Fund	VO808850	95.00	PEST CONTROL SERVICES	BCANTREL	RRV00349766	7/17/2024	95.00
		Check RRV00349766:	95.00					
		<b>Total for BOWDEN TERMITE &amp; PEST CONTROL LLC- 2024:</b>	<b>95.00</b>					
BOXHUB INC	Revenue Fund	VO808851	2,865.00	OTHER MAINTENANCE SUPPLIES	MCOLLINS	RRV00349767	7/17/2024	2,865.00
		Check RRV00349767:	2,865.00					
		<b>Total for BOXHUB INC:</b>	<b>2,865.00</b>					
BRANDT'S ACE HARDWARE - CHK	Revenue Fund	VO807538	4.95	VEHICLE PARTS & SUPPLIES	KWALLIS	RRV00349248	7/3/2024	421.76
		VO807540	160.55	BUILDING MAINTENANCE SUPPLIES	KWALLIS			
		VO807539	57.33	EQUIPMENT PARTS & SUPPLIES	KWALLIS			
		VO807541	198.93	BUILDING MAINTENANCE SUPPLIES	KWALLIS			
		Check RRV00349248:	421.76					
BRANDT'S ACE HARDWARE - CHK	Revenue Fund	VO808853	61.56	SMALL TOOL, PARTS & OTHER MAINT SUPPLIES	KWALLIS	RRV00349768	7/17/2024	61.56
		Check RRV00349768:	61.56					
BRANDT'S ACE HARDWARE - CHK	Revenue Fund	VO809431	12.99	HARDWARE	KWALLIS	RRV00349950	7/24/2024	132.97
		VO809438	119.98	EQUIPMENT PARTS & SUPPLIES	KWALLIS			
		Check RRV00349950:	132.97					
		<b>Total for BRANDT'S ACE HARDWARE - CHK:</b>	<b>616.29</b>					
BRISTOW TAG AGENCY - ANGELA M	Revenue Fund	VO807942	70.00	FEE/ISSUANCE 28 PIKEPASS 06/2024	APERINGO	RRV00349365	7/8/2024	70.00
		Check RRV00349365:	70.00					
		<b>Total for BRISTOW TAG AGENCY - ANGELA MARLOW #1920:</b>	<b>70.00</b>					
BRISTOW TIRE & AUTO SERVICE, INC	Revenue Fund	VO807616	15.00	EQUIPMENT REPAIRS	RDTAYLOR	RRV00349249	7/3/2024	15.00
		Check RRV00349249:	15.00					
BRISTOW TIRE & AUTO SERVICE, INC	Revenue Fund	VO808119	999.80	VEHICLE PARTS & REPAIRS	JSMART	RRV00349510	7/10/2024	999.80
		Check RRV00349510:	999.80					

Vendor Name	Fund Desc	Voucher NO.	Amt Applied	Description	Approver	Check No.	Date Paid	Amt Check
BRISTOW TIRE & AUTO SERVICE, INC	Revenue Fund	VO808854	15.00	EQUIPMENT REPAIR	RDTAYLOR	RRV00349770	7/17/2024	116.90
		VO808858	101.90	EQUIPMENT PARTS & REPAIR	RDTAYLOR			
		Check RRV00349770:	116.90					
<b>Total for BRISTOW TIRE &amp; AUTO SERVICE, INC:</b>			<b>1,514.50</b>					
BROADWAY TAG AGENCY	Revenue Fund	VO807943	305.00	FEE/ISSUANCE 122 PIKEPASS 06/2024	APERINGO	RRV00349366	7/8/2024	305.00
		Check RRV00349366:	305.00					
		<b>Total for BROADWAY TAG AGENCY:</b>		<b>305.00</b>				
BROKEN ARROW TITLE, INC	Revenue Fund	VO808679	21,300.00	BLDNG MAINT SVCS ; #10100	TJDILL	REV00016067	7/23/2024	21,300.00
		Check REV00016067:	21,300.00					
		<b>Total for BROKEN ARROW TITLE, INC:</b>		<b>21,300.00</b>				
BROWN'S TAG AGENCY	Revenue Fund	VO807944	130.00	FEE/ISSUANCE 52 PIKEPASS 06/2024	APERINGO	RRV00349367	7/8/2024	130.00
		Check RRV00349367:	130.00					
		<b>Total for BROWN'S TAG AGENCY:</b>		<b>130.00</b>				
BRUCKNER TRUCK & EQUIPMENT	Revenue Fund	VO808861	105.72	EQUIPMENT PARTS & SUPPLIES	DCRAIG	RRV00349771	7/17/2024	105.72
		Check RRV00349771:	105.72					
		<b>Total for BRUCKNER TRUCK &amp; EQUIPMENT:</b>		<b>105.72</b>				
BRYAN COUNTY TAG AGENCY	Revenue Fund	VO807945	47.50	FEE/ISSUANCE 19 PIKEPASS 06/2024	APERINGO	RRV00349368	7/8/2024	47.50
		Check RRV00349368:	47.50					
		<b>Total for BRYAN COUNTY TAG AGENCY:</b>		<b>47.50</b>				
BUICK, GMC, KDG AUTOMOTIVE	Revenue Fund	VO808192	85.00	FEE/ISSUANCE 34 PIKEPASS 06/2024	APERINGO	RRV00349495	7/10/2024	85.00
		Check RRV00349495:	85.00					
		<b>Total for BUICK, GMC, KDG AUTOMOTIVE:</b>		<b>85.00</b>				
BUILT RIGHT CONSTRUCTION, LLC	General	VO808708	2,135,763.41	IN-MC-66: ESTIMATE NO. 6	TJD4JECH	GEN00021477	7/15/2024	2,135,763.41
		Check GEN00021477:	2,135,763.41					
		<b>Total for BUILT RIGHT CONSTRUCTION, LLC:</b>		<b>2,135,763.41</b>				
BUILT RIGHT CONSTRUCTION, LLC	Reserve Maintenance	VO807659	6,462.00	T-ER-041 ; ESTIMATE NO. 2	TJDILL	RMT00006042	7/3/2024	6,462.00
		Check RMT00006042:	6,462.00					
		<b>Total for BUILT RIGHT CONSTRUCTION, LLC:</b>		<b>6,462.00</b>				
BURNETTS TRUE VALUE HARDWARE	Revenue Fund	VO808870	29.99	EQUIPMENT PARTS & SUPPLIES	BELLIS	RRV00349769	7/17/2024	29.99
		Check RRV00349769:	29.99					
		<b>Total for BURNETTS TRUE VALUE HARDWARE, INC.:</b>		<b>29.99</b>				
BURRELL, LOWELL	Revenue Fund	VO808819	10.00	JULY 2024 EXPENSES	PGOGGIN	RRV00349746	7/16/2024	10.00
		Check RRV00349746:	10.00					
		<b>Total for BURRELL, LOWELL:</b>		<b>10.00</b>				
C H GUERNSEY & COMPANY	General	VO807695	129,750.00	SP-71A/71D: ENG RPT/PRE PLNS: 143696	TJDILL	GEN00021447	7/3/2024	129,750.00
		Check GEN00021447:	129,750.00					
		<b>Total for C H GUERNSEY &amp; COMPANY:</b>		<b>129,750.00</b>				

Vendor Name	Fund Desc	Voucher NO.	Amt Applied	Description	Approver	Check No.	Date Paid	Amt Check
CAESAR, PAUL	Revenue Fund	VO808049	<u>102.99</u>	JULY 2024 EXPENSES	TJDILL	RRV00349388	7/9/2024	102.99
		Check RRV00349388:	<u>102.99</u>					
		<b>Total for CAESAR, PAUL:</b>	<b>102.99</b>					
CALFY BROTHERS BUILDING CENTER	Revenue Fund	VO808122	<u>29.43</u>	EQUIPMENT PARTS & OTHER SUPPLIES	K WALLIS	RRV00349513	7/10/2024	68.84
		VO808124	<u>39.41</u>	ASPHALT & CONCRETE SUPPLIES				
		Check RRV00349513:	<u>68.84</u>					
<b>Total for CALFY BROTHERS BUILDING CENTER:</b>		<b>68.84</b>						
CALVERT'S PLANT INTERIORS	Revenue Fund	VO807618	<u>409.12</u>	OTHER MAINTENANCE	JECHELLE	RRV00349250	7/3/2024	409.12
		Check RRV00349250:	<u>409.12</u>					
CALVERT'S PLANT INTERIORS	Revenue Fund	VO809962	<u>409.12</u>	OTHER MAINTENANCE	TGOORE	RRV00350110	7/31/2024	409.12
		Check RRV00350110:	<u>409.12</u>					
		<b>Total for CALVERT'S PLANT INTERIORS:</b>	<b>818.24</b>					
CANADIAN VALLEY ELECTRIC COOP	Revenue Fund	VO807438	<u>1,815.74</u>	ELECTRIC	BPATTERS	EFT018731	7/1/2024	1,815.74
		Check EFT018731:	<u>1,815.74</u>					
		<b>Total for CANADIAN VALLEY ELECTRIC COOP:</b>	<b>1,815.74</b>					
CANTRELL, BRYAN	Revenue Fund	VO807621	<u>155.19</u>	JULY 2024 EXPENSES	M COLLINS	RRV00349228	7/2/2024	155.19
		Check RRV00349228:	<u>155.19</u>					
CANTRELL, BRYAN	Revenue Fund	VO809350	<u>39.80</u>	JULY 2024 EXPENSES	M COLLINS	RRV00349911	7/23/2024	39.80
		Check RRV00349911:	<u>39.80</u>					
		<b>Total for CANTRELL, BRYAN:</b>	<b>194.99</b>					
CAPITOL HILL TAG AGENCY	Revenue Fund	VO808020	<u>37.50</u>	FEE/ISSUANCE 15 PIKEPASS 06/2024	APERINGO	RRV00349415	7/9/2024	37.50
		Check RRV00349415:	<u>37.50</u>					
		<b>Total for CAPITOL HILL TAG AGENCY:</b>	<b>37.50</b>					
CARDIO PARTNERS INC	Revenue Fund	VO808871	<u>1,993.00</u>	SAFETY & MEDICAL SUPPLIES	S ALLEN	RRV00349773	7/17/2024	3,986.00
		VO808872	<u>1,993.00</u>	SAFETY & MEDICAL SUPPLIES				
		Check RRV00349773:	<u>3,986.00</u>					
<b>Total for CARDIO PARTNERS INC:</b>		<b>3,986.00</b>						
CARDMEMBER SERVICE	Revenue Fund	VO807612	<u>25,327.21</u>	VISA CHRGS ; 05/16/2024 - 06/14/2024	JECHELLE	REV00016024	7/2/2024	25,327.21
		Check REV00016024:	<u>25,327.21</u>					
		<b>Total for CARDMEMBER SERVICE:</b>	<b>25,327.21</b>					
CARDS NEO, LLC	Revenue Fund	VO807535	<u>1,009.64</u>	SOLID WASTE/TRASH DISPOSAL	M COLLINS	RRV00349164	7/1/2024	1,009.64
		Check RRV00349164:	<u>1,009.64</u>					
CARDS NEO, LLC	Revenue Fund	VO808126	<u>150.00</u>	EQUIPMENT RENTAL	BCANTREL	RRV00349514	7/10/2024	150.00
		Check RRV00349514:	<u>150.00</u>					
CARDS NEO, LLC	Revenue Fund	VO808873	<u>1,183.15</u>	SOLID WASTE/TRASH DISPOSAL	M COLLINS	RRV00349772	7/17/2024	1,183.15
		Check RRV00349772:	<u>1,183.15</u>					
CARDS NEO, LLC	Revenue Fund	VO809964	<u>1,019.74</u>	SOLID WASTE/TRASH DISPOSAL	M COLLINS	RRV00350111	7/31/2024	1,019.74
		Check RRV00350111:	<u>1,019.74</u>					
		<b>Total for CARDS NEO, LLC:</b>	<b>3,362.53</b>					

Vendor Name	Fund Desc	Voucher NO.	Amt Applied	Description	Approver	Check No.	Date Paid	Amt Check
CARTERS FOOD CENTER OF VINITA II	Revenue Fund	VO808874	165.22	EMPLOYEE INCENTIVE AWARDS - FOOD, CATER	DCRAIG	RRV00349774	7/17/2024	165.22
		Check RRV00349774:	165.22					
<b>Total for CARTERS FOOD CENTER OF VINITA INC:</b>			<b>165.22</b>					
CDM SMITH INC.	General	VO809266	15,797.00	OTA RTNR 6/1/24 - 6/30/2024: 90210584	WSMITH	GEN00021504	7/19/2024	15,797.00
		Check GEN00021504:	15,797.00					
CDM SMITH INC.	General	VO810001	52,661.92	TO-01-2024: GTC CNTRCT SPPRT: 90210802	TJDILL	GEN00021537	7/29/2024	52,661.92
		Check GEN00021537:	52,661.92					
<b>Total for CDM SMITH INC.:</b>			<b>68,458.92</b>					
CDW GOVERNMENT LLC, CDW GOV	Revenue Fund	VO809268	62,858.72	ANNUAL SFTWR RENEW/SUB ; RW56865	ABOULDEN	REV00016061	7/22/2024	62,858.72
		Check REV00016061:	62,858.72					
<b>Total for CDW GOVERNMENT LLC, CDW GOVERNMENT:</b>			<b>62,858.72</b>					
CEC CORPORATION	Capital Projects	VO809682	43,325.94	T-MC-128C: CON INSPCTN/TST: 07n000230836	TJDILL	23A0000243	7/26/2024	107,195.94
		VO809683	63,870.00	JKT-30603A: DSGN SVCS: 3JKT000240109	TJDILL			
		Check 23A0000243:	107,195.94					
CEC CORPORATION	General	VO808936	16,548.26	IN-MC-67: SR ENG/AUD/TEST: 14n000230367	JGARDER	GEN00021487	7/17/2024	16,548.26
		Check GEN00021487:	16,548.26					
<b>Total for CEC CORPORATION:</b>			<b>123,744.20</b>					
CENTRAL DISPOSAL, LLC	Revenue Fund	VO808876	400.00	SOLID WASTE/TRASH DISPOSAL	RDTAYLOR	RRV00349775	7/17/2024	400.00
		Check RRV00349775:	400.00					
<b>Total for CENTRAL DISPOSAL, LLC:</b>			<b>400.00</b>					
CENTRAL OKLAHOMA STORMWATER	Revenue Fund	VO808913	600.00	PROFESSIONAL ORGANIZATION MEMBERSHIPS	DBUTLER	RRV00349814	7/17/2024	600.00
		Check RRV00349814:	600.00					
<b>Total for CENTRAL OKLAHOMA STORMWATER ALLIANCE, INC:</b>			<b>600.00</b>					
CENTRAL PARK TAG AGENCY	Revenue Fund	VO808021	602.50	FEE/ISSUANCE 241 PIKEPASS 06/2024	APERINGO	RRV00349752	7/16/2024	602.50
		Check RRV00349752:	602.50					
<b>Total for CENTRAL PARK TAG AGENCY:</b>			<b>602.50</b>					
CENTRAL RURAL ELECTRIC COOP	Revenue Fund	VO807727	2,499.55	ELECTRIC	BPATTERS	EFT018764	7/5/2024	2,499.55
		Check EFT018764:	2,499.55					
<b>Total for CENTRAL RURAL ELECTRIC COOP:</b>			<b>2,499.55</b>					
CENTRAL SALT LLC	Revenue Fund	VO808683	2,567.52	ICE & SNOW CNTRL SUPPLIES; PSI24-09712	JE4TGATZ	REV00016038	7/15/2024	18,795.46
		VO808684	11,670.80	ICE & SNOW CNTRL SUPPLIES; PSI24-09441	JE4TGATZ			
		VO808681	4,557.14	ICE & SNOW CNTRL SUPPLIES; PSI24-09486	JE4TGATZ			
		Check REV00016038:	18,795.46					
CENTRAL SALT LLC	Revenue Fund	VO810047	4,641.66	ICE & SNOW CONTROL SUPPLIES	SALLEN	RRV00350112	7/31/2024	9,214.28
		VO810050	4,572.62	ICE & SNOW CONTROL SUPPLIES	SALLEN			
		Check RRV00350112:	9,214.28					
<b>Total for CENTRAL SALT LLC:</b>			<b>28,009.74</b>					
CENTRAL TAG AGENCY	Revenue Fund	VO808022	390.00	FEE/ISSUANCE 156 PIKEPASS 06/2024	APERINGO	RRV00349430	7/9/2024	390.00
		Check RRV00349430:	390.00					
<b>Total for CENTRAL TAG AGENCY:</b>			<b>390.00</b>					
CHAMPION CLEANING SERVICE, INC.	Revenue Fund	VO807619	950.00	CUSTODIAL SERVICES	PGOGGIN	RRV00349252	7/3/2024	950.00



Vendor Name	Fund Desc	Voucher NO.	Amt Applied	Description	Approver	Check No.	Date Paid	Amt Check
		Check RRV00349252:	950.00					
		<b>Total for CHAMPION CLEANING SERVICE, INC.:</b>	<b>950.00</b>					
CHANDLER HARDWARE	Revenue Fund	VO807620	80.84	CLEANING SUPPLIES & SMALL TOOLS	RDTAYLOR	RRV00349253	7/3/2024	80.84
		Check RRV00349253:	80.84					
		<b>Total for CHANDLER HARDWARE:</b>	<b>80.84</b>					
CHANDLER MUNICIPAL AUTHORITY	Revenue Fund	VO807596	15.44	WATER SERVICE	BPATTERS	EFT018746	7/2/2024	15.44
		Check EFT018746:	15.44					
		<b>Total for CHANDLER MUNICIPAL AUTHORITY:</b>	<b>15.44</b>					
CHANDLER TIRE CENTER	Revenue Fund	VO809448	14.00	EQUIPMENT REPAIR	RDTAYLOR	RRV00349952	7/24/2024	14.00
		Check RRV00349952:	14.00					
		<b>Total for CHANDLER TIRE CENTER:</b>	<b>14.00</b>					
CHARLEYS SOUTHSIDE LOCKSMITH S	Revenue Fund	VO807631	6.00	OTHER COMMODITIES & SUPPLIES	JMELTON	RRV00349251	7/3/2024	6.00
		Check RRV00349251:	6.00					
		<b>Total for CHARLEYS SOUTHSIDE LOCKSMITH SERVICE:</b>	<b>6.00</b>					
CHECOTAH TAG AGENCY LLC	Revenue Fund	VO808023	45.00	FEE/ISSUANCE 18 PIKEPASS 06/2024	APERINGO	RRV00349424	7/9/2024	45.00
		Check RRV00349424:	45.00					
		<b>Total for CHECOTAH TAG AGENCY LLC:</b>	<b>45.00</b>					
CHEROKEE COUNTY TAG AGENCY	Revenue Fund	VO808024	160.00	FEE/ISSUANCE 64 PIKEPASS 06/2024	APERINGO	RRV00349416	7/9/2024	160.00
		Check RRV00349416:	160.00					
		<b>Total for CHEROKEE COUNTY TAG AGENCY:</b>	<b>160.00</b>					
CHICKASAW TELECOMMUNICATION	Revenue Fund	VO808127	1,300.00	EQUIPMENT RENTAL	ABOULDEN	RRV00349516	7/10/2024	1,300.00
		Check RRV00349516:	1,300.00					
		<b>Total for CHICKASAW TELECOMMUNICATIONS SVCS, INC:</b>	<b>1,300.00</b>					
CHICKASAW TELEPHONE COMPANY	Revenue Fund	VO807909	75.36	PHONE SERVICE	JLYTLE	EFT018771	7/8/2024	75.36
		Check EFT018771:	75.36					
		<b>Total for CHICKASAW TELEPHONE COMPANY:</b>	<b>75.36</b>					
CHICKASHA INDSTR & WLDNG SUPI	Revenue Fund	VO807634	4.00	VEHICLE PARTS & SUPPLIES	KWALLIS	RRV00349254	7/3/2024	4.00
		Check RRV00349254:	4.00					
CHICKASHA INDSTR & WLDNG SUPI	Revenue Fund	VO808877	979.64	EQUIP PARTS, OTHER MAINT SUPPLIES & SRVC	KWALLIS	RRV00349776	7/17/2024	979.64
		Check RRV00349776:	979.64					
		<b>Total for CHICKASHA INDSTR &amp; WLDNG SUPP, INC:</b>	<b>983.64</b>					
CHICKASHA LUMBER COMPANY	Revenue Fund	VO807635	10.10	ASPHALT & CONCRETE SUPPLIES	KWALLIS	RRV00349255	7/3/2024	10.10
		Check RRV00349255:	10.10					
CHICKASHA LUMBER COMPANY	Revenue Fund	VO808132	15.15	ASPHALT & CONCRETE SUPPLIES	KWALLIS	RRV00349515	7/10/2024	15.15
		Check RRV00349515:	15.15					
		<b>Total for CHICKASHA LUMBER COMPANY:</b>	<b>25.25</b>					
CHICKASHA TAG AGENCY - 2619	Revenue Fund	VO808025	370.00	FEE/ISSUANCE 148 PIKEPASS 06/2024	APERINGO	RRV00349417	7/9/2024	370.00
		Check RRV00349417:	370.00					
		<b>Total for CHICKASHA TAG AGENCY - 2619:</b>	<b>370.00</b>					
CHOCTAW ELECTRIC COOP., INC	Revenue Fund	VO809547	1,408.21	ELECTRIC	BPATTERS	EFT018815	7/25/2024	1,408.21

Vendor Name	Fund Desc	Voucher NO.	Amt Applied	Description	Approver	Check No.	Date Paid	Amt Check
		Check EFT018815:	1,408.21					
		<b>Total for CHOCTAW ELECTRIC COOP., INC:</b>	<b>1,408.21</b>					
CHOCTAW SOUTH TAG AGENCY - 88	Revenue Fund	VO808027	72.50	FEE/ISSUANCE 29 PIKEPASS 06/2024	APERINGO	RRV00349418	7/9/2024	72.50
		Check RRV00349418:	72.50					
		<b>Total for CHOCTAW SOUTH TAG AGENCY - 8825:</b>	<b>72.50</b>					
CHOCTAW TAG AGENCY	Revenue Fund	VO808028	77.50	FEE/ISSUANCE 31 PIKEPASS 06/2024	APERINGO	RRV00349419	7/9/2024	77.50
		Check RRV00349419:	77.50					
		<b>Total for CHOCTAW TAG AGENCY:</b>	<b>77.50</b>					
CHRISTIAN BROTHERS AUTO-WARW	Revenue Fund	VO808035	12.50	FEE/ISSUANCE 5 PIKEPASS 06/2024	APERINGO	RRV00349421	7/9/2024	12.50
		Check RRV00349421:	12.50					
		<b>Total for CHRISTIAN BROTHERS AUTO-WARWICK - OKC:</b>	<b>12.50</b>					
CHRISTIAN BROTHERS AUTO. - EAST	Revenue Fund	VO808031	27.50	FEE/ISSUANCE 11 PIKEPASS 06/2024	APERINGO	RRV00349422	7/9/2024	27.50
		Check RRV00349422:	27.50					
		<b>Total for CHRISTIAN BROTHERS AUTO. - EAST EDMOND:</b>	<b>27.50</b>					
CHRISTIAN BROTHERS AUTOMOTIVE	Revenue Fund	VO808037	20.00	FEE/ISSUANCE 8 PIKEPASS 06/2024	APERINGO	RRV00349750	7/16/2024	20.00
		Check RRV00349750:	20.00					
		<b>Total for CHRISTIAN BROTHERS AUTOMOTIVE - YUKON:</b>	<b>20.00</b>					
CHRISTIAN BROTHERS AUTOMOTIVE	Revenue Fund	VO808034	50.00	FEE/ISSUANCE 20 PIKEPASS 06/2024	APERINGO	RRV00349423	7/9/2024	50.00
		Check RRV00349423:	50.00					
		<b>Total for CHRISTIAN BROTHERS AUTOMOTIVE OWASSO:</b>	<b>50.00</b>					
CINTAS CORPORATION #618	Revenue Fund	VO807642	132.08	LAUNDRY SERVICES	BWESTER	RRV00349259	7/3/2024	132.08
		Check RRV00349259:	132.08					
CINTAS CORPORATION #618	Revenue Fund	VO808887	132.08	LAUNDRY SERVICES	BELLIS	RRV00349780	7/17/2024	264.16
		VO808896	132.08	LAUNDRY SERVICES	BELLIS			
		Check RRV00349780:	264.16					
CINTAS CORPORATION #618	Revenue Fund	VO809489	132.08	LAUNDRY SERVICES	BWESTER	RRV00349955	7/24/2024	132.08
		Check RRV00349955:	132.08					
CINTAS CORPORATION #618	Revenue Fund	VO809993	132.08	LAUNDRY SERVICES	BWESTER	RRV00350116	7/31/2024	132.08
		Check RRV00350116:	132.08					
		<b>Total for CINTAS CORPORATION #618:</b>	<b>660.40</b>					
CINTAS CORPORATION - 063	Revenue Fund	VO807637	256.02	LAUNDRY SERVICES	DCRAIG	RRV00349257	7/3/2024	703.67
		VO807639	447.65	LAUNDRY SERVICES	RDTAYLOR			
		Check RRV00349257:	703.67					
CINTAS CORPORATION - 063	Revenue Fund	VO808135	667.09	LAUNDRY SERVICES	BCANTREL	RRV00349518	7/10/2024	667.09
		Check RRV00349518:	667.09					
CINTAS CORPORATION - 063	Revenue Fund	VO808889	282.01	LAUNDRY SERVICES	DCRAIG	RRV00349778	7/17/2024	282.01
		Check RRV00349778:	282.01					
CINTAS CORPORATION - 063	Revenue Fund	VO809451	555.34	LAUNDRY SERVICES	RDTAYLOR	RRV00349954	7/24/2024	1,186.15
		VO809457	75.47	LAUNDRY SERVICES	JSMITH			
		VO809454	555.34	LAUNDRY SERVICES	RDTAYLOR			

Vendor Name	Fund Desc	Voucher NO.	Amt Applied	Description	Approver	Check No.	Date Paid	Amt Check
		Check RRV00349954:	1,186.15					
CINTAS CORPORATION - 063	Revenue Fund	VO809991	256.02	LAUNDRY SERVICES	DCRAIG	RRV00350114	7/31/2024	256.02
		Check RRV00350114:	256.02					
		<b>Total for CINTAS CORPORATION - 063:</b>	<b>3,094.94</b>					
CINTAS CORPORATION 064	Revenue Fund	VO807643	87.61	LAUNDRY SERVICES	KWALLIS	RRV00349256	7/3/2024	87.61
		Check RRV00349256:	87.61					
CINTAS CORPORATION 064	Revenue Fund	VO808134	87.61	LAUNDRY SERVICES	KWALLIS	RRV00349517	7/10/2024	87.61
		Check RRV00349517:	87.61					
CINTAS CORPORATION 064	Revenue Fund	VO808893	87.61	LAUNDRY SERVICES	KWALLIS	RRV00349777	7/17/2024	87.61
		Check RRV00349777:	87.61					
CINTAS CORPORATION 064	Revenue Fund	VO809491	87.61	LAUNDRY SERVICES	KWALLIS	RRV00349953	7/24/2024	87.61
		Check RRV00349953:	87.61					
CINTAS CORPORATION 064	Revenue Fund	VO809995	87.61	LAUNDRY SERVICES	KWALLIS	RRV00350113	7/31/2024	87.61
		Check RRV00350113:	87.61					
		<b>Total for CINTAS CORPORATION 064:</b>	<b>438.05</b>					
CINTAS FIRST AID & SAFETY	Revenue Fund	VO807640	85.85	SAFETY & MEDICAL SUPPLIES	JJENKINS	RRV00349258	7/3/2024	85.85
		Check RRV00349258:	85.85					
CINTAS FIRST AID & SAFETY	Revenue Fund	VO808133	80.72	SAFETY & MEDICAL SUPPLIES	DCRAIG	RRV00349519	7/10/2024	80.72
		Check RRV00349519:	80.72					
CINTAS FIRST AID & SAFETY	Revenue Fund	VO808885	89.65	SAFETY & MEDICAL SUPPLIES	JJENKINS	RRV00349779	7/17/2024	293.26
		VO808897	82.70	SAFETY & MEDICAL SUPPLIES	BCANTREL			
		VO808882	120.91	SAFETY & MEDICAL SUPPLIES	AHEITZ			
		Check RRV00349779:	293.26					
CINTAS FIRST AID & SAFETY	Revenue Fund	VO809990	59.40	SAFETY & MEDICAL SUPPLIES	JJENKINS	RRV00350115	7/31/2024	123.66
		VO809994	64.26	SAFETY & MEDICAL SUPPLIES	KWALLIS			
		Check RRV00350115:	123.66					
		<b>Total for CINTAS FIRST AID &amp; SAFETY:</b>	<b>583.49</b>					
CITY GLASS COMPANY OF STILLWATER, INC:	Revenue Fund	VO808136	280.75	EQUIPMENT PARTS & REPAIR	RROWEN	RRV00349521	7/10/2024	280.75
		Check RRV00349521:	280.75					
		<b>Total for CITY GLASS COMPANY OF STILLWATER, INC:</b>	<b>280.75</b>					
CITY OF BRISTOW	Revenue Fund	VO807591	124.16	WATER SERVICE	BPATTERS	EFT018747	7/2/2024	124.16
		Check EFT018747:	124.16					
CITY OF BRISTOW	Revenue Fund	VO809494	1,150.00	PUBLIC SAFETY SERVICES - FIRE CALLS	JSMITH	RRV00349957	7/24/2024	1,150.00
		Check RRV00349957:	1,150.00					
		<b>Total for CITY OF BRISTOW:</b>	<b>1,274.16</b>					
CITY OF BROKEN ARROW	Revenue Fund	VO807483	37.54	WATER	BPATTERS	EFT018740	7/1/2024	37.54
		Check EFT018740:	37.54					
		<b>Total for CITY OF BROKEN ARROW:</b>	<b>37.54</b>					
CITY OF CLAREMORE	Revenue Fund	VO807479	248.34	WATER SERVICE	BPATTERS	EFT018741	7/1/2024	248.34

Vendor Name	Fund Desc	Voucher NO.	Amt Applied	Description	Approver	Check No.	Date Paid	Amt Check
		Check EFT018741:	248.34					
		<b>Total for CITY OF CLAREMORE:</b>	<b>248.34</b>					
CITY OF JENKS	Reserve Maintenance	VO808658	19,437.00	REFUND OVERCHARGE,SURPLUS SALE;7022024	JECHELLE	RMT00006046	7/15/2024	19,437.00
		Check RMT00006046:	19,437.00					
		<b>Total for CITY OF JENKS:</b>	<b>19,437.00</b>					
CITY OF OKLAHOMA CITY	Revenue Fund	VO807726	1,805.99	WATER	BPATTERS	EFT018765	7/5/2024	1,805.99
		Check EFT018765:	1,805.99					
CITY OF OKLAHOMA CITY	Revenue Fund	VO808812	1,532.28	WATER SERVICE	BPATTERS	EFT018806	7/16/2024	1,532.28
		Check EFT018806:	1,532.28					
		<b>Total for CITY OF OKLAHOMA CITY:</b>	<b>3,338.27</b>					
CITY OF STROUD	Revenue Fund	VO807710	2,400.65	WATER	BPATTERS	EFT018757	7/5/2024	2,400.65
		Check EFT018757:	2,400.65					
		<b>Total for CITY OF STROUD:</b>	<b>2,400.65</b>					
CITY OF TULSA	Revenue Fund	VO807724	93.65	WATER	BPATTERS	EFT018766	7/5/2024	93.65
		Check EFT018766:	93.65					
CITY OF TULSA	Revenue Fund	VO808013	141.73	WATER	BPATTERS	EFT018775	7/9/2024	141.73
		Check EFT018775:	141.73					
CITY OF TULSA	Revenue Fund	VO807435	148.34	ACCT#255955-2204665 WATER HYDRANT	BPATTERS	RRV00349161	7/1/2024	148.34
		Check RRV00349161:	148.34					
		<b>Total for CITY OF TULSA:</b>	<b>383.72</b>					
CITY OF WALTERS	Revenue Fund	VO807598	127.54	WATER	BPATTERS	EFT018748	7/2/2024	127.54
		Check EFT018748:	127.54					
		<b>Total for CITY OF WALTERS:</b>	<b>127.54</b>					
CKENERGY ELECTRIC COOPERATIVE,	Revenue Fund	VO807480	697.00	ELECTRIC	BPATTERS	EFT018738	7/1/2024	697.00
		Check EFT018738:	697.00					
		<b>Total for CKENERGY ELECTRIC COOPERATIVE, INC.:</b>	<b>697.00</b>					
CLAREMORE TAG AGENCY AT SERV	Revenue Fund	VO808038	162.50	FEE/ISSUANCE 65 PIKEPASS 06/2024	APERINGO	RRV00349751	7/16/2024	162.50
		Check RRV00349751:	162.50					
		<b>Total for CLAREMORE TAG AGENCY AT SERVICE OKLAHOMA:</b>	<b>162.50</b>					
CLASSEN TAG AGENCY	Revenue Fund	VO808041	217.50	FEE/ISSUANCE 87 PIKEPASS 06/2024	APERINGO	RRV00349425	7/9/2024	217.50
		Check RRV00349425:	217.50					
		<b>Total for CLASSEN TAG AGENCY:</b>	<b>217.50</b>					
CLEARVIEW	Revenue Fund	VO807678	80.00	OTHER CONTRACTUAL SERVICES	BWESTER	RRV00349261	7/3/2024	80.00
		Check RRV00349261:	80.00					
CLEARVIEW	Revenue Fund	VO809996	80.00	OTHER CONTRACTUAL SERVICES	BWESTER	RRV00350117	7/31/2024	80.00
		Check RRV00350117:	80.00					
		<b>Total for CLEARVIEW:</b>	<b>160.00</b>					
CLEVELAND TAG AGENCY - 5911	Revenue Fund	VO808046	52.50	FEE/ISSUANCE 21 PIKEPASS 06/2024	APERINGO	RRV00349427	7/9/2024	52.50
		Check RRV00349427:	52.50					
		<b>Total for CLEVELAND TAG AGENCY - 5911:</b>	<b>52.50</b>					

Vendor Name	Fund Desc	Voucher NO.	Amt Applied	Description	Approver	Check No.	Date Paid	Amt Check	
CLIFTON ASHFORD & ASSOCIATES, LI	Capital Projects	VO808837	41,983.28	T-MC-131: BEAM INSPCTN: INV# 3-1057	TJDILL	23A0000228	7/16/2024	41,983.28	
		Check 23A0000228:	41,983.28						
		<b>Total for CLIFTON ASHFORD &amp; ASSOCIATES, LLC:</b>	<b>41,983.28</b>						
CLINTON TAG AGENCY	Revenue Fund	VO808051	160.00	FEE/ISSUANCE 64 PIKEPASS 06/2024	APERINGO	RRV00349428	7/9/2024	160.00	
		Check RRV00349428:	160.00						
		<b>Total for CLINTON TAG AGENCY:</b>	<b>160.00</b>						
CM ELECTRIC	Revenue Fund	VO807617	450.00	OTHER CONTRACTUAL SERVICES	CHUGHES	RRV00349260	7/3/2024	450.00	
		Check RRV00349260:	450.00						
		<b>Total for CM ELECTRIC:</b>	<b>450.00</b>						
COAL COUNTY TAG AGENCY, LLC	Revenue Fund	VO808054	7.50	FEE/ISSUANCE 3 PIKEPASS 06/2024	APERINGO	RRV00349431	7/9/2024	7.50	
		Check RRV00349431:	7.50						
		<b>Total for COAL COUNTY TAG AGENCY, LLC:</b>	<b>7.50</b>						
COATES FIELD SERVICE, INC.	General	VO808954	3,600.00	ROW SRPLS: PASS THRU: NPVAL: 85433	TGORE	GEN00021488	7/17/2024	19,469.12	
		VO808961	15,869.12	ROW ACQUSTN-SRPLS: INV# 85432	TJDILL				
		Check GEN00021488:	19,469.12						
		<b>Total for COATES FIELD SERVICE, INC.:</b>	<b>19,469.12</b>						
COLLINSVILLE TAG AGENCY	Revenue Fund	VO808057	67.50	FEE/ISSUANCE 27 PIKEPASS 06/2024	APERINGO	RRV00349432	7/9/2024	67.50	
		Check RRV00349432:	67.50						
		<b>Total for COLLINSVILLE TAG AGENCY:</b>	<b>67.50</b>						
COMANCHE COUNTY TAG AGENCY #	Revenue Fund	VO808059	447.50	FEE/ISSUANCE 179 PIKEPASS 06/2024	APERINGO	RRV00349433	7/9/2024	447.50	
		Check RRV00349433:	447.50						
		<b>Total for COMANCHE COUNTY TAG AGENCY #1627:</b>	<b>447.50</b>						
COMDATA	Revenue Fund	VO808686	80,173.29	FUEL & GAS, MAY 2024 ; 20408662	JSMITH	REV00016039	7/15/2024	80,173.29	
		Check REV00016039:	80,173.29						
COMDATA	Revenue Fund	VO809066	13,245.63	FUEL & GAS, MAY 2024 ; 20408533	BPATTERS	REV00016055	7/18/2024	46,788.30	
		VO809058	9,043.83	FUEL & GAS, JUNE 2024 ; 20409172					SALLEN
		VO809064	9,940.20	FUEL & GAS, JUNE 2024 ; 20409214					SALLEN
		VO809060	6,092.67	FUEL & GAS, JUNE 2024 ; 20409189					MCOLLINS
		VO809063	8,465.97	FUEL & GAS, JUNE 2024 ; 20409226					MCOLLINS
		Check REV00016055:	46,788.30						
COMDATA	Revenue Fund	VO809645	9,224.82	FUEL & GAS, JUNE 2024 ; 20409285	MCOLLINS	REV00016069	7/26/2024	31,550.27	
		VO809642	6,286.55	FUEL & GAS, JUNE 2024 ; 20409181					MCOLLINS
		VO809643	16,038.90	FUEL & GAS, JUNE 2024 ; 20409210					SALLEN
		Check REV00016069:	31,550.27						
COMDATA	Revenue Fund	VO805466	9,994.94	FUEL & GASOLINE	MCOLLINS	RRV00349753	7/16/2024	9,994.94	
		Check RRV00349753:	9,994.94						
COMDATA	Revenue Fund	VO809279	11,966.17	FUEL & GASOLINE	MCOLLINS	RRV00349898	7/22/2024	11,966.17	
		Check RRV00349898:	11,966.17						
COMDATA	Revenue Fund	VO809496	7,356.99	FUEL & GASOLINE	SALLEN	RRV00349956	7/24/2024	7,356.99	
		Check RRV00349956:	7,356.99						
		<b>Total for COMDATA:</b>	<b>187,829.96</b>						

Vendor Name	Fund Desc	Voucher NO.	Amt Applied	Description	Approver	Check No.	Date Paid	Amt Check
CONCENTRA MEDICAL CENTERS	Revenue Fund	VO809522	<u>306.00</u>	MEDICAL SERVICES	MCOLLINS	RRV00350016	7/26/2024	306.00
		Check RRV00350016:	<u>306.00</u>					
		<b>Total for CONCENTRA MEDICAL CENTERS:</b>	<b>306.00</b>					
CONDUENT STATE & LOCAL SOLUTIC General		VO808670	3,803.23	PLTPY MANUL IMAG RVW: GILC: 1725625-A	PWILLIAM	GEN00021492	7/17/2024	23,998.13
		VO808671	5,671.16	PLTPY MANUL IMAG RVW: GILC: 1725630-A	PWILLIAM			
		VO808674	5,460.78	PLTPY MANUL IMAG RVW: GILC: 1725715-A	PWILLIAM			
		VO808677	4,991.54	PLTPY MANUL IMAG RVW: GILC: 1725717-A	PWILLIAM			
		VO808675	<u>4,071.42</u>	PLTPY MANUL IMAG RVW: GILC: 1725619-A	PWILLIAM			
		Check GEN00021492:	<u>23,998.13</u>					
CONDUENT STATE & LOCAL SOLUTIC Revenue Fund		VO809269	83,060.73	OTHER CNTRCTUAL SVCS, MIR ; 1725619	DMA4TGAT	REV00016062	7/22/2024	545,611.93
		VO809270	106,439.29	OTHER CNTRCTUAL SVCS, MIR ; 1725625	DMA4TGAT			
		VO809271	120,474.57	OTHER CNTRCTUAL SVCS, MIR ; 1725630	DMA4TGAT			
		VO809273	117,309.56	OTHER CNTRCTUAL SVCS, MIR ; 1725717	DMA4TGAT			
		VO809272	<u>118,327.78</u>	OTHER CNTRCTUAL SVCS, MIR ; 1725715	DMA4TGAT			
		Check REV00016062:	<u>545,611.93</u>					
		<b>Total for CONDUENT STATE &amp; LOCAL SOLUTIONS, INC.:</b>	<b>569,610.06</b>					
CONE, TODD	Revenue Fund	VO808836	<u>195.64</u>	JULY 2024 EXPENSES	JPORTER	RRV00349748	7/16/2024	195.64
		Check RRV00349748:	<u>195.64</u>					
		<b>Total for CONE, TODD:</b>	<b>195.64</b>					
CONROY TAG AGENCY	Revenue Fund	VO808060	<u>265.00</u>	FEE/ISSUANCE 106 PIKEPASS 06/2024	APERINGO	RRV00349434	7/9/2024	265.00
		Check RRV00349434:	<u>265.00</u>					
		<b>Total for CONROY TAG AGENCY:</b>	<b>265.00</b>					
CONVERGINT TECHNOLOGIES LLC	Revenue Fund	VO809533	879.62	OTHER CONTRACTUAL SERVICES	JMELTON	RRV00350017	7/26/2024	2,110.62
		VO809535	<u>1,231.00</u>	ALARM MONITORING SERVICES	DMACHAME			
		Check RRV00350017:	<u>2,110.62</u>					
CONVERGINT TECHNOLOGIES LLC	Revenue Fund	VO810011	1,194.10	OTHER MAINTENANCE	TGORE	RRV00350118	7/31/2024	4,848.20
		VO810027	<u>3,654.10</u>	NONCAP RADIO/COMM EQUIP & OTHER SRVCS	MLOEFFEL			
		Check RRV00350118:	<u>4,848.20</u>					
		<b>Total for CONVERGINT TECHNOLOGIES LLC:</b>	<b>6,958.82</b>					
CORNER TAG AGENCY -- ASHLEY WIL	Revenue Fund	VO808062	<u>50.00</u>	FEE/ISSUANCE 20 PIKEPASS 06/2024	APERINGO	RRV00349435	7/9/2024	50.00
		Check RRV00349435:	<u>50.00</u>					
		<b>Total for CORNER TAG AGENCY -- ASHLEY WILLIAMS #88:</b>	<b>50.00</b>					
COTTON ELECTRIC COOP, INC	Revenue Fund	VO807482	<u>585.45</u>	ELECTRIC	BPATTERS	EFT018739	7/1/2024	585.45
		Check EFT018739:	<u>585.45</u>					
COTTON ELECTRIC COOP, INC	Revenue Fund	VO808068	<u>465.13</u>	ELECTRIC	BPATTERS	EFT018783	7/9/2024	465.13
		Check EFT018783:	<u>465.13</u>					
		<b>Total for COTTON ELECTRIC COOP, INC:</b>	<b>1,050.58</b>					
COWAN GROUP ENGINEERING, LLC.	Capital Projects	VO809631	23,345.00	T-26702A: M2 RDWY/BRG DSGN: 8738	DBUTLER	23A0000238	7/25/2024	56,815.00
		VO809632	6,790.00	T-26502A: M2 RDWY DSGN: 8737	DBUTLER			
		VO809630	<u>26,680.00</u>	T-26702B: M2 RDWY DSGN: 8739	DBUTLER			
		Check 23A0000238:	<u>56,815.00</u>					
COWAN GROUP ENGINEERING, LLC.	Capital Projects	VO810048	28,382.00	T-26502A: M2 RDWY DSGN/MAPPIN: 8844	DBUTLER	23A0000249	7/30/2024	28,382.00

Vendor Name	Fund Desc	Voucher NO.	Amt Applied	Description	Approver	Check No.	Date Paid	Amt Check
		Check 23A0000249:	28,382.00					
		<b>Total for COWAN GROUP ENGINEERING, LLC.:</b>	<b>85,197.00</b>					
COX COMMUNICATIONS	Revenue Fund	VO808298	24,091.68	CABLE	MLOEFFEL	EFT018789	7/11/2024	24,091.68
		Check EFT018789:	24,091.68					
		<b>Total for COX COMMUNICATIONS:</b>	<b>24,091.68</b>					
CP&Y	Capital Projects	VO808852	58,600.00	T-26611A: M1 DSGN/MGT: OTAY2200245.06-4	DBUTLER	23A0000230	7/16/2024	202,280.00
		VO808884	32,315.00	T-26711A: M2 RDWY DSGN: OTAY2200245.07-4	DBUTLER			
		VO808891	41,345.00	T-26706B: M2 RDWY/MGT: OTAY2200245.10-4	DBUTLER			
		VO808888	70,020.00	T-26606A: M2 RDWY DSGN: OTAY2200245.09-4	DBUTLER			
		Check 23A0000230:	202,280.00					
CP&Y	Capital Projects	VO809009	8,868.00	T-26511A: DSGN/MGT: OTAY2200245.40-4	DBUTLER	23A0000232	7/17/2024	8,868.00
		Check 23A0000232:	8,868.00					
CP&Y	Capital Projects	VO809951	124,735.00	T-26706B: M2 DSGN/MGMT: 2200245.10-5	TJDILL	23A0000248	7/29/2024	509,230.00
		VO809957	22,435.00	T-26511B: M2 DSGN/MGMT: 2200245.05-3	DBUTLER			
		VO809960	9,840.00	T-26811A: M2 RWY DDGN/MGMT: 2200245.08-2	DBUTLER			
		VO809961	330,795.00	T-26606A: DSGN/MGMT: 2200245.09-5	TJD4JECH			
		VO809953	21,425.00	T-26511B: M2 DSGN/MGMT: 2200245.05-2	DBUTLER			
		Check 23A0000248:	509,230.00					
		<b>Total for CP&amp;Y:</b>	<b>720,378.00</b>					
CRAFCO, INC.	Revenue Fund	VO807679	1,691.80	ASPHALT & CONCRETE	SALLEN	RRV00349262	7/3/2024	1,691.80
		Check RRV00349262:	1,691.80					
CRAFCO, INC.	Revenue Fund	VO808152	643.15	EQUIPMENT REPAIRS	DCRAIG	RRV00349520	7/10/2024	643.15
		Check RRV00349520:	643.15					
CRAFCO, INC.	Revenue Fund	VO808917	1,430.00	ASPHALT & CONCRETE SUPPLIES	MCOLLINS	RRV00349815	7/17/2024	1,430.00
		Check RRV00349815:	1,430.00					
CRAFCO, INC.	Revenue Fund	VO810043	237.80	EQUIPMENT PARTS & SUPPLIES	DCRAIG	RRV00350119	7/31/2024	4,772.80
		VO810039	2,940.00	OTHER ROAD MAINTENANCE SUPPLIES	MCOLLINS			
		VO810042	1,595.00	ASPHALT & CONCRETE SUPPLIES	MCOLLINS			
		Check RRV00350119:	4,772.80					
		<b>Total for CRAFCO, INC.:</b>	<b>8,537.75</b>					
CRAIG AND KEITHLINE CONSULTING	General	VO809039	9,900.00	WR-MC-124: OSR: INV# 22	JGARDER	GEN00021497	7/18/2024	9,900.00
		Check GEN00021497:	9,900.00					
		<b>Total for CRAIG AND KEITHLINE CONSULTING ENGINEERS:</b>	<b>9,900.00</b>					
CROSSLANDS A & A RENTAL	Revenue Fund	VO808962	106.00	EQUIPMENT RENTAL	PGOGGIN	RRV00349816	7/17/2024	106.00
		Check RRV00349816:	106.00					
		<b>Total for CROSSLANDS A &amp; A RENTAL:</b>	<b>106.00</b>					
CROW-BURLINGAME CO - CORPORA	Revenue Fund	VO807682	64.99	VEHICLE PARTS & SUPPLIES	RDTAYLOR	RRV00349263	7/3/2024	79.77
		VO807680	14.78	VEHICLE PARTS & SUPPLIES	RDTAYLOR			
		Check RRV00349263:	79.77					
CROW-BURLINGAME CO - CORPORA	Revenue Fund	VO808964	229.78	VEHICLE PARTS & SUPPLIES	RDTAYLOR	RRV00349817	7/17/2024	229.78
		Check RRV00349817:	229.78					

Vendor Name	Fund Desc	Voucher NO.	Amt Applied	Description	Approver	Check No.	Date Paid	Amt Check			
CROW-BURLINGAME CO - CORPORA	Revenue Fund	VO809538	201.91	VEHICLE PARTS & SUPPLIES	RDTAYLOR	RRV00350018	7/26/2024	745.11			
		VO809554	53.00	SMALL TOOLS & EQUIPMENT	RDTAYLOR						
		VO809537	420.00	VEHICLE PARTS & SUPPLIES	RDTAYLOR						
		VO809540	17.99	VEHICLE PARTS & SUPPLIES	RDTAYLOR						
		VO809539	36.73	VEHICLE PARTS & SUPPLIES	RDTAYLOR						
		VO809569	15.48	EQUIPMENT PARTS & SUPPLIES	RDTAYLOR						
		Check RRV00350018:	745.11								
CROW-BURLINGAME CO - CORPORA	Revenue Fund	VO810051	7.18	VEHICLE PARTS & SUPPLIES	RDTAYLOR	RRV00350120	7/31/2024	51.42			
		VO810054	44.24	VEHICLE PARTS & SUPPLIES	RDTAYLOR						
				Check RRV00350120:	51.42						
<b>Total for CROW-BURLINGAME CO - CORPORATE:</b>			<b>1,106.08</b>								
CRUM, MELISSA	Revenue Fund	VO808511	1,950.00	TRAINING AND EDUCATION	NTAGGART	RRV00349706	7/12/2024	1,950.00			
				Check RRV00349706:	1,950.00						
		<b>Total for CRUM, MELISSA:</b>			<b>1,950.00</b>						
CULLIGAN OF JOPLIN - KS	Revenue Fund	VO807684	45.45	BOTTLED DRINKING WATER & EQUIP RENTAL	JSMITH	RRV00349264	7/3/2024	45.45			
				Check RRV00349264:	45.45						
		<b>Total for CULLIGAN OF JOPLIN - KS:</b>			<b>45.45</b>						
CULLIGAN OF LAWTON	Revenue Fund	VO808965	11.50	EQUIPMENT RENTAL	KWALLIS	RRV00349819	7/17/2024	52.00			
		VO808967	40.50	BOTTLED DRINKING WATER & EQUIP RENTAL	KWALLIS						
				Check RRV00349819:	52.00						
		<b>Total for CULLIGAN OF LAWTON:</b>			<b>52.00</b>						
CULLIGAN OF TULSA	Revenue Fund	VO809572	9.00	EQUIPMENT RENTAL	JSMITH	RRV00350019	7/26/2024	9.00			
				Check RRV00350019:	9.00						
		<b>Total for CULLIGAN OF TULSA:</b>			<b>9.00</b>						
CULLIGAN WATER CONDITIONING	Revenue Fund	VO807683	56.56	BOTTLED DRINKING WATER	KDERVIN	RRV00349265	7/3/2024	56.56			
				Check RRV00349265:	56.56						
CULLIGAN WATER CONDITIONING	Revenue Fund	VO808968	71.11	EQUIPMENT RENTAL	CSTEVENS	RRV00349818	7/17/2024	71.11			
				Check RRV00349818:	71.11						
		<b>Total for CULLIGAN WATER CONDITIONING:</b>			<b>127.67</b>						
CURTIS RESTAURANT SUPPLY	Revenue Fund	VO807056	5,876.42	OFFICE EQUIPMENT	MCOLLINS	RRV00349276	7/3/2024	5,876.42			
				Check RRV00349276:	5,876.42						
		<b>Total for CURTIS RESTAURANT SUPPLY:</b>			<b>5,876.42</b>						
CUSHING TAG AGENCY	Revenue Fund	VO808063	125.00	FEE/ISSUANCE 50 PIKEPASS 06/2024	APERINGO	RRV00349436	7/9/2024	125.00			
				Check RRV00349436:	125.00						
		<b>Total for CUSHING TAG AGENCY:</b>			<b>125.00</b>						
D'S CATERING	Revenue Fund	VO807692	559.60	EMPLOYEE INCENTIVE AWARDS-FOOD, CATERING	RDTAYLOR	RRV00349269	7/3/2024	660.45			
		VO807693	100.85	BUSINESS EXPENSES	RDTAYLOR						
				Check RRV00349269:	660.45						
D'S CATERING	Revenue Fund	VO809586	329.49	TRAINING & EDUCATION	RDTAYLOR	RRV00350024	7/26/2024	593.09			
		VO809588	263.60	TRAINING & EDUCATION	RDTAYLOR						
				Check RRV00350024:	593.09						
		<b>Total for D'S CATERING:</b>			<b>1,253.54</b>						



Vendor Name	Fund Desc	Voucher NO.	Amt Applied	Description	Approver	Check No.	Date Paid	Amt Check
DAIN WISE	Revenue Fund	VO808820	207.70	JULY2024 EXPENSES	JEHELLE	RRV00349738	7/16/2024	207.70
		Check RRV00349738:	207.70					
		<b>Total for DAIN WISE:</b>	<b>207.70</b>					
DATA TRANSFER SOLUTIONS, LLC	Revenue Fund	VO808688	9,000.00	OTHER SFTWR/OTHER MAINT ; 1454503	ABOULDEN	REV00016040	7/15/2024	18,000.00
		VO808689	9,000.00	OTHER SFTWR/OTHER MAINT ; 1454547				
		Check REV00016040:	18,000.00					
DATA TRANSFER SOLUTIONS, LLC	Revenue Fund	VO809591	9,000.00	SOFTWARE/SUB RENEWAL & OTHER MAINT	MLOEFFEL	RRV00350020	7/26/2024	9,000.00
		Check RRV00350020:	9,000.00					
		<b>Total for DATA TRANSFER SOLUTIONS, LLC:</b>	<b>27,000.00</b>					
DAVIS TAG & INSURANCE AGENCY	Revenue Fund	VO808065	22.50	FEE/ISSUANCE 9 PIKEPASS 06/2024	APERINGO	RRV00349437	7/9/2024	22.50
		Check RRV00349437:	22.50					
		<b>Total for DAVIS TAG &amp; INSURANCE AGENCY:</b>	<b>22.50</b>					
DEL CITY TAG AGENCY - USE DECITA	Revenue Fund	VO808073	57.50	FEE/ISSUANCE 23 PIKEPASS 06/2024	APERINGO	RRV00349438	7/9/2024	57.50
		Check RRV00349438:	57.50					
		<b>Total for DEL CITY TAG AGENCY - USE DECITA02:</b>	<b>57.50</b>					
DELAWARE COUNTY RURAL WATER	Revenue Fund	VO808813	171.67	WATER	BPATTERS	EFT018810	7/16/2024	171.67
		Check EFT018810:	171.67					
		<b>Total for DELAWARE COUNTY RURAL WATER DIST #11:</b>	<b>171.67</b>					
DELL MARKETING L.P.	General	VO808526	7,399.00	NONCAP DATA PROCESS EQUIP ;10754614701	MLOEFFEL	GEN00021471	7/12/2024	7,399.00
		Check GEN00021471:	7,399.00					
		<b>Total for DELL MARKETING L.P.:</b>	<b>7,399.00</b>					
DEPARTMENT OF CORRECTIONS - I-35	Revenue Fund	VO809054	405.00	INMATE LABOR JUNE 2024	PGOGGIN	RRV00349830	7/18/2024	405.00
		Check RRV00349830:	405.00					
		<b>Total for DEPARTMENT OF CORRECTIONS - I-35:</b>	<b>405.00</b>					
DEPARTMENT OF ENVIRONMENTAL	Revenue Fund	VO808969	46.00	GOVERNMENTAL PERMITS & LICENSES	KWALLIS	RRV00349820	7/17/2024	46.00
		Check RRV00349820:	46.00					
DEPARTMENT OF ENVIRONMENTAL	Revenue Fund	VO809576	46.00	GOVERNMENT PERMITS & LICENSES	KWALLIS	RRV00350021	7/26/2024	46.00
		Check RRV00350021:	46.00					
DEPARTMENT OF ENVIRONMENTAL	Revenue Fund	VO810057	46.00	GOVERNMENTAL PERMITS & LICENSES	RROWEN	RRV00350121	7/31/2024	92.00
		VO810071	46.00	GOVERNMENTAL PERMITS & LICENSES				
		Check RRV00350121:	92.00					
<b>Total for DEPARTMENT OF ENVIRONMENTAL QUALITY:</b>			<b>184.00</b>					
DEPARTMENT OF PUBLIC SAFETY	General	VO807701	163,499.28	MAY 24'- 71ST CADET SCHOOL: TPK-000146	TJDILL	GEN00021448	7/3/2024	163,499.28
		Check GEN00021448:	163,499.28					
DEPARTMENT OF PUBLIC SAFETY	General	VO809910	164,036.79	JUNE 24'- 71ST CADET SCHOOL: TPK-000151	TJDILL	GEN00021532	7/29/2024	164,036.79
		Check GEN00021532:	164,036.79					
DEPARTMENT OF PUBLIC SAFETY	Revenue Fund	VO808953	1,248,153.29	MAY '24,OHP MTHLY PRSNL FEE;TPK-000143	TJD4JECH	REV00016044	7/17/2024	1,248,153.29
		Check REV00016044:	1,248,153.29					
DEPARTMENT OF PUBLIC SAFETY	Revenue Fund	VO809035	25,210.33	OTHER CNTRCTL SECURITY SVCS;TPK-000144	TJDILL	REV00016048	7/18/2024	25,210.33
		Check REV00016048:	25,210.33					

Vendor Name	Fund Desc	Voucher NO.	Amt Applied	Description	Approver	Check No.	Date Paid	Amt Check
DEPARTMENT OF PUBLIC SAFETY	Revenue Fund	VO808178	<u>11,242.33</u>	CELLULAR TELECOMMUNICATIONS	JSMITH	RRV00349524	7/10/2024	11,242.33
		Check RRV00349524:	11,242.33					
DEPARTMENT OF PUBLIC SAFETY	Revenue Fund	VO809999	<u>10,965.22</u>	CELLULAR TELECOMMUNICATIONS JUNE 2024	JSMITH	RRV00350066	7/29/2024	10,965.22
		Check RRV00350066:	10,965.22					
<b>Total for DEPARTMENT OF PUBLIC SAFETY:</b>			<b>1,623,107.24</b>					
DERVIN, KAREN	Revenue Fund	VO807623	<u>194.95</u>	JULY 2024 EXPENSES	JMELTON	RRV00349232	7/2/2024	194.95
		Check RRV00349232:	194.95					
DERVIN, KAREN	Revenue Fund	VO809347	<u>56.26</u>	JULY 2024 EXPENSES	JMELTON	RRV00350013	7/25/2024	105.86
		VO809352	<u>49.60</u>	JULY 2024 EXPENSES	JMELTON			
		Check RRV00350013:	105.86					
<b>Total for DERVIN, KAREN:</b>			<b>300.81</b>					
DIAMOND SURFACE, INC.	Reserve Maintenance	VO808260	<u>2,409,791.20</u>	IN-MC-62F ; ESTIMATE NO. 5	TJD4JECH	RMT00006043	7/10/2024	2,409,791.20
		Check RMT00006043:	2,409,791.20					
<b>Total for DIAMOND SURFACE, INC.:</b>			<b>2,409,791.20</b>					
DIAMOND TAG AGENCY - CHERYL R/	Revenue Fund	VO808076	<u>15.00</u>	FEE/ISSUANCE 6 PIKEPASS 06/2024	APERINGO	RRV00349439	7/9/2024	15.00
		Check RRV00349439:	15.00					
<b>Total for DIAMOND TAG AGENCY - CHERYL RAPER #4118:</b>			<b>15.00</b>					
DIRECT DISCOUNT TIRE, LLC.	Revenue Fund	VO807686	<u>453.74</u>	EQUIPMENT PARTS & REPAIRS	RROWEN	RRV00349266	7/3/2024	907.48
		VO807685	<u>453.74</u>	EQUIPMENT PARTS & REPAIRS	RROWEN			
		Check RRV00349266:	907.48					
DIRECT DISCOUNT TIRE, LLC.	Revenue Fund	VO808977	<u>45.00</u>	EQUIPMENT REPAIRS	RROWEN	RRV00349821	7/17/2024	45.00
		Check RRV00349821:	45.00					
DIRECT DISCOUNT TIRE, LLC.	Revenue Fund	VO810075	<u>356.54</u>	VEHICLE PARTS & REPAIRS	RROWEN	RRV00350122	7/31/2024	356.54
		Check RRV00350122:	356.54					
<b>Total for DIRECT DISCOUNT TIRE, LLC.:</b>			<b>1,309.02</b>					
DIRECT TRAFFIC CONTROL, INC.	Revenue Fund	VO810077	<u>1,750.00</u>	TRAFFIC CONTROL & SAFETY SUPPLIES	MCOLLINS	RRV00350123	7/31/2024	1,750.00
		Check RRV00350123:	1,750.00					
<b>Total for DIRECT TRAFFIC CONTROL, INC.:</b>			<b>1,750.00</b>					
DISCOUNT STEEL LLC	Revenue Fund	VO809577	<u>462.00</u>	FENCING SUPPLIES	BWESTER	RRV00350022	7/26/2024	462.00
		Check RRV00350022:	462.00					
DISCOUNT STEEL LLC	Revenue Fund	VO810078	<u>67.00</u>	BUILDING MAINTENANCE SUPPLIES	BWESTER	RRV00350124	7/31/2024	67.00
		Check RRV00350124:	67.00					
<b>Total for DISCOUNT STEEL LLC:</b>			<b>529.00</b>					
DISCOUNT TIRE-EXPRESSWAY	Revenue Fund	VO808486	<u>262.00</u>	VEHICLE PARTS & REPAIR	RDTAYLOR	RRV00349695	7/12/2024	262.00
		Check RRV00349695:	262.00					
<b>Total for DISCOUNT TIRE-EXPRESSWAY:</b>			<b>262.00</b>					
DISCOUNT TIRES/WISEMAN BROS., I	Revenue Fund	VO810082	<u>47.93</u>	EQUIPMENT REPAIRS	BCANTREL	RRV00350125	7/31/2024	95.86
		VO810090	<u>47.93</u>	EQUIPMENT REPAIRS	BCANTREL			
		Check RRV00350125:	95.86					
<b>Total for DISCOUNT TIRES/WISEMAN BROS., INC.:</b>			<b>95.86</b>					

Vendor Name	Fund Desc	Voucher NO.	Amt Applied	Description	Approver	Check No.	Date Paid	Amt Check
DISH	Revenue Fund	VO808487	1,671.44	CABLE SERVICE	JLYTLE	EFT018795	7/12/2024	1,671.44
		Check EFT018795:	1,671.44					
		<b>Total for DISH:</b>	<b>1,671.44</b>					
DOLESE	Revenue Fund	VO807687	1,516.00	ASPHALT & CONCRETE SUPPLIES	SALLEN	RRV00349267	7/3/2024	5,060.75
		VO807688	1,477.00	ASPHALT & CONCRETE SUPPLIES				
		VO807689	541.25	ASPHALT & CONCRETE SUPPLIES				
		VO807690	1,526.50	ASPHALT & CONCRETE SUPPLIES				
		Check RRV00349267:	5,060.75					
DOLESE	Revenue Fund	VO808195	2,022.00	ASPHALT & CONCRETE SUPPLIES	SALLEN	RRV00349522	7/10/2024	6,234.50
		VO808197	1,853.50	ASPHALT & CONCRETE SUPPLIES				
		VO808196	2,359.00	ASPHALT & CONCRETE SUPPLIES				
		Check RRV00349522:	6,234.50					
DOLESE	Revenue Fund	VO808980	2,696.00	ASPHALT & CONCRETE SUPPLIES	SALLEN	RRV00349822	7/17/2024	2,696.00
DOLESE	Revenue Fund	VO809579	1,368.00	ASPHALT & CONCRETE SUPPLIES	SALLEN	RRV00350023	7/26/2024	2,736.00
VO809585	1,368.00	ASPHALT & CONCRETE SUPPLIES						
Check RRV00350023:	2,736.00							
DOLESE	Revenue Fund	VO810092	284.20	OTHER ROAD MAINTENANCE SUPPLIES	PGOGGIN	RRV00350126	7/31/2024	1,608.20
		VO810093	1,324.00	ASPHALT & CONCRETE SUPPLIES				
		Check RRV00350126:	1,608.20					
		<b>Total for DOLESE:</b>	<b>18,335.45</b>					
DONOHUE COMMERCIAL SERVICE	Revenue Fund	VO807691	5,223.00	OTHER MAINTENANCE & ACCT. RECEIVABLE	JECHELLE	RRV00349268	7/3/2024	5,223.00
DONOHUE COMMERCIAL SERVICE	Revenue Fund	VO808204	362.00	OTHER MAINTENANCE	AHEITZ	RRV00349523	7/10/2024	5,585.00
		VO808206	5,223.00	ACCOUNTS RECEIVABLE & OTHER MAINTENANCE				
		Check RRV00349523:	5,585.00					
<b>Total for DONOHUE COMMERCIAL SERVICE:</b>			<b>10,808.00</b>					
DOUBLE J STORAGE, LLC	Revenue Fund	VO808078	157.50	FEE/ISSUANCE 63 PIKEPASS 06/2024	APERINGO	RRV00349440	7/9/2024	157.50
		Check RRV00349440:	157.50					
<b>Total for DOUBLE J STORAGE, LLC:</b>			<b>157.50</b>					
DOWNTOWN OKC TAG AGENCY	Revenue Fund	VO808081	57.50	FEE/ISSUANCE 23 PIKEPASS 06/2024	APERINGO	RRV00349441	7/9/2024	57.50
		Check RRV00349441:	57.50					
<b>Total for DOWNTOWN OKC TAG AGENCY:</b>			<b>57.50</b>					
DRUMRIGHT TAG AGENCY LLC	Revenue Fund	VO808082	30.00	FEE/ISSUANCE 12 PIKEPASS 06/2024	APERINGO	RRV00349442	7/9/2024	30.00
		Check RRV00349442:	30.00					
<b>Total for DRUMRIGHT TAG AGENCY LLC:</b>			<b>30.00</b>					
DUB ROSS COMPANY, INC.	Revenue Fund	VO807694	902.80	DRAINAGE & CULVERTS	RDTAYLOR	RRV00349270	7/3/2024	902.80
		Check RRV00349270:	902.80					
<b>Total for DUB ROSS COMPANY, INC.:</b>			<b>902.80</b>					
DUIT CONSTRUCTION CO, INC	Capital Projects	VO808125	3,407,641.39	T-MC-107A1/A2/B3: ESTIMATE NO. 4	TJD4JECH	23A0000224	7/9/2024	3,407,641.39
		Check 23A0000224:	3,407,641.39					

Vendor Name	Fund Desc	Voucher NO.	Amt Applied	Description	Approver	Check No.	Date Paid	Amt Check
<b>Total for DUIT CONSTRUCTION CO, INC:</b>			<b>3,407,641.39</b>					
DUNCAN NORTHSIDE TAG OFFICE	Revenue Fund	VO808083	130.00	FEE/ISSUANCE 52 PIKEPASS 06/2024	APERINGO	RRV00349443	7/9/2024	130.00
		Check RRV00349443:	130.00					
<b>Total for DUNCAN NORTHSIDE TAG OFFICE:</b>			<b>130.00</b>					
DUNCAN TAG AGENCY	Revenue Fund	VO808085	137.50	FEE/ISSUANCE 55 PIKEPASS 06/2024	APERINGO	RRV00349444	7/9/2024	137.50
		Check RRV00349444:	137.50					
<b>Total for DUNCAN TAG AGENCY:</b>			<b>137.50</b>					
E&A AUTO LLC	Revenue Fund	VO807696	74.57	EQUIPMENT PARTS & SUPPLIES	CSTEVENS	RRV00349271	7/3/2024	74.57
		Check RRV00349271:	74.57					
E&A AUTO LLC	Revenue Fund	VO808981	11.61	VEHICLE PARTS & SUPPLIES	CSTEVENS	RRV00349823	7/17/2024	11.61
		Check RRV00349823:	11.61					
<b>Total for E&amp;A AUTO LLC:</b>			<b>86.18</b>					
E-Z SHIP AND COPY	Revenue Fund	VO808113	22.50	FEE/ISSUANCE 9 PIKEPASS 06/2024	APERINGO	RRV00349452	7/9/2024	22.50
		Check RRV00349452:	22.50					
<b>Total for E-Z SHIP AND COPY:</b>			<b>22.50</b>					
EAGLE REDI-MIX CONCRETE, LLC	Revenue Fund	VO810098	497.00	ASPHALT & CONCRETE SUPPLIES	CHUGHES	RRV00350128	7/31/2024	497.00
		Check RRV00350128:	497.00					
<b>Total for EAGLE REDI-MIX CONCRETE, LLC:</b>			<b>497.00</b>					
EAST CENTRAL OKLAHOMA ELECTRIC	Revenue Fund	VO808012	180.73	ELECTRIC	BPATTERS	EFT018776	7/9/2024	180.73
		Check EFT018776:	180.73					
EAST CENTRAL OKLAHOMA ELECTRIC	Revenue Fund	VO808814	2,534.00	ELECTRIC	BPATTERS	EFT018807	7/16/2024	2,534.00
		Check EFT018807:	2,534.00					
<b>Total for EAST CENTRAL OKLAHOMA ELECTRIC COOPERATI:</b>			<b>2,714.73</b>					
EASTSIDE TAG AGENCY	Revenue Fund	VO808089	240.00	FEE/ISSUANCE 96 PIKEPASS 06/2024	APERINGO	RRV00349445	7/9/2024	240.00
		Check RRV00349445:	240.00					
<b>Total for EASTSIDE TAG AGENCY:</b>			<b>240.00</b>					
EASTSIDE WASTE SYSTEMS, INC.	Revenue Fund	VO809555	278.00	SOLID WASTE/TRASH DISPOSAL	RDTAYLOR	RRV00350006	7/25/2024	278.00
		Check RRV00350006:	278.00					
<b>Total for EASTSIDE WASTE SYSTEMS, INC.:</b>			<b>278.00</b>					
ECO MANAGEMENT INC.	Revenue Fund	VO808207	1,360.00	LANDSCAPING SERVICES	TJDILL	RRV00349525	7/10/2024	1,360.00
		Check RRV00349525:	1,360.00					
<b>Total for ECO MANAGEMENT INC.:</b>			<b>1,360.00</b>					
EDMOND TAG AGENCY	Revenue Fund	VO808092	195.00	FEE/ISSUANCE 78 PIKEPASS 06/2024	APERINGO	RRV00349446	7/9/2024	195.00
		Check RRV00349446:	195.00					
<b>Total for EDMOND TAG AGENCY:</b>			<b>195.00</b>					
EGL LAW, PLLC	General	VO807670	160.00	GENERAL CNSEL DF PRGRM SVC: INV# 1369	JPORTER	GEN00021444	7/3/2024	980.00
		VO807673	160.00	GENERAL CNSEL GILC PRGRM SVC: INV# 1370	JPORTER			
		VO807669	660.00	GENERAL CNSEL ACCES PRGRM SVC: INV# 1368	JPORTER			
		Check GEN00021444:	980.00					
EGL LAW, PLLC	Revenue Fund	VO808692	24,152.38	GNRL CNSL, LEGAL SVCS, MAY 2024 ; 1367	JEHELLE	REV00016041	7/15/2024	24,152.38

Vendor Name	Fund Desc	Voucher NO.	Amt Applied	Description	Approver	Check No.	Date Paid	Amt Check
		Check REV00016041:	24,152.38					
		<b>Total for EGL LAW, PLLC:</b>	<b>25,132.38</b>					
EL RENO TAG AGENCY - #0929	Revenue Fund	VO808096	185.00	FEE/ISSUANCE 74 PIKEPASS 06/2024	APERINGO	RRV00349449	7/9/2024	185.00
		Check RRV00349449:	185.00					
		<b>Total for EL RENO TAG AGENCY - #0929:</b>	<b>185.00</b>					
ELGIN TAG AGENCY	Revenue Fund	VO808098	275.00	FEE/ISSUANCE 110 PIKEPASS 06/2024	APERINGO	RRV00349447	7/9/2024	275.00
		Check RRV00349447:	275.00					
		<b>Total for ELGIN TAG AGENCY:</b>	<b>275.00</b>					
ELK CITY TAG AGENCY LLC	Revenue Fund	VO808101	77.50	FEE/ISSUANCE 31 PIKEPASS 06/2024	APERINGO	RRV00349448	7/9/2024	77.50
		Check RRV00349448:	77.50					
		<b>Total for ELK CITY TAG AGENCY LLC:</b>	<b>77.50</b>					
EMERY SAPP & SONS, INC.	General	VO807661	225,203.81	WR-MC-144: ESTIMATE NO. 1	TJDILL	GEN00021443	7/3/2024	225,203.81
		Check GEN00021443:	225,203.81					
EMERY SAPP & SONS, INC.	General	VO808064	3,929,885.10	WR-MC-144: ESTIMATE NO. 2	TJD4JECH	GEN00021457	7/9/2024	3,929,885.10
		Check GEN00021457:	3,929,885.10					
		<b>Total for EMERY SAPP &amp; SONS, INC.:</b>	<b>4,155,088.91</b>					
ENID TAG AGENCY #2419	Revenue Fund	VO808103	230.00	FEE/ISSUANCE 92 PIKEPASS 06/2024	APERINGO	RRV00349450	7/9/2024	230.00
		Check RRV00349450:	230.00					
		<b>Total for ENID TAG AGENCY #2419:</b>	<b>230.00</b>					
EPICOR SOFTWARE CORP	Revenue Fund	VO808492	68,987.29	ANNUAL SFTWR RENEW ; MRIV100-10883809	ABOULDEN	REV00016029	7/12/2024	68,987.29
		Check REV00016029:	68,987.29					
		<b>Total for EPICOR SOFTWARE CORP:</b>	<b>68,987.29</b>					
ERGON ASPHALT & EMULSIONS, INC	Revenue Fund	VO808208	443.77	ASPHALT & CONCRETE SUPPLIES	DCRAIG	RRV00349526	7/10/2024	443.77
		Check RRV00349526:	443.77					
		<b>Total for ERGON ASPHALT &amp; EMULSIONS, INC.:</b>	<b>443.77</b>					
EST, INC.	Capital Projects	VO809869	66,586.46	T-26712B: CON INSPCTN: R-024283-000-1	TJDILL	23A0000245	7/29/2024	66,586.46
		Check 23A0000245:	66,586.46					
EST, INC.	General	VO809639	16,409.20	MU-MC-53: PF PLN/FNL BD: 2-303141-000-11	DBUTLER	GEN00021520	7/26/2024	16,409.20
		Check GEN00021520:	16,409.20					
EST, INC.	Reserve Maintenance	VO808659	8,650.97	IN-MC-61, FINAL BID PLNS, ADVRT	TJDILL	RMT00006047	7/15/2024	8,650.97
		Check RMT00006047:	8,650.97					
EST, INC.	Reserve Maintenance	VO810059	3,531.67	ADVRT & BID, IN-MC-62 ;6-009205-000-42	TJD4JECH	RMT00006055	7/30/2024	3,531.67
		Check RMT00006055:	3,531.67					
		<b>Total for EST, INC.:</b>	<b>95,178.30</b>					
EUREKA WATER COMPANY, INC.	Revenue Fund	VO807697	22.35	BOTTLED DRINKING WATER	PGOGGIN	RRV00349272	7/3/2024	22.35
		Check RRV00349272:	22.35					
EUREKA WATER COMPANY, INC.	Revenue Fund	VO808212	39.24	EQUIPMENT RENTAL	PGOGGIN	RRV00349527	7/10/2024	201.23
		VO808239	161.99	EQUIPMENT RENTAL	KWALLIS			
		Check RRV00349527:	201.23					

Vendor Name	Fund Desc	Voucher NO.	Amt Applied	Description	Approver	Check No.	Date Paid	Amt Check
EUREKA WATER COMPANY, INC.	Revenue Fund	VO809280	149.00	BOTTLED DRINKING WATER	TJDILL	RRV00349899	7/22/2024	149.00
		Check RRV00349899:	149.00					
EUREKA WATER COMPANY, INC.	Revenue Fund	VO809556	7.45	BOTTLED DRINKING WATER	KWALLIS	RRV00350007	7/25/2024	7.45
		Check RRV00350007:	7.45					
EUREKA WATER COMPANY, INC.	Revenue Fund	VO810100	149.00	BOTTLED DRINKING WATER	TGORE PGOGGIN	RRV00350129	7/31/2024	178.80
		VO810099	29.80	BOTTLED DRINKING WATER				
		Check RRV00350129:	178.80					
<b>Total for EUREKA WATER COMPANY, INC.:</b>			<b>558.83</b>					
EXPRESS TAG AGENCY	Revenue Fund	VO808111	80.00	FEE/ISSUANCE 32 PIKEPASS 06/2024	APERINGO	RRV00349451	7/9/2024	80.00
		Check RRV00349451:	80.00					
<b>Total for EXPRESS TAG AGENCY:</b>			<b>80.00</b>					
EXPRESSWAY FINA & TIRE, INC.	Revenue Fund	VO809600	20.00	EQUIPMENT REPAIRS	KWALLIS	RRV00350025	7/26/2024	20.00
		Check RRV00350025:	20.00					
<b>Total for EXPRESSWAY FINA &amp; TIRE, INC.:</b>			<b>20.00</b>					
F/X TECHNOLOGIES	Revenue Fund	VO807714	543.50	NONCAP RADIO EQUIP & OTHER SRVCS	RDTAYLOR	RRV00349317	7/5/2024	543.50
		Check RRV00349317:	543.50					
<b>Total for F/X TECHNOLOGIES:</b>			<b>543.50</b>					
FAGAN CONSULTING, LLC	General	VO808209	779.38	PROF CNSLTNG SVC: JUNE 24: OTA-2406	MBISWELL	GEN00021463	7/10/2024	779.38
		Check GEN00021463:	779.38					
<b>Total for FAGAN CONSULTING, LLC:</b>			<b>779.38</b>					
FARM & RANCH CENTER	Revenue Fund	VO808984	124.00	INSECTICIDES & HERBICIDES	CSTEVENS	RRV00349824	7/17/2024	124.00
		Check RRV00349824:	124.00					
<b>Total for FARM &amp; RANCH CENTER:</b>			<b>124.00</b>					
FASTENAL COMPANY	Revenue Fund	VO807698	80.25	HARDWARE	RDTAYLOR MCOLLINS MCOLLINS MCOLLINS MCOLLINS	RRV00349273	7/3/2024	1,089.84
		VO807700	164.99	SMALL TOOLS & EQUIPMENT				
		VO807702	508.84	OTHER COMMODITIES & SUPPLIES				
		VO807703	54.48	HARDWARE				
		VO807699	281.28	SAFETY & MEDICAL SUPPLIES				
Check RRV00349273:	1,089.84							
FASTENAL COMPANY	Revenue Fund	VO810102	45.70	HARDWARE	DCRAIG JJENKINS	RRV00350130	7/31/2024	205.21
		VO810101	159.51	HARDWARE				
		Check RRV00350130:	205.21					
<b>Total for FASTENAL COMPANY:</b>			<b>1,295.05</b>					
FECHNER PUMP & SUPPLY, INC.	Revenue Fund	VO807704	473.76	OTHER COMMODITIES & SUPPLIES	RDTAYLOR	RRV00349274	7/3/2024	473.76
		Check RRV00349274:	473.76					
FECHNER PUMP & SUPPLY, INC.	Revenue Fund	VO809609	414.96	OTHER COMMODITIES & SUPPLIES	JSMART	RRV00350026	7/26/2024	414.96
		Check RRV00350026:	414.96					
		<b>Total for FECHNER PUMP &amp; SUPPLY, INC.:</b>						
FENSCO, INC	Revenue Fund	VO808718	5,250.00	TRAFFIC CNTRL & SFTY SUPP ; 24-0619-03	MCOLLINS MCOLLINS MCOLLINS MCOLLINS	REV00016042	7/15/2024	18,699.60
		VO808719	6,691.97	TRAFFIC CNTRL & SFTY SUPPLIES ; 64440				
		VO808722	2,975.00	TRAFFIC CNTRL & SFTY SUPP ; 24-0619-02				
		VO808723	3,782.63	OTHER CNTRCTUAL SVCS ; 24-0619-01				

Vendor Name	Fund Desc	Voucher NO.	Amt Applied	Description	Approver	Check No.	Date Paid	Amt Check
		Check REV00016042:	18,699.60					
FENSCO, INC	Revenue Fund	VO810007	15,230.14	TRAFFIC CNTRL & SFTY SUPPLIES ; 65286	SALLEN	REV00016077	7/29/2024	15,230.14
		Check REV00016077:	15,230.14					
FENSCO, INC	Revenue Fund	VO808988	951.19	TRAFFIC CONTROL & SAFETY SUPPLIES	PGOGGIN	RRV00349825	7/17/2024	7,002.69
		VO808990	6,051.50	OTHER SRVCS & TRAFFIC CNTRL/SAFETY SUPPL	MCOLLINS			
		Check RRV00349825:	7,002.69					
FENSCO, INC	Revenue Fund	VO809621	530.66	TRAFFIC CONTROL & SAFETY SUPPLY	RDTAYLOR	RRV00350027	7/26/2024	3,083.71
		VO809623	1,385.45	TRAFFIC CONTROL & SAFETY SUPPLIES	MCOLLINS			
		VO809622	1,167.60	DRAINAGE & CULVERTS	MCOLLINS			
		Check RRV00350027:	3,083.71					
FENSCO, INC	Revenue Fund	VO810103	3,692.40	TRAFFIC CONTROL & SAFETY SUPPLIES	MCOLLINS	RRV00350131	7/31/2024	5,354.90
		VO810104	1,662.50	TRAFFIC CONTROL SUPPLIES& OTHER SERVICES	MCOLLINS			
		Check RRV00350131:	5,354.90					
		<b>Total for FENSCO, INC:</b>	<b>49,371.04</b>					
FENTON FORD OF ADA, INC.	Revenue Fund	VO808114	30.00	FEE/ISSUANCE 12 PIKEPASS 06/2024	APERINGO	RRV00349454	7/9/2024	30.00
		Check RRV00349454:	30.00					
		<b>Total for FENTON FORD OF ADA, INC.:</b>	<b>30.00</b>					
FENTON MOTORS, INC.	Revenue Fund	VO808117	62.50	FEE/ISSUANCE 25 PIKEPASS 06/2024	APERINGO	RRV00349453	7/9/2024	62.50
		Check RRV00349453:	62.50					
		<b>Total for FENTON MOTORS, INC.:</b>	<b>62.50</b>					
FERRELLGAS, LP	Revenue Fund	VO807705	896.31	NATURAL & PROPANE GAS	KINMAN	RRV00349275	7/3/2024	896.31
		Check RRV00349275:	896.31					
		<b>Total for FERRELLGAS, LP:</b>	<b>896.31</b>					
FINE AIRPORT PARKING, INC.	Revenue Fund	VO808138	7.50	FEE/ISSUANCE 3 PIKEPASS 06/2024	APERINGO	RRV00349459	7/10/2024	7.50
		Check RRV00349459:	7.50					
		<b>Total for FINE AIRPORT PARKING, INC.:</b>	<b>7.50</b>					
FIRST CHOICE COFFEE SERVICES	Revenue Fund	VO809281	247.46	OTHER COMMODITIES & SUPPLIES	TGORE	RRV00349900	7/22/2024	247.46
		Check RRV00349900:	247.46					
		<b>Total for FIRST CHOICE COFFEE SERVICES:</b>	<b>247.46</b>					
FIZZ-O WATER COMPANY	Revenue Fund	VO807707	62.65	BOTTLED DRINKING WATER	AHEITZ	RRV00349318	7/5/2024	216.55
		VO807713	153.90	BOTTLED DRINKING WATER	BCANTREL			
		Check RRV00349318:	216.55					
FIZZ-O WATER COMPANY	Revenue Fund	VO808375	77.40	BOTTLED DRINKING WATER	BCANTREL	RRV00349696	7/12/2024	187.90
		VO808376	21.00	EQUIPMENT RENTAL	BCANTREL			
		VO808355	35.80	BOTTLED DRINKING WATER	AHEITZ			
		VO808363	53.70	BOTTLED DRINKING WATER	AHEITZ			
		Check RRV00349696:	187.90					
FIZZ-O WATER COMPANY	Revenue Fund	VO809007	410.85	BOTTLED DRINKING WATER	MCOLLINS	RRV00349826	7/17/2024	1,544.25
		VO809010	77.40	BOTTLED DRINKING WATER	BCANTREL			
		VO809008	1,056.00	SAFETY & MEDICAL SUPPLIES	MCOLLINS			
		Check RRV00349826:	1,544.25					

Vendor Name	Fund Desc	Voucher NO.	Amt Applied	Description	Approver	Check No.	Date Paid	Amt Check
FIZZ-O WATER COMPANY	Revenue Fund	VO809626	26.85	BOTTLED DRINKING WATER	AHEITZ	RRV00350028	7/26/2024	26.85
		Check RRV00350028:	26.85					
		<b>Total for FIZZ-O WATER COMPANY:</b>	<b>1,975.55</b>					
FLEETPRIDE	Revenue Fund	VO809011	101.75	VEHICLE PARTS & SUPPLIES	BCANTREL	RRV00349827	7/17/2024	101.75
		Check RRV00349827:	101.75					
FLEETPRIDE	Revenue Fund	VO809627	35.54	EQUIPMENT PARTS & SUPPLIES	PGOGGIN	RRV00350029	7/26/2024	35.54
		Check RRV00350029:	35.54					
FLEETPRIDE	Revenue Fund	VO810108	146.98	VEHICLE PARTS & SUPPLIES	BCANTREL	RRV00350132	7/31/2024	524.14
		VO810111	27.84	VEHICLE PARTS & SUPPLIES				
		VO810113	110.38	VEHICLE PARTS & SUPPLIES				
		VO810110	238.94	VEHICLE PARTS & SUPPLIES				
		Check RRV00350132:	524.14					
<b>Total for FLEETPRIDE:</b>	<b>661.43</b>							
FOREST RIDGE TAG AGENCY	Revenue Fund	VO808139	320.00	FEE/ISSUANCE 128 PIKEPASS 06/2024	APERINGO	RRV00349460	7/10/2024	320.00
		Check RRV00349460:	320.00					
		<b>Total for FOREST RIDGE TAG AGENCY:</b>	<b>320.00</b>					
FORESTRY SUPPLIERS, INC.	Revenue Fund	VO810114	247.22	INSECTICIDES & HERBICIDES	DCRAIG	RRV00350133	7/31/2024	247.22
		Check RRV00350133:	247.22					
		<b>Total for FORESTRY SUPPLIERS, INC.:</b>	<b>247.22</b>					
FORT GIBSON TAG AGENCY LLC-5116	Revenue Fund	VO808141	80.00	FEE/ISSUANCE 32 PIKEPASS 06/2024	APERINGO	RRV00349461	7/10/2024	80.00
		Check RRV00349461:	80.00					
		<b>Total for FORT GIBSON TAG AGENCY LLC-5116:</b>	<b>80.00</b>					
FREEDOM FORD	Revenue Fund	VO809012	27.16	EQUIPMENT PARTS & SUPPLIES	BELLIS	RRV00349828	7/17/2024	27.16
		Check RRV00349828:	27.16					
FREEDOM FORD	Revenue Fund	VO809628	705.14	VEHICLE PARTS & SUPPLIES	BWESTER	RRV00350030	7/26/2024	705.14
		Check RRV00350030:	705.14					
		<b>Total for FREEDOM FORD:</b>	<b>732.30</b>					
FREESE AND NICHOLS, INC.	General	VO809687	1,703.94	JKT-MC-15: PRJT MGR: 0001372380	JGARDER	GEN00021521	7/26/2024	3,173.94
		VO809684	1,470.00	HEB-MC-65C: PRJT MGR/RS ENG: 0001372383				
		Check GEN00021521:	3,173.94					
FREESE AND NICHOLS, INC.	Reserve Maintenance	VO810061	3,662.11	5A&5B CNSTRCTION, 2C PLANS,HEB-MC-69	TJD4JECH	RMT00006056	7/30/2024	3,662.11
		Check RMT00006056:	3,662.11					
		<b>Total for FREESE AND NICHOLS, INC.:</b>	<b>6,836.05</b>					
FRONTIER BRIDGE, INC.	General	VO807638	789,149.51	C-MC-30: ESTIMATE NO. 7	TJD4JECH	GEN00021440	7/2/2024	789,149.51
		Check GEN00021440:	789,149.51					
		<b>Total for FRONTIER BRIDGE, INC.:</b>	<b>789,149.51</b>					
FUSON TAG AGENCY	Revenue Fund	VO808142	265.00	FEE/ISSUANCE 106 PIKEPASS 06/2024	APERINGO	RRV00349462	7/10/2024	265.00
		Check RRV00349462:	265.00					
		<b>Total for FUSON TAG AGENCY:</b>	<b>265.00</b>					
GALT FOUNDATION	General	VO808300	948.87	OTHER PROFESSIONAL SVCS ; 050969	ABOULDEN	GEN00021468	7/11/2024	1,922.07
		VO808299	973.20	OTHER PROFESSIONAL SVCS ; 050795				



Vendor Name	Fund Desc	Voucher NO.	Amt Applied	Description	Approver	Check No.	Date Paid	Amt Check
		Check GEN00021468:	1,922.07					
GALT FOUNDATION	General	VO809619	839.39	OTHER PROFESSIONAL SVCS ; 051407	ABOULDEN	GEN00021519	7/25/2024	2,518.16
		VO809614	900.21	OTHER PROFESSIONAL SVCS ; 051057	ABOULDEN			
		VO809617	778.56	OTHER PROFESSIONAL SVCS ; 051270	ABOULDEN			
		Check GEN00021519:	2,518.16					
		<b>Total for GALT FOUNDATION:</b>	<b>4,440.23</b>					
GANNETT FLEMING, INC.	General	VO809330	1,941.68	VEHICLE CLASSIFICATION TECH ; 0000036581	DMA4TGAT	GEN00021509	7/24/2024	2,288.51
		VO809329	346.83	VEHICLE CLASSIFICATION TECH ; 0000034594	DMA4TGAT			
		Check GEN00021509:	2,288.51					
		<b>Total for GANNETT FLEMING, INC.:</b>	<b>2,288.51</b>					
GARNETT TAG AGENCY SOK-BARRY STEVESON	Revenue Fund	VO808143	490.00	FEE/ISSUANCE 196 PIKEPASS 06/2024	APERINGO	RRV00349463	7/10/2024	490.00
		Check RRV00349463:	490.00					
		<b>Total for GARNETT TAG AGENCY SOK-BARRY STEVESON:</b>	<b>490.00</b>					
GARVER, LLC	Capital Projects	VO809662	33,100.00	WR-31606A: M2 DSGN/SRVY: 22T25101-TO3-2	DBUTLER	23A0000239	7/26/2024	89,832.20
		VO809663	56,732.20	WR-31006: M1 DSGN/STUDY: 22T25101-TO1-11	DBUTLER			
		Check 23A0000239:	89,832.20					
GARVER, LLC	General	VO809051	1,793.25	T-MC-107B: CON SVCS: # 15037190-58	DBUTLER	GEN00021498	7/19/2024	1,793.25
		Check GEN00021498:	1,793.25					
GARVER, LLC	Reserve Maintenance	VO809333	27,760.50	IN-MC-62F,RES ENG,INSP,PROJ MAN,TRAVEL	TJD4JECH	RMT00006051	7/23/2024	27,760.50
		Check RMT00006051:	27,760.50					
GARVER, LLC	Reserve Maintenance	VO810063	34,485.09	IN-MC-62F,RES ENG,INSP,TRAVEL,TESTING	TJD4JECH	RMT00006057	7/30/2024	34,485.09
		Check RMT00006057:	34,485.09					
		<b>Total for GARVER, LLC:</b>	<b>153,871.04</b>					
GAYLA'S TAG AGENCY LLC	Revenue Fund	VO808144	120.00	FEE/ISSUANCE 48 PIKEPASS 06/2024	APERINGO	RRV00349464	7/10/2024	120.00
		Check RRV00349464:	120.00					
		<b>Total for GAYLA'S TAG AGENCY LLC:</b>	<b>120.00</b>					
GDH CONSULTING INC	Revenue Fund	VO809002	5,160.00	OTHER PROFESSIONAL SVCS ; 512152	JP4JECH	REV00016066	7/22/2024	20,640.00
		VO809005	5,160.00	OTHER PROFESSIONAL SVCS ; 515089	JP4JECH			
		VO809003	5,160.00	OTHER PROFESSIONAL SVCS ; 514368	JP4JECH			
		VO809004	5,160.00	OTHER PROFESSIONAL SVCS ; 514597	JP4JECH			
		Check REV00016066:	20,640.00					
GDH CONSULTING INC	Revenue Fund	VO809034	5,160.00	OTHER PROFESSIONAL SERVICES	ABOULDEN	RRV00349943	7/24/2024	9,288.00
		VO809036	4,128.00	OTHER PROFESSIONAL SERVICES	ABOULDEN			
		Check RRV00349943:	9,288.00					
		<b>Total for GDH CONSULTING INC:</b>	<b>29,928.00</b>					
GENE BURK AUTO GLASS OF LAWTON	Revenue Fund	VO808145	92.50	FEE/ISSUANCE 37 PIKEPASS 06/2024	APERINGO	RRV00349465	7/10/2024	92.50
		Check RRV00349465:	92.50					
		<b>Total for GENE BURK AUTO GLASS OF LAWTON:</b>	<b>92.50</b>					
GLENPOOL TAG AGENCY LLC - #7254	Revenue Fund	VO808146	130.00	FEE/ISSUANCE 52 PIKEPASS 06/2024	APERINGO	RRV00349466	7/10/2024	130.00
		Check RRV00349466:	130.00					
		<b>Total for GLENPOOL TAG AGENCY LLC - #7254:</b>	<b>130.00</b>					

Vendor Name	Fund Desc	Voucher NO.	Amt Applied	Description	Approver	Check No.	Date Paid	Amt Check
GOLDSBY TAG AGENCY - 4411	Revenue Fund	VO808147	42.50	FEE/ISSUANCE 17 PIKEPASS 06/2024	APERINGO	RRV00349467	7/10/2024	42.50
		Check RRV00349467:	42.50					
		<b>Total for GOLDSBY TAG AGENCY - 4411:</b>	<b>42.50</b>					
GONZALEZ PEST CONTROL	Revenue Fund	VO809043	35.00	PEST CONTROL SERVICES	AHEITZ	RRV00349878	7/19/2024	35.00
		Check RRV00349878:	35.00					
		<b>Total for GONZALEZ PEST CONTROL:</b>	<b>35.00</b>					
GOODMAN'S TIRE AND LUBE	Revenue Fund	VO807716	147.90	EQUIPMENT PARTS & REPAIRS	RDTAYLOR	RRV00349319	7/5/2024	147.90
		Check RRV00349319:	147.90					
GOODMAN'S TIRE AND LUBE	Revenue Fund	VO809044	20.00	EQUIPMENT REPAIR	RDTAYLOR	RRV00349879	7/19/2024	20.00
		Check RRV00349879:	20.00					
GOODMAN'S TIRE AND LUBE	Revenue Fund	VO809561	20.00	EQUIPMENT REPAIRS	RDTAYLOR	RRV00350008	7/25/2024	40.00
		VO809558	20.00	EQUIPMENT REPAIRS				
		Check RRV00350008:	40.00					
		<b>Total for GOODMAN'S TIRE AND LUBE:</b>	<b>207.90</b>					
GRAINGER - DEPT 832679427	Revenue Fund	VO807725	131.95	CLEANING & JANITORIAL SUPPLIES	DCRAIG	RRV00349332	7/5/2024	200.05
		VO807731	7.86	CLEANING & JANITORIAL SUPPLIES				
		VO807732	47.44	BUILDING MAINTENANCE SUPPLIES				
		VO807733	12.80	HARDWARE & OTHER SUPPLIES				
		Check RRV00349332:	200.05					
GRAINGER - DEPT 832679427	Revenue Fund	VO807981	145.62	SAFETY & MEDICAL SUPPLIES	DCRAIG	RRV00349381	7/8/2024	145.62
		Check RRV00349381:	145.62					
GRAINGER - DEPT 832679427	Revenue Fund	VO808380	1,529.64	NONCAPITALIZABLE EQUIPMENT	MCOLLINS	RRV00349708	7/12/2024	2,142.80
		VO808378	330.00	SAFETY & MEDICAL SUPPLIES				
		VO808392	283.16	VEHICLE, MAINT, OTHER SUPPL & SMALL TOOL				
		Check RRV00349708:	2,142.80					
GRAINGER - DEPT 832679427	Revenue Fund	VO809048	297.48	SAFETY & MEDICAL SUPPLIES	DCRAIG	RRV00349891	7/19/2024	360.86
		VO809045	63.38	CLEANING & JANITORIAL SUPPLIES				
		Check RRV00349891:	360.86					
GRAINGER - DEPT 832679427	Revenue Fund	VO809287	122.38	BUILDING & OTHER MAINTENANCE SUPPLIES	TGOORE	RRV00349905	7/22/2024	150.98
		VO809286	28.60	BUILDING MAINTENANCE SUPPLIES				
		Check RRV00349905:	150.98					
GRAINGER - DEPT 832679427	Revenue Fund	VO809633	1,529.64	NONCAPITALIZABLE EQUIPMENT	MCOLLINS	RRV00350039	7/26/2024	1,529.64
		Check RRV00350039:	1,529.64					
GRAINGER - DEPT 832679427	Revenue Fund	VO810117	30.63	SAFETY & MEDICAL SUPPLIES	DCRAIG	RRV00350136	7/31/2024	776.00
		VO810119	263.25	SAFETY & MEDICAL SUPPLIES				
		VO810115	364.83	SAFETY & CLEANING SUPPLIES				
		VO810120	86.66	EQUIPMENT PARTS & SUPPLIES				
		VO810118	30.63	SAFETY & MEDICAL SUPPLIES				
		Check RRV00350136:	776.00					
<b>Total for GRAINGER - DEPT 832679427:</b>	<b>5,305.95</b>							
GRAINGER - DEPT 834637282	Revenue Fund	VO807723	137.59	SAFETY & MEDICAL SUPPLIES	JJENKINS	RRV00349320	7/5/2024	137.59
		Check RRV00349320:	137.59					

Vendor Name	Fund Desc	Voucher NO.	Amt Applied	Description	Approver	Check No.	Date Paid	Amt Check
GRAINGER - DEPT 834637282	Revenue Fund	VO809629	216.84	SAFETY & MEDICAL SUPPLIES	JJENKINS	RRV00350031	7/26/2024	216.84
		Check RRV00350031:	216.84					
		<b>Total for GRAINGER - DEPT 834637282:</b>	<b>354.43</b>					
GRAINGER - DEPT 855818209	Revenue Fund	VO807728	119.52	SAFETY & MEDICAL SUPPLIES	RROWEN	RRV00349331	7/5/2024	119.52
		Check RRV00349331:	119.52					
		<b>Total for GRAINGER - DEPT 855818209:</b>	<b>119.52</b>					
GRAND RENTAL STATION - GROVE	Revenue Fund	VO809634	90.00	EQUIPMENT RENTAL	DCRAIG	RRV00350032	7/26/2024	90.00
		Check RRV00350032:	90.00					
		<b>Total for GRAND RENTAL STATION - GROVE:</b>	<b>90.00</b>					
GRANT COUNTY TAG AGENCY	Revenue Fund	VO808148	20.00	FEE/ISSUANCE 8 PIKEPASS 06/2024	APERINGO	RRV00349468	7/10/2024	20.00
		Check RRV00349468:	20.00					
		<b>Total for GRANT COUNTY TAG AGENCY:</b>	<b>20.00</b>					
GREAT WESTERN TRAILER	Revenue Fund	VO810121	42.40	EQUIPMENT PARTS & SUPPLIES	DCRAIG	RRV00350134	7/31/2024	42.40
		Check RRV00350134:	42.40					
		<b>Total for GREAT WESTERN TRAILER:</b>	<b>42.40</b>					
GREEN'S PROPANE	Revenue Fund	VO809637	231.57	NATURAL & PROPANE GAS	RDTAYLOR	RRV00350033	7/26/2024	231.57
		Check RRV00350033:	231.57					
		<b>Total for GREEN'S PROPANE:</b>	<b>231.57</b>					
GREENWAY PLAZA TAG AGENCY	Revenue Fund	VO808149	237.50	FEE/ISSUANCE 95 PIKEPASS 06/2024	APERINGO	RRV00349469	7/10/2024	237.50
		Check RRV00349469:	237.50					
		<b>Total for GREENWAY PLAZA TAG AGENCY:</b>	<b>237.50</b>					
GRIFFIN TELEVISION TULSA, KOTV	Revenue Fund	VO809421	1,500.00	ADVERTISING & MARKETING	LSALIM	RRV00349960	7/25/2024	8,500.00
		VO809422	1,000.00	ADVERTISING & MARKETING				
		VO809416	6,000.00	ADVERTISING & MARKETING				
		Check RRV00349960:	8,500.00					
		<b>Total for GRIFFIN TELEVISION TULSA, KOTV:</b>	<b>8,500.00</b>					
GRIMSLEYS INC	Revenue Fund	VO807735	244.22	CLEANING & OTHER SUPPLIES	RROWEN	RRV00349321	7/5/2024	244.22
		Check RRV00349321:	244.22					
GRIMSLEYS INC	Revenue Fund	VO809050	311.09	CLEANING & JANITORIAL SUPPLIES	RROWEN	RRV00349880	7/19/2024	311.09
		Check RRV00349880:	311.09					
		<b>Total for GRIMSLEYS INC:</b>	<b>555.31</b>					
GROVE MUNICIPAL SERVICES AUTHC	Revenue Fund	VO808664	18.25	WATER SERVICE	BPATTERS	EFT018801	7/15/2024	18.25
		Check EFT018801:	18.25					
		<b>Total for GROVE MUNICIPAL SERVICES AUTHORITY:</b>	<b>18.25</b>					
GROVE TAG AGENCY - 2110	Revenue Fund	VO808150	155.00	FEE/ISSUANCE 62 PIKEPASS 06/2024	APERINGO	RRV00349470	7/10/2024	155.00
		Check RRV00349470:	155.00					
		<b>Total for GROVE TAG AGENCY - 2110:</b>	<b>155.00</b>					
GULF MATERIAL SALES, L.L.C.	Revenue Fund	VO809274	4,088.00	TRAFFIC CNTRL & SFTY SUPPLIES ; 25613	MCCOLLINS	REV00016063	7/22/2024	16,553.00
		VO809275	12,465.00	TRAFFIC CNTRL & SFTY SUPPLIES ; 25580				
		Check REV00016063:	16,553.00					

Vendor Name	Fund Desc	Voucher NO.	Amt Applied	Description	Approver	Check No.	Date Paid	Amt Check
GULF MATERIAL SALES, L.L.C.	Revenue Fund	VO807738	6,200.00	TRAFFIC CONTROL & SAFETY SUPPLIES	SALLEN	RRV00349322	7/5/2024	6,200.00
		Check RRV00349322:	6,200.00					
GULF MATERIAL SALES, L.L.C.	Revenue Fund	VO809055	175.00	SMALL TOOLS & EQUIPMENT	DCRAIG MCCOLLINS	RRV00349881	7/19/2024	4,525.00
		VO809065	4,350.00	TRAFFICE CONTROL & SAFETY SUPPLIES				
		Check RRV00349881:	4,525.00					
GULF MATERIAL SALES, L.L.C.	Revenue Fund	VO810127	1,200.00	TRAFFIC CONTROL & SAFETY SUPPLIES	MCCOLLINS	RRV00350135	7/31/2024	1,200.00
		Check RRV00350135:	1,200.00					
<b>Total for GULF MATERIAL SALES, L.L.C.:</b>			<b>28,478.00</b>					
GUTHRIE TAG AGENCY	Revenue Fund	VO808151	90.00	FEE/ISSUANCE 36 PIKEPASS 06/2024	APERINGO	RRV00349471	7/10/2024	90.00
		Check RRV00349471:	90.00					
<b>Total for GUTHRIE TAG AGENCY:</b>			<b>90.00</b>					
H I S PAINT MFG. CO. LLC	Revenue Fund	VO809563	301.90	PAINT SUPPLIES	RDTAYLOR	RRV00350009	7/25/2024	301.90
		Check RRV00350009:	301.90					
<b>Total for H I S PAINT MFG. CO. LLC:</b>			<b>301.90</b>					
H N T B	General	VO809688	3,920.40	GTC FUTURE TECH ; 009-70903-PL-004	DMA4TGAT	GEN00021523	7/26/2024	3,920.40
		Check GEN00021523:	3,920.40					
<b>Total for H N T B:</b>			<b>3,920.40</b>					
H.O.W. RUBBER, INC.	Revenue Fund	VO807753	70.50	EQUIPMENT PARTS & SUPPLIES	PGOGGIN	RRV00349329	7/5/2024	70.50
		Check RRV00349329:	70.50					
<b>Total for H.O.W. RUBBER, INC.:</b>			<b>70.50</b>					
H.W. LOCHNER, INC.	General	VO808815	30,293.82	WR-MC-139: CON ADM/RES ENG: 000023322-2	TJDILL TJDILL	GEN00021483	7/16/2024	42,428.08
		VO808816	12,134.26	WR-MC-139: CON AD/RES ENG: 000023322-1-R				
		Check GEN00021483:	42,428.08					
<b>Total for H.W. LOCHNER, INC.:</b>			<b>42,428.08</b>					
H2O DEPOT	Revenue Fund	VO807739	35.00	BOTTLED DRINKING WATER	KDERVIN	RRV00349323	7/5/2024	35.00
		Check RRV00349323:	35.00					
H2O DEPOT	Revenue Fund	VO809067	35.00	BOTTLED DRINKING WATER	KDERVIN	RRV00349882	7/19/2024	35.00
		Check RRV00349882:	35.00					
H2O DEPOT	Revenue Fund	VO809638	35.00	BOTTLED DRINKING WATER	KDERVIN	RRV00350034	7/26/2024	35.00
		Check RRV00350034:	35.00					
		<b>Total for H2O DEPOT:</b>						
HAC, INC.	Revenue Fund	VO807740	89.88	SAFETY & MEDICAL SUPPLIES	RROWEN	RRV00349324	7/5/2024	89.88
		Check RRV00349324:	89.88					
HAC, INC.	Revenue Fund	VO808445	55.17	EMPLOYEE INCENTIVE AWARDS - FOOD, CATER	RROWEN	RRV00349697	7/12/2024	55.17
		Check RRV00349697:	55.17					
		<b>Total for HAC, INC.:</b>						
HALFF ASSOCIATES, INC.	Reserve Maintenance	VO809335	3,375.00	T-MC-139, ENG DESGN SVC, FINAL INSPECT	TJD4JECH TJD4JECH	RMT00006052	7/23/2024	4,500.00
		VO809334	1,125.00	T-MC-139, ENG DESGN SVC, FINAL INSPECT				
		Check RMT00006052:	4,500.00					
<b>Total for HALFF ASSOCIATES, INC.:</b>			<b>4,500.00</b>					

Vendor Name	Fund Desc	Voucher NO.	Amt Applied	Description	Approver	Check No.	Date Paid	Amt Check
HARBOR FREIGHT TOOLS - MST5 TRF	Revenue Fund	VO809071	109.98	SMALL TOOLS & EQUIPMENT	PGOGGIN	RRV00349884	7/19/2024	109.98
		Check RRV00349884:	109.98					
<b>Total for HARBOR FREIGHT TOOLS - MST5 TREVIPAY:</b>			<b>109.98</b>					
HARD HAT SAFETY AND GLOVE, LLC	Revenue Fund	VO809084	276.00	SAFETY & MEDICAL SUPPLIES	RDTAYLOR	RRV00349883	7/19/2024	276.00
		Check RRV00349883:	276.00					
<b>Total for HARD HAT SAFETY AND GLOVE, LLC:</b>			<b>276.00</b>					
HARDEN, JEFFERY A	Revenue Fund	VO807450	226.80	EQUIPMENT REPAIR	DCRAIG	RRV00349192	7/2/2024	533.80
		VO807510	307.00	EQUIPMENT REPAIR	DCRAIG			
		Check RRV00349192:	533.80					
HARDEN, JEFFERY A	Revenue Fund	VO807370	539.00	BUILDING MAINTENANCE SERVICES	JJENKINS	RRV00349337	7/8/2024	1,526.60
		VO807369	400.40	BUILDING MAINTENANCE SERVICES	CHUGHES			
		VO807387	320.40	EQUIPMENT REPAIRS	CHUGHES			
		VO807371	266.80	BUILDING MAINTENANCE SERVICES	DCRAIG			
		Check RRV00349337:	1,526.60					
<b>Total for HARDEN, JEFFERY A:</b>			<b>2,060.40</b>					
HARLAN FORD, INC.	Revenue Fund	VO808153	82.50	FEE/ISSUANCE 33 PIKEPASS 06/2024	APERINGO	RRV00349472	7/10/2024	82.50
		Check RRV00349472:	82.50					
<b>Total for HARLAN FORD, INC.:</b>			<b>82.50</b>					
HARRAH TAG AGENCY - 5594	Revenue Fund	VO808154	77.50	FEE/ISSUANCE 31 PIKEPASS 06/2024	APERINGO	RRV00349473	7/10/2024	77.50
		Check RRV00349473:	77.50					
<b>Total for HARRAH TAG AGENCY - 5594:</b>			<b>77.50</b>					
HARRIS & HARRIS LTD	Revenue Fund	VO805596	15,331.41	COLLECTIONS - PPS, APRIL 2024 ; 67550	PWILLIAM	REV00016023	7/2/2024	104,749.30
		VO807610	89,417.89	COLLECTIONS-PLATEPAY MARCH 2024; 67279	PWILLIAM			
		Check REV00016023:	104,749.30					
<b>Total for HARRIS &amp; HARRIS LTD:</b>			<b>104,749.30</b>					
HARRISON TIRE & SUPPLY COMPAN\	Revenue Fund	VO807741	120.00	VEHICLE PARTS & REPAIRS	BCANTREL	RRV00349330	7/5/2024	135.00
		VO807742	15.00	EQUIPMENT REPAIRS	BCANTREL			
		Check RRV00349330:	135.00					
HARRISON TIRE & SUPPLY COMPAN\	Revenue Fund	VO809094	1,345.00	EQUIPMENT PARTS & SUPPLIES	MCOLLINS	RRV00349890	7/19/2024	1,345.00
		Check RRV00349890:	1,345.00					
<b>Total for HARRISON TIRE &amp; SUPPLY COMPANY:</b>			<b>1,480.00</b>					
HARTLEY LAW FIRM	General	VO809285	187.50	DFWD R/W LGL FEES/GILC-VAC (G-126): 6184	TGORE	GEN00021507	7/22/2024	3,674.60
		VO809288	300.00	DFWD R/W LGL FEES: G-18: 6185	TGORE			
		VO809289	300.00	DFWD R/W LGL FEES: G-195: 6186	TGORE			
		VO809291	500.00	EOC CNDMTN: E-522, T1: 6188	TGORE			
		VO809292	1,887.10	INVRSE LGL FEES: CJ-2023-2031: 6189	TGORE			
		VO809290	500.00	EOC CNDMTN: E-522, T2: : 6187	TGORE			
		Check GEN00021507:	3,674.60					
<b>Total for HARTLEY LAW FIRM:</b>			<b>3,674.60</b>					
HARTSHORNE TAG AGENCY-KELLY C	Revenue Fund	VO808155	15.00	FEE/ISSUANCE 6 PIKEPASS 06/2024	APERINGO	RRV00349474	7/10/2024	15.00
		Check RRV00349474:	15.00					
<b>Total for HARTSHORNE TAG AGENCY-KELLY COLBERT#6115:</b>			<b>15.00</b>					
HASKELL LEMON GROUP LLC	Reserve Maintenance	VO808264	3,076,615.95	HEB-MC-69B ; ESTIMATE NO. 3	TJD4JECH	RMT00006044	7/10/2024	3,076,615.95

Vendor Name	Fund Desc	Voucher NO.	Amt Applied	Description	Approver	Check No.	Date Paid	Amt Check
		Check RMT00006044:	3,076,615.95					
HASKELL LEMON GROUP LLC	Reserve Maintenance	VO808970	716,274.60	C-MC-34 ; ESTIMATE NO. 3	TJD4JECH	RMT00006049	7/17/2024	716,274.60
		Check RMT00006049:	716,274.60					
		<b>Total for HASKELL LEMON GROUP LLC:</b>	<b>3,792,890.55</b>					
HASKELL TAG AGENCY #5115	Revenue Fund	VO808157	35.00	FEE/ISSUANCE 14 PIKEPASS 06/2024	APERINGO	RRV00349475	7/10/2024	35.00
		Check RRV00349475:	35.00					
		<b>Total for HASKELL TAG AGENCY #5115:</b>	<b>35.00</b>					
HD SUPPLY INC -- FORMERLY HOME	Revenue Fund	VO807744	18.78	SIGNING SUPPLIES & HARDWARE	JJENKINS	RRV00349325	7/5/2024	269.46
		VO807747	250.68	ASPHALT & CONCRETE SUPPLIES	JJENKINS			
		Check RRV00349325:	269.46					
HD SUPPLY INC -- FORMERLY HOME	Revenue Fund	VO807353	186.70	ASPHALT & CONCRETE SUPPLIES	JJENKINS	RRV00349335	7/8/2024	234.67
		VO807356	-130.69	ASPHALT & CONCRETE SUPPLIES	JJENKINS			
		VO807342	126.72	SMALL TOOLS, OTHER MAINT, & CONCRETE SUP	JJENKINS			
		VO807349	51.94	SMALL TOOLS & CONCRETE SUPPLIES	JJENKINS			
		Check RRV00349335:	234.67					
HD SUPPLY INC -- FORMERLY HOME	Revenue Fund	VO809100	59.86	SMALL TOOLS & EQUIPMENT	JJENKINS	RRV00349885	7/19/2024	59.86
		Check RRV00349885:	59.86					
HD SUPPLY INC -- FORMERLY HOME	Revenue Fund	VO809647	31.68	SMALL TOOLS & BUILDING MAINT SUPPLIES	JJENKINS	RRV00350035	7/26/2024	92.33
		VO809648	11.80	EQUIPMENT PARTS & SUPPLIES	JJENKINS			
		VO809656	48.85	JANITORIAL & VEHICLE SUPPLIES	PGOGGIN			
		Check RRV00350035:	92.33					
		<b>Total for HD SUPPLY INC -- FORMERLY HOME DEPOT PRO:</b>	<b>656.32</b>					
HEALDTON TAG AGENCY	Revenue Fund	VO808167	17.50	FEE/ISSUANCE 7 PIKEPASS 06/2024	APERINGO	RRV00349476	7/10/2024	17.50
		Check RRV00349476:	17.50					
		<b>Total for HEALDTON TAG AGENCY:</b>	<b>17.50</b>					
HELENA CHEMICAL CO.	Revenue Fund	VO810009	16,731.00	INSECTICIDES & HERBICIDES ; 11795737	SALLEN	REV00016078	7/29/2024	16,731.00
		Check REV00016078:	16,731.00					
		<b>Total for HELENA CHEMICAL CO.:</b>	<b>16,731.00</b>					
HENNESSEY TAG AGENCY - 3708	Revenue Fund	VO808168	30.00	FEE/ISSUANCE 12 PIKEPASS 06/2024	APERINGO	RRV00349477	7/10/2024	30.00
		Check RRV00349477:	30.00					
		<b>Total for HENNESSEY TAG AGENCY - 3708:</b>	<b>30.00</b>					
HENRYETTA TAG OFF - ANGELA WILH	Revenue Fund	VO808169	32.50	FEE/ISSUANCE 13 PIKEPASS 06/2024	APERINGO	RRV00349478	7/10/2024	32.50
		Check RRV00349478:	32.50					
		<b>Total for HENRYETTA TAG OFF - ANGELA WILHITE 5609:</b>	<b>32.50</b>					
HERC RENTALS INC.	Revenue Fund	VO807748	1,030.00	EQUIPMENT RENTAL	SALLEN	RRV00349326	7/5/2024	1,030.00
		Check RRV00349326:	1,030.00					
HERC RENTALS INC.	Revenue Fund	VO808457	1,030.00	EQUIPMENT RENTAL	SALLEN	RRV00349698	7/12/2024	1,030.00
		Check RRV00349698:	1,030.00					
HERC RENTALS INC.	Revenue Fund	VO809651	970.56	EQUIPMENT RENTAL	RDTAYLOR	RRV00350036	7/26/2024	1,468.56
		VO809650	95.00	EQUIPMENT RENTAL	RDTAYLOR			
		VO809652	403.00	EQUIPMENT RENTAL	RDTAYLOR			

Vendor Name	Fund Desc	Voucher NO.	Amt Applied	Description	Approver	Check No.	Date Paid	Amt Check
		Check RRV00350036:	1,468.56					
		<b>Total for HERC RENTALS INC.:</b>	<b>3,528.56</b>					
HERITAGE PROFESSIONAL PRODUCT	Revenue Fund	VO807750	3,074.40	INSECTICIDES & HERBICIDES	SALLEN	RRV00349327	7/5/2024	3,074.40
		Check RRV00349327:	3,074.40					
HERITAGE PROFESSIONAL PRODUCT	Revenue Fund	VO809104	2,100.00	INSECTICIDES & HERBICIDES	MCOLLINS	RRV00349886	7/19/2024	2,100.00
		Check RRV00349886:	2,100.00					
HERITAGE PROFESSIONAL PRODUCT	Revenue Fund	VO809653	5,888.70	INSECTICIDES & HERBICIDES	SALLEN	RRV00350037	7/26/2024	5,888.70
		Check RRV00350037:	5,888.70					
		<b>Total for HERITAGE PROFESSIONAL PRODUCTS GROUP:</b>	<b>11,063.10</b>					
HILL TAG AGENCY-8809	Revenue Fund	VO808170	32.50	FEE/ISSUANCE 13 PIKEPASS 06/2024	APERINGO	RRV00349479	7/10/2024	32.50
		Check RRV00349479:	32.50					
		<b>Total for HILL TAG AGENCY-8809:</b>	<b>32.50</b>					
HILLTOP SECURITIES INC.	General	VO809019	10,000.00	FIN ADVSR RTNR: JUNE 24': INV# 109777	WSMITH	GEN00021494	7/17/2024	10,000.00
		Check GEN00021494:	10,000.00					
		<b>Total for HILLTOP SECURITIES INC.:</b>	<b>10,000.00</b>					
HINTON TAG AGENCY	Revenue Fund	VO808171	15.00	FEE/ISSUANCE 6 PIKEPASS 06/2024	APERINGO	RRV00349480	7/10/2024	15.00
		Check RRV00349480:	15.00					
		<b>Total for HINTON TAG AGENCY:</b>	<b>15.00</b>					
HOBART TAG AGENCY	Revenue Fund	VO808172	5.00	FEE/ISSUANCE 2 PIKEPASS 06/2024	APERINGO	RRV00349481	7/10/2024	5.00
		Check RRV00349481:	5.00					
		<b>Total for HOBART TAG AGENCY:</b>	<b>5.00</b>					
HOLDENVILLE TAG AGENCY	Revenue Fund	VO808174	25.00	FEE/ISSUANCE 10 PIKEPASS 06/2024	APERINGO	RRV00349483	7/10/2024	25.00
		Check RRV00349483:	25.00					
		<b>Total for HOLDENVILLE TAG AGENCY:</b>	<b>25.00</b>					
HOLT TRUCK CENTERS	Revenue Fund	VO809107	349.95	VEHICLE PARTS & SUPPLIES	KWALLIS	RRV00349887	7/19/2024	349.95
		Check RRV00349887:	349.95					
		<b>Total for HOLT TRUCK CENTERS:</b>	<b>349.95</b>					
HOLT TRUCK CENTERS OF OKLAHOM	Revenue Fund	VO808175	22.50	FEE/ISSUANCE 9 PIKEPASS 06/2024	APERINGO	RRV00349484	7/10/2024	22.50
		Check RRV00349484:	22.50					
		<b>Total for HOLT TRUCK CENTERS OF OKLAHOMA, LLC:</b>	<b>22.50</b>					
HOLYBEE, CHARLES	Revenue Fund	VO808817	117.52	JULY 2024 EXPENSES	KWALLIS	RRV00349908	7/23/2024	117.52
		Check RRV00349908:	117.52					
		<b>Total for HOLYBEE, CHARLES:</b>	<b>117.52</b>					
HOME DEPOT PRO EIN#52-2418852	Revenue Fund	VO807932	108.36	SMALL TOOL, SAFETY & CLEANING SUPPLIES	JJENKINS	RRV00349336	7/8/2024	108.36
		Check RRV00349336:	108.36					
		<b>Total for HOME DEPOT PRO EIN#52-2418852:</b>	<b>108.36</b>					
HOMETOWN BOTTLED WATER-COFF	Revenue Fund	VO807751	56.00	BOTTLED DRINKING WATER	DCRAIG	RRV00349328	7/5/2024	56.00
		Check RRV00349328:	56.00					
HOMETOWN BOTTLED WATER-COFF	Revenue Fund	VO807003	16.00	BOTTLED DRINKING WATER	KINMAN	RRV00349370	7/8/2024	160.00
		VO807004	40.00	BOTTLED DRINKING WATER	KINMAN			

Vendor Name	Fund Desc	Voucher NO.	Amt Applied	Description	Approver	Check No.	Date Paid	Amt Check
		VO807005	40.00	BOTTLED DRINKING WATER	KINMAN			
		VO807008	48.00	BOTTLED DRINKING WATER	KINMAN			
		VO807647	16.00	CORRECTED-BOTTLED WATER	KINMAN			
		Check RRV00349370:	160.00					
HOMETOWN BOTTLED WATER-COFF Revenue Fund		VO808460	108.00	EQUIPMENT RENTAL	CHUGHES	RRV00349699	7/12/2024	108.00
		Check RRV00349699:	108.00					
HOMETOWN BOTTLED WATER-COFF Revenue Fund		VO809111	40.00	BOTTLED DRINKING WATER	CHUGHES	RRV00349888	7/19/2024	92.00
		VO809115	32.00	BOTTLED DRINKING WATER	DCRAIG			
		VO809113	20.00	EQUIPMENT RENTAL	DCRAIG			
		Check RRV00349888:	92.00					
HOMETOWN BOTTLED WATER-COFF Revenue Fund		VO809669	8.00	BOTTLED DRINKING WATER	KINMAN	RRV00350038	7/26/2024	296.00
		VO809675	16.00	BOTTLED DRINKING WATER	KINMAN			
		VO809660	8.00	BOTTLED DRINKING WATER	KINMAN			
		VO809679	8.00	BOTTLED DRINKING WATER	KINMAN			
		VO809664	32.00	BOTTLED DRINKING WATER	KINMAN			
		VO809666	40.00	BOTTLED DRINKING WATER	KINMAN			
		VO809667	32.00	BOTTLED DRINKING WATER	KINMAN			
		VO809668	40.00	BOTTLED DRINKING WATER	KINMAN			
		VO809676	32.00	BOTTLED DRINKING WATER	KINMAN			
		VO809677	40.00	BOTTLED DRINKING WATER	KINMAN			
		VO809678	40.00	BOTTLED DRINKING WATER	KINMAN			
		Check RRV00350038:	296.00					
<b>Total for HOMETOWN BOTTLED WATER-COFFEE (LLC):</b>			<b>712.00</b>					
HOMETOWN GROCERY	Revenue Fund	VO807971	74.71	SAFETY & MEDICAL SUPPLIES	KWALLIS	RRV00349376	7/8/2024	74.71
		Check RRV00349376:	74.71					
HOMETOWN GROCERY	Revenue Fund	VO808694	113.05	EMPLOYEE INCENTIVE - FOOD/CATERING	KWALLIS	RRV00349793	7/17/2024	113.05
		Check RRV00349793:	113.05					
HOMETOWN GROCERY	Revenue Fund	VO809866	49.52	SAFETY & MEDICAL SUPPLIES	KWALLIS	RRV00350049	7/29/2024	49.52
		Check RRV00350049:	49.52					
<b>Total for HOMETOWN GROCERY:</b>			<b>237.28</b>					
HONDA OF MUSKOGEE	Revenue Fund	VO808176	27.50	FEE/ISSUANCE 11 PIKEPASS 06/2024	APERINGO	RRV00349485	7/10/2024	27.50
		Check RRV00349485:	27.50					
<b>Total for HONDA OF MUSKOGEE:</b>			<b>27.50</b>					
HOUSE OF KAWASAKI	Revenue Fund	VO808177	5.00	FEE/ISSUANCE 2 PIKEPASS 06/2024	APERINGO	RRV00349482	7/10/2024	5.00
		Check RRV00349482:	5.00					
<b>Total for HOUSE OF KAWASAKI:</b>			<b>5.00</b>					
HUDSON PRINCE ENGINEERING & IN Capital Projects		VO809690	86,563.02	JKT-30705A: M3 RDWY DSGN: 2429-2	DBUTLER	23A0000244	7/26/2024	170,910.60
		VO809696	84,347.58	JKT-30705A: M3 RDWY DSGN: 2429-3	DBUTLER			
		Check 23A0000244:	170,910.60					
HUDSON PRINCE ENGINEERING & IN General		VO808203	43,140.11	C-MC-35: RES ENG/OSR/TSTNG: 23108-6	TJDILL	GEN00021462	7/10/2024	78,931.78
		VO808205	35,791.67	CHT-MC-11: RES ENG/OSR/TSTNG: 2355-13	TJDILL			
		Check GEN00021462:	78,931.78					
<b>Total for HUDSON PRINCE ENGINEERING &amp; INSPECTION:</b>			<b>249,842.38</b>					



Vendor Name	Fund Desc	Voucher NO.	Amt Applied	Description	Approver	Check No.	Date Paid	Amt Check
HUGO TAG OFFICE - CORRINA HEAD	Revenue Fund	VO808179	50.00	FEE/ISSUANCE 20 PIKEPASS 06/2024	APERINGO	RRV00349486	7/10/2024	50.00
		Check RRV00349486:	50.00					
		<b>Total for HUGO TAG OFFICE - CORRINA HEADY:</b>	<b>50.00</b>					
HUNTER MECHANICAL, INC.	Revenue Fund	VO809294	258.75	BUILDING MAINTENANCE SERVICES	TJDILL	RRV00349901	7/22/2024	546.25
		VO809296	287.50	BUILDING MAINTENANCE SERVICES	TJDILL			
		Check RRV00349901:	546.25					
		<b>Total for HUNTER MECHANICAL, INC.:</b>	<b>546.25</b>					
INCEED, L.L.C.	General	VO808301	2,320.00	OTHER PROFESSIONAL SVCS ; 709508	DMA4TGAT	GEN00021469	7/11/2024	109,794.32
		VO808303	2,800.00	OTHER PROFESSIONAL SVCS ; 709510	DMA4TGAT			
		VO808304	2,200.00	OTHER PROFESSIONAL SVCS ; 709511	DMA4TGAT			
		VO808305	3,040.00	OTHER PROFESSIONAL SVCS ; 709512	DMA4TGAT			
		VO808306	2,640.00	OTHER PROFESSIONAL SVCS ; 709513	DMA4TGAT			
		VO808321	2,320.00	OTHER PROFESSIONAL SVCS ; 709538	DMA4TGAT			
		VO808337	2,800.00	OTHER PROFESSIONAL SVCS ; 709871	DMA4TGAT			
		VO808345	1,600.00	OTHER PROFESSIONAL SVCS ; 709875	DMA4TGAT			
		VO808350	4,080.00	OTHER PROFESSIONAL SVCS ; 709877	DMA4TGAT			
		VO808351	2,720.00	OTHER PROFESSIONAL SVCS ; 709879	DMA4TGAT			
		VO808353	1,914.00	OTHER PROFESSIONAL SVCS ; 709966	DMA4TGAT			
		VO808379	2,200.00	OTHER PROFESSIONAL SVCS ; 709969	DMA4TGAT			
		VO808408	2,320.00	OTHER PROFESSIONAL SVCS ; 710183	DMA4TGAT			
		VO808414	3,040.00	OTHER PROFESSIONAL SVCS ; 710187	DMA4TGAT			
		VO808417	2,880.00	OTHER PROFESSIONAL SVCS ; 710191	DMA4TGAT			
		VO808420	2,320.00	OTHER PROFESSIONAL SVCS ; 710194	DMA4TGAT			
		VO808423	4,080.00	OTHER PROFESSIONAL SVCS ; 710199	DMA4TGAT			
		VO808424	2,720.00	OTHER PROFESSIONAL SVCS ; 710201	DMA4TGAT			
		VO808302	1,840.00	OTHER PROFESSIONAL SVCS ; 709509	DMA4TGAT			
		VO808307	1,600.00	OTHER PROFESSIONAL SVCS ; 709541	DMA4TGAT			
		VO808310	2,880.00	OTHER PROFESSIONAL SVCS ; 709516	DMA4TGAT			
		VO808324	2,214.40	OTHER PROFESSIONAL SVCS ; 709539	DMA4TGAT			
		VO808340	2,320.00	OTHER PROFESSIONAL SVCS ; 709872	DMA4TGAT			
		VO808348	3,334.40	OTHER PROFESSIONAL SVCS ; 709876	DMA4TGAT			
		VO808357	1,840.00	OTHER PROFESSIONAL SVCS ; 709967	DMA4TGAT			
		VO808381	3,040.00	OTHER PROFESSIONAL SVCS ; 709970	DMA4TGAT			
		VO808406	1,600.00	OTHER PROFESSIONAL SVCS ; 710197	DMA4TGAT			
		VO808412	2,200.00	OTHER PROFESSIONAL SVCS ; 710186	DMA4TGAT			
		VO808419	2,800.00	OTHER PROFESSIONAL SVCS ; 710193	DMA4TGAT			
		VO808421	2,048.32	OTHER PROFESSIONAL SVCS ; 710196	DMA4TGAT			
		VO808317	2,800.00	OTHER PROFESSIONAL SVCS ; 709518	DMA4TGAT			
		VO808328	3,334.40	OTHER PROFESSIONAL SVCS ; 709542	DMA4TGAT			
		VO808330	4,080.00	OTHER PROFESSIONAL SVCS ; 709543	DMA4TGAT			
		VO808332	2,720.00	OTHER PROFESSIONAL SVCS ; 709545	DMA4TGAT			
		VO808335	2,880.00	OTHER PROFESSIONAL SVCS ; 709869	DMA4TGAT			
		VO808342	2,214.40	OTHER PROFESSIONAL SVCS ; 709874	DMA4TGAT			
		VO808377	2,800.00	OTHER PROFESSIONAL SVCS ; 709968	DMA4TGAT			
		VO808383	2,640.00	OTHER PROFESSIONAL SVCS ; 709971	DMA4TGAT			
		VO808409	1,840.00	OTHER PROFESSIONAL SVCS ; 710184	DMA4TGAT			
		VO808410	2,800.00	OTHER PROFESSIONAL SVCS ; 710185	DMA4TGAT			
		VO808416	2,640.00	OTHER PROFESSIONAL SVCS ; 710188	DMA4TGAT			
		VO808422	3,334.40	OTHER PROFESSIONAL SVCS ; 710198	DMA4TGAT			
		Check GEN00021469:	109,794.32					
INCEED, L.L.C.	General	VO809346	1,920.00	OTHER PROFESSIONAL SVCS ; 710559	ABOULDEN	GEN00021510	7/24/2024	41,965.80

Vendor Name	Fund Desc	Voucher NO.	Amt Applied	Description	Approver	Check No.	Date Paid	Amt Check
		VO809396	2,320.00	OTHER PROFESSIONAL SVCS ; 710547	DMA4TGAT			
		VO809398	2,800.00	OTHER PROFESSIONAL SVCS ; 710549	DMA4TGAT			
		VO809402	2,112.00	OTHER PROFESSIONAL SVCS ; 710552	DMA4TGAT			
		VO809403	2,880.00	OTHER PROFESSIONAL SVCS ; 710555	DMA4TGAT			
		VO809405	2,320.00	OTHER PROFESSIONAL SVCS ; 710558	DMA4TGAT			
		VO809406	2,214.40	OTHER PROFESSIONAL SVCS ; 710560	DMA4TGAT			
		VO809344	1,920.00	OTHER PROFESSIONAL SVCS ; 709873	ABOULDEN			
		VO809397	1,840.00	OTHER PROFESSIONAL SVCS ; 710548	DMA4TGAT			
		VO809399	2,145.00	OTHER PROFESSIONAL SVCS ; 710550	DMA4TGAT			
		VO809401	3,040.00	OTHER PROFESSIONAL SVCS ; 710551	DMA4TGAT			
		VO809408	3,334.40	OTHER PROFESSIONAL SVCS ; 710562	DMA4TGAT			
		VO809409	4,080.00	OTHER PROFESSIONAL SVCS ; 710563	DMA4TGAT			
		VO809345	1,920.00	OTHER PROFESSIONAL SVCS ; 710195	ABOULDEN			
		VO809404	2,800.00	OTHER PROFESSIONAL SVCS ; 710557	DMA4TGAT			
		VO809407	1,600.00	OTHER PROFESSIONAL SVCS ; 710561	DMA4TGAT			
		VO809411	2,720.00	OTHER PROFESSIONAL SVCS ; 710565	DMA4TGAT			
		Check GEN00021510:	41,965.80					
INCEED, L.L.C.	General	VO809699	1,771.52	OTHER PROFESSIONAL SVCS ; 710953	DMA4TGAT	GEN00021524	7/26/2024	28,353.92
		VO809692	1,840.00	OTHER PROFESSIONAL SVCS ; 710943	DMA4TGAT			
		VO809697	2,240.00	OTHER PROFESSIONAL SVCS ; 710950	DMA4TGAT			
		VO809700	1,600.00	OTHER PROFESSIONAL SVCS ; 710954	DMA4TGAT			
		VO809701	3,334.40	OTHER PROFESSIONAL SVCS ; 710955	DMA4TGAT			
		VO809702	3,264.00	OTHER PROFESSIONAL SVCS ; 710956	DMA4TGAT			
		VO809703	2,176.00	OTHER PROFESSIONAL SVCS ; 710958	DMA4TGAT			
		VO809689	1,536.00	OTHER PROFESSIONAL SVCS ; 710952	ABOULDEN			
		VO809691	2,320.00	OTHER PROFESSIONAL SVCS ; 710942	DMA4TGAT			
		VO809693	2,800.00	OTHER PROFESSIONAL SVCS ; 710944	DMA4TGAT			
		VO809694	3,040.00	OTHER PROFESSIONAL SVCS ; 710945	DMA4TGAT			
		VO809695	576.00	OTHER PROFESSIONAL SVCS ; 710948	DMA4TGAT			
		VO809698	1,856.00	OTHER PROFESSIONAL SVCS ; 710951	DMA4TGAT			
		Check GEN00021524:	28,353.92					
INCEED, L.L.C.	Revenue Fund	VO808976	2,560.00	OTHER PROFESSIONAL SVCS ; 709514	JECHELLE	REV00016047	7/17/2024	55,376.06
		VO808982	3,793.20	OTHER PROFESSIONAL SVCS ; 709544	DMA4TGAT			
		VO808985	3,969.20	OTHER PROFESSIONAL SVCS ; 709868	DMA4TGAT			
		VO808986	3,488.00	OTHER PROFESSIONAL SVCS ; 709870	DMA4TGAT			
		VO808994	2,496.00	OTHER PROFESSIONAL SVCS ; 710553	JECHELLE			
		VO808995	3,969.20	OTHER PROFESSIONAL SVCS ; 710554	DMA4TGAT			
		VO808996	3,488.00	OTHER PROFESSIONAL SVCS ; 710556	DMA4TGAT			
		VO808998	3,793.20	OTHER PROFESSIONAL SVCS ; 710564	DMA4TGAT			
		VO808978	4,167.66	OTHER PROFESSIONAL SVCS ; 709515	DMA4TGAT			
		VO808979	3,488.00	OTHER PROFESSIONAL SVCS ; 709517	DMA4TGAT			
		VO808983	2,560.00	OTHER PROFESSIONAL SVCS ; 709867	JECHELLE			
		VO808987	3,793.20	OTHER PROFESSIONAL SVCS ; 709878	DMA4TGAT			
		VO808989	2,560.00	OTHER PROFESSIONAL SVCS ; 710189	JECHELLE			
		VO808991	3,969.20	OTHER PROFESSIONAL SVCS ; 710190	DMA4TGAT			
		VO808992	3,488.00	OTHER PROFESSIONAL SVCS ; 710192	DMA4TGAT			
		VO808993	3,793.20	OTHER PROFESSIONAL SVCS ; 710200	DMA4TGAT			
		Check REV00016047:	55,376.06					
INCEED, L.L.C.	Revenue Fund	VO809658	3,793.20	OTHER PROFESSIONAL SVCS ; 711303	DMA4TGAT	REV00016071	7/26/2024	14,207.32
		VO809654	2,560.00	OTHER PROFESSIONAL SVCS ; 711286	JECHELLE			
		VO809655	4,366.12	OTHER PROFESSIONAL SVCS ; 711287	DMA4TGAT			

Vendor Name	Fund Desc	Voucher NO.	Amt Applied	Description	Approver	Check No.	Date Paid	Amt Check
		VO809657	3,488.00	OTHER PROFESSIONAL SVCS ; 711292	DMA4TGAT			
		Check REV00016071:	14,207.32					
INCEED, L.L.C.	Revenue Fund	VO809121	2,790.40	OTHER PROFESSIONAL SERVICES	PCAESAR	RRV00349889	7/19/2024	10,766.48
		VO809117	2,560.00	OTHER PROFESSIONAL SERVICES - IT	ABOULDEN			
		VO809119	2,381.52	OTHER PROFESSIONAL SERVICES	PCAESAR			
		VO809123	3,034.56	OTHER PROFESSIONAL SERVICES	PCAESAR			
		Check RRV00349889:	10,766.48					
		<b>Total for INCEED, L.L.C.:</b>	<b>260,463.90</b>					
INDIAN ELECTRIC COOP, INC	Revenue Fund	VO808669	2,069.61	ELECTRIC	BPATTERS	EFT018802	7/15/2024	2,069.61
		Check EFT018802:	2,069.61					
		<b>Total for INDIAN ELECTRIC COOP, INC:</b>	<b>2,069.61</b>					
INDIAN MOTORCYCLE OF OKC- RD M	Revenue Fund	VO808296	10.00	FEE/ISSUANCE 4 PIKEPASS 06/2024	APERINGO	RRV00349583	7/11/2024	10.00
		Check RRV00349583:	10.00					
		<b>Total for INDIAN MOTORCYCLE OF OKC- RD MOTORSPORTS:</b>	<b>10.00</b>					
INDIAN SPRINGS TAG AGENCY	Revenue Fund	VO808180	375.00	FEE/ISSUANCE 150 PIKEPASS 06/2024	APERINGO	RRV00349487	7/10/2024	375.00
		Check RRV00349487:	375.00					
		<b>Total for INDIAN SPRINGS TAG AGENCY:</b>	<b>375.00</b>					
INHOFE TAG AGENCY	Revenue Fund	VO808181	90.00	FEE/ISSUANCE 36 PIKEPASS 06/2024	APERINGO	RRV00349488	7/10/2024	90.00
		Check RRV00349488:	90.00					
		<b>Total for INHOFE TAG AGENCY:</b>	<b>90.00</b>					
INMAN, KAREN	Revenue Fund	VO807625	62.85	JULY 2024 EXPENSES	JMELTON	RRV00349231	7/2/2024	62.85
		Check RRV00349231:	62.85					
INMAN, KAREN	Revenue Fund	VO808044	105.85	JULY 2024 EXPENSES	JMELTON	RRV00349387	7/9/2024	105.85
		Check RRV00349387:	105.85					
INMAN, KAREN	Revenue Fund	VO808821	5.44	JULY 2024 EXPENSES	JMELTON	RRV00349754	7/16/2024	5.44
		Check RRV00349754:	5.44					
INMAN, KAREN	Revenue Fund	VO809354	39.74	JULY 2024 EXPENSES	JMELTON	RRV00349914	7/23/2024	39.74
		Check RRV00349914:	39.74					
		<b>Total for INMAN, KAREN:</b>	<b>213.88</b>					
INNOFIN SOLUTIONS LLC	General	VO809704	24,240.00	OTHER PROFESSIONAL SVCS ; INV-10535	ABOULDEN	GEN00021525	7/26/2024	24,240.00
		Check GEN00021525:	24,240.00					
		<b>Total for INNOFIN SOLUTIONS LLC:</b>	<b>24,240.00</b>					
INTEGRATED AV LLC	Revenue Fund	VO808468	600.00	OTHER CONTRACTUAL SERVICES	ABOULDEN	RRV00349700	7/12/2024	1,900.00
		VO808470	500.00	OTHER CONTRACTUAL SERVICES	ABOULDEN			
		VO808472	800.00	OTHER CONTRACTUAL SERVICES	ABOULDEN			
		Check RRV00349700:	1,900.00					
		<b>Total for INTEGRATED AV LLC:</b>	<b>1,900.00</b>					
JACKSON ELECTRICAL CONSTRUCTIO	General	VO809888	6,943.81	RDWY LGHT RPAIRS;/MTRL: KICKAPOO: 314787	JSMITH	GEN00021531	7/29/2024	26,474.91
		VO809887	9,163.33	RDWY LGHT RPAIRS;/MTRL: TURNER: 314809	JSMITH			
		VO809889	7,937.77	RDWY LGHT RPAIRS;/MTRL: KICKAPOO: 314804	JSMITH			
		VO809890	2,430.00	RDWY LGHT RPAIRS;/MTRL: TURNER: 314813	JSMITH			
		Check GEN00021531:	26,474.91					

Vendor Name	Fund Desc	Voucher NO.	Amt Applied	Description	Approver	Check No.	Date Paid	Amt Check
JACKSON ELECTRICAL CONSTRUCTION	Revenue Fund	VO807449	<u>660.00</u>	EQUIPMENT REPAIR	RDTAYLOR	RRV00349191	7/2/2024	660.00
		Check RRV00349191:	<u>660.00</u>					
		<b>Total for JACKSON ELECTRICAL CONSTRUCTION LLC:</b>	<b>27,134.91</b>					
JACKSONS OF KINGFISHER LLC	Revenue Fund	VO808182	<u>35.00</u>	FEE/ISSUANCE 14 PIKEPASS 06/2024	APERINGO	RRV00349489	7/10/2024	35.00
		Check RRV00349489:	<u>35.00</u>					
		<b>Total for JACKSONS OF KINGFISHER LLC:</b>	<b>35.00</b>					
JAMES SUPPLIES & RENTAL COMPANY	Revenue Fund	VO808704	<u>688.00</u>	EQUIPMENT RENTAL	BELLIS	RRV00349831	7/18/2024	694.30
		VO808706	<u>6.30</u>	EQUIPMENT RENTAL	BELLIS			
		Check RRV00349831:	<u>694.30</u>					
		<b>Total for JAMES SUPPLIES &amp; RENTAL COMPANY:</b>	<b>694.30</b>					
JANI-KING - TULSA REGION	Revenue Fund	VO808474	<u>620.00</u>	CUSTODIAL SERVICES	AHEITZ	RRV00349701	7/12/2024	620.00
		Check RRV00349701:	<u>620.00</u>					
		<b>Total for JANI-KING - TULSA REGION:</b>	<b>620.00</b>					
JARED AUTO PARTS	Revenue Fund	VO809293	<u>9.68</u>	EQUIPMENT PARTS AND SUPPLIES	KWALLIS	RRV00349961	7/25/2024	37.43
		VO809295	<u>27.75</u>	EQUIPMENT PARTS AND SUPPLIES	KWALLIS			
		Check RRV00349961:	<u>37.43</u>					
		<b>Total for JARED AUTO PARTS:</b>	<b>37.43</b>					
JAY HODGE DCJ R LLC	Revenue Fund	VO808183	<u>20.00</u>	FEE/ISSUANCE 8 PIKEPASS 06/2024	APERINGO	RRV00349490	7/10/2024	20.00
		Check RRV00349490:	<u>20.00</u>					
		<b>Total for JAY HODGE DCJ R LLC:</b>	<b>20.00</b>					
JAY TAG AGENCY - 2111	Revenue Fund	VO808187	<u>52.50</u>	FEE/ISSUANCE 21 PIKEPASS 06/2024	APERINGO	RRV00349491	7/10/2024	52.50
		Check RRV00349491:	<u>52.50</u>					
		<b>Total for JAY TAG AGENCY - 2111:</b>	<b>52.50</b>					
JENKS PUBLIC WORKS AUTHORITY	Revenue Fund	VO807730	<u>136.19</u>	WATER	BPATTERS	EFT018767	7/5/2024	136.19
		Check EFT018767:	<u>136.19</u>					
		<b>Total for JENKS PUBLIC WORKS AUTHORITY:</b>	<b>136.19</b>					
JENKS TAG AGENCY - 7276	Revenue Fund	VO808189	<u>577.50</u>	FEE/ISSUANCE 231 PIKEPASS 06/2024	APERINGO	RRV00349492	7/10/2024	577.50
		Check RRV00349492:	<u>577.50</u>					
		<b>Total for JENKS TAG AGENCY - 7276:</b>	<b>577.50</b>					
JIMS PEST CONTROL	Revenue Fund	VO809298	<u>75.00</u>	PEST CONTROL SERVICES	KINMAN	RRV00349962	7/25/2024	75.00
		Check RRV00349962:	<u>75.00</u>					
		<b>Total for JIMS PEST CONTROL:</b>	<b>75.00</b>					
JOHN COATS	Revenue Fund	VO807622	<u>56.50</u>	JULY 2024 EXPENSES	DCRAIG	RRV00349230	7/2/2024	56.50
		Check RRV00349230:	<u>56.50</u>					
		<b>Total for JOHN COATS:</b>	<b>56.50</b>					
JOHNNYS CAR CARE	Revenue Fund	VO807459	<u>20.00</u>	EQUIPMENT REPAIR	KWALLIS	RRV00349193	7/2/2024	60.00
		VO807458	<u>40.00</u>	EQUIPMENT REPAIR	KWALLIS			
		Check RRV00349193:	<u>60.00</u>					
JOHNNYS CAR CARE	Revenue Fund	VO808477	<u>268.32</u>	EQUIPMENT PARTS & REPAIRS	KWALLIS	RRV00349702	7/12/2024	268.32
		Check RRV00349702:	<u>268.32</u>					
		<b>Total for JOHNNYS CAR CARE:</b>	<b>328.32</b>					

Vendor Name	Fund Desc	Voucher NO.	Amt Applied	Description	Approver	Check No.	Date Paid	Amt Check
JOHNSON CONTROLS SECURITY SOLUTIONS	Revenue Fund	VO808482	1,359.75	ALARM MONITORING SERVICES	SALLEN	RRV00349703	7/12/2024	1,359.75
		Check RRV00349703:	1,359.75					
<b>Total for JOHNSON CONTROLS SECURITY SOLUTIONS:</b>			<b>1,359.75</b>					
JONES PUBLIC RELATIONS GROUP	General	VO807630	40,135.71	PR: ODOT SAFTY CMPGN: INV# 2024-5-21	LSALIM	GEN00021438	7/2/2024	40,135.71
		Check GEN00021438:	40,135.71					
JONES PUBLIC RELATIONS GROUP	General	VO808193	7,693.00	PR: OTA ACCESS: INV# 2024-6-25	LSALIM	GEN00021461	7/10/2024	10,704.10
		VO808185	2,104.60	PR: ODOT SAFTY CMPGN: INV# 2024-6-18	LSALIM			
		VO808188	906.50	PR: CASHLESS CNVRSN: INV# 2024-6-23	LSALIM			
		Check GEN00021461:	10,704.10					
JONES PUBLIC RELATIONS GROUP	Revenue Fund	VO808744	1,382.00	OTHER PROFESSIONAL SERVICES	LSALIM	RRV00349832	7/18/2024	7,161.60
		VO808731	661.50	OTHER PROFESSIONAL SERVICES	LSALIM			
		VO808741	4,971.10	OTHER PROFESSIONAL SERVICES	LSALIM			
		VO808745	147.00	OTHER PROFESSIONAL SERVICES	LSALIM			
		Check RRV00349832:	7,161.60					
<b>Total for JONES PUBLIC RELATIONS GROUP:</b>			<b>58,001.41</b>					
JONES TAG AGENCY - #5575	Revenue Fund	VO808190	45.00	FEE/ISSUANCE 18 PIKEPASS 06/2024	APERINGO	RRV00349493	7/10/2024	45.00
		Check RRV00349493:	45.00					
<b>Total for JONES TAG AGENCY - #5575:</b>			<b>45.00</b>					
JOSHUA'S AUTO SALES INC.	Revenue Fund	VO808191	10.00	FEE/ISSUANCE 4 PIKEPASS 06/2024	APERINGO	RRV00349494	7/10/2024	10.00
		Check RRV00349494:	10.00					
<b>Total for JOSHUA'S AUTO SALES INC.:</b>			<b>10.00</b>					
K & P EQUIPMENT	Revenue Fund	VO807600	1,187.76	EQUIPMENT PARTS AND SUPPLIES	SALLEN	RRV00349195	7/2/2024	1,352.06
		VO807601	164.30	EQUIPMENT PARTS; HARDWARE	RDTAYLOR			
		Check RRV00349195:	1,352.06					
K & P EQUIPMENT	Revenue Fund	VO807603	42.88	EQUIPMENT PARTS AND SUPPLIES	JSMART	RRV00349196	7/2/2024	73.10
		VO807602	30.22	EQUIPMENT PARTS AND SUPPLIES	JSMART			
		Check RRV00349196:	73.10					
K & P EQUIPMENT	Revenue Fund	VO808108	112.40	EQUIPMENT PARTS AND SUPPLIES	JSMART	RRV00349391	7/9/2024	414.86
		VO808107	302.46	EQUIPMENT PARTS AND SUPPLIES	JSMART			
		Check RRV00349391:	414.86					
K & P EQUIPMENT	Revenue Fund	VO809088	430.78	EQUIPMENT PARTS AND SUPPLIES	JSMART	RRV00349855	7/18/2024	430.78
		Check RRV00349855:	430.78					
K & P EQUIPMENT	Revenue Fund	VO809553	185.43	EQUIPMENT PARTS AND SUPPLIES	RDTAYLOR	RRV00349990	7/25/2024	404.82
		VO809557	219.39	EQUIPMENT PARTS AND SUPPLIES	RDTAYLOR			
		Check RRV00349990:	404.82					
K & P EQUIPMENT	Revenue Fund	VO809559	151.23	EQUIPMENT PARTS AND SUPPLIES	RDTAYLOR	RRV00349991	7/25/2024	1,160.32
		VO809560	923.26	EQUIPMENT PARTS AND SUPPLIES	JSMART			
		VO809562	85.83	EQUIPMENT PARTS AND SUPPLIES	RDTAYLOR			
		Check RRV00349991:	1,160.32					
K & P EQUIPMENT	Revenue Fund	VO810037	205.66	EQUIPMENT PARTS AND SUPPLIES	RDTAYLOR	RRV00350067	7/29/2024	205.66
		Check RRV00350067:	205.66					

Vendor Name	Fund Desc	Voucher NO.	Amt Applied	Description	Approver	Check No.	Date Paid	Amt Check
		<b>Total for K &amp; P EQUIPMENT:</b>	<b>4,041.60</b>					
KANSAS BUILDING SUPPLY, INC.	Revenue Fund	VO809300	85.34	ASPHALT SUPPLIES; OTHER COMMODITIES	CHUGHES	RRV00349965	7/25/2024	85.34
		Check RRV00349965:	85.34					
		<b>Total for KANSAS BUILDING SUPPLY, INC.:</b>	<b>85.34</b>					
KAREN L LONG	Revenue Fund	VO809646	20,245.00	LEGAL CONSULTATION SVCS ; 0001	JECHELLE	REV00016070	7/26/2024	20,245.00
		Check REV00016070:	20,245.00					
		<b>Total for KAREN L LONG:</b>	<b>20,245.00</b>					
KAY ELECTRIC COOP	Revenue Fund	VO807597	51.88	ELECTRIC	BPATTERS	EFT018749	7/2/2024	51.88
		Check EFT018749:	51.88					
		<b>Total for KAY ELECTRIC COOP:</b>	<b>51.88</b>					
KEETON, CHRISTI	Revenue Fund	VO807626	95.00	JULY 2024 EXPENSES	KWALLIS	RRV00349229	7/2/2024	95.00
		Check RRV00349229:	95.00					
KEETON, CHRISTI	Revenue Fund	VO809351	95.00	JULY 2024 EXPENSES	KWALLIS	RRV00349912	7/23/2024	95.00
		Check RRV00349912:	95.00					
		<b>Total for KEETON, CHRISTI:</b>	<b>190.00</b>					
KEITH HARDWARE & SUPPLY INC.	Revenue Fund	VO808483	41.99	INSECTICIDES & HERBICIDES	BCANTREL	RRV00349704	7/12/2024	41.99
		Check RRV00349704:	41.99					
		<b>Total for KEITH HARDWARE &amp; SUPPLY INC.:</b>	<b>41.99</b>					
KENNEDY LUMBER COMPANY, INC.	Revenue Fund	VO808749	36.97	PAINTING SUPPLIES	BELLIS	RRV00349833	7/18/2024	36.97
		Check RRV00349833:	36.97					
		<b>Total for KENNEDY LUMBER COMPANY, INC.:</b>	<b>36.97</b>					
KEYSTONE TRACTOR, LLC	Revenue Fund	VO808752	17.20	HARDWARE	KWALLIS	RRV00349834	7/18/2024	17.20
		Check RRV00349834:	17.20					
		<b>Total for KEYSTONE TRACTOR, LLC:</b>	<b>17.20</b>					
KIAMICHI ELECTRIC COOP	Revenue Fund	VO807478	511.00	ELECTRIC	BPATTERS	EFT018742	7/1/2024	511.00
		Check EFT018742:	511.00					
		<b>Total for KIAMICHI ELECTRIC COOP:</b>	<b>511.00</b>					
KIMS INTERNATIONAL	Revenue Fund	VO809301	41.92	EQUIPMENT PARTS AND SUPPLIES	JJENKINS	RRV00349963	7/25/2024	41.92
		Check RRV00349963:	41.92					
		<b>Total for KIMS INTERNATIONAL:</b>	<b>41.92</b>					
KINGSTON TAG AGENCY	Revenue Fund	VO808194	12.50	FEE/ISSUANCE 5 PIKEPASS 06/2024	APERINGO	RRV00349496	7/10/2024	12.50
		Check RRV00349496:	12.50					
		<b>Total for KINGSTON TAG AGENCY:</b>	<b>12.50</b>					
KINNUNEN SALES & RENTAL, INC.	Revenue Fund	VO807461	129.99	EQUIPMENT PARTS AND SUPPLIES	RROWEN	RRV00349194	7/2/2024	129.99
		Check RRV00349194:	129.99					
KINNUNEN SALES & RENTAL, INC.	Revenue Fund	VO808484	466.52	ASPHALT & CONCRETE SUPPLIES	RROWEN	RRV00349705	7/12/2024	508.50
		VO808485	41.98	ASPHALT & CONCRETE SUPPLIES	RROWEN			
		Check RRV00349705:	508.50					
KINNUNEN SALES & RENTAL, INC.	Revenue Fund	VO808840	143.80	ASPHALT & CONCRETE SUPPLIES	RROWEN	RRV00349835	7/18/2024	537.97
		VO808843	115.43	SAFETY & MEDICAL SUPPLIES	RROWEN			

Vendor Name	Fund Desc	Voucher NO.	Amt Applied	Description	Approver	Check No.	Date Paid	Amt Check
		VO808842	143.80	ASPHALT & CONCRETE SUPPLIES	RROWEN			
		VO808844	78.95	EQUIPMENT PARTS AND SUPPLIES	RROWEN			
		VO808838	55.99	SAFETY & MEDICAL SUPPLIES	RROWEN			
		Check RRV00349835:	537.97					
		<b>Total for KINNUNEN SALES &amp; RENTAL, INC.:</b>	<b>1,176.46</b>					
KIRBY SMITH MACHINERY, INC	Revenue Fund	VO808847	764.69	EQUIPMENT PARTS AND SUPPLIES	BELLIS	RRV00349836	7/18/2024	7,745.94
		VO808845	6,981.25	EQUIPMENT PARTS; HARDWARE	MCOLLINS			
		Check RRV00349836:	7,745.94					
		<b>Total for KIRBY SMITH MACHINERY, INC:</b>	<b>7,745.94</b>					
KOCO-TV	Revenue Fund	VO808756	3,000.00	ADVERTISING & MARKETING	LSALIM	RRV00349837	7/18/2024	10,000.00
		VO808763	5,000.00	ADVERTISING & MARKETING	LSALIM			
		VO808766	2,000.00	ADVERTISING & MARKETING	LSALIM			
		Check RRV00349837:	10,000.00					
		<b>Total for KOCO-TV:</b>	<b>10,000.00</b>					
KRAVE CAFE	Revenue Fund	VO808199	5.00	FEE/ISSUANCE 2 PIKEPASS 06/2024	APERINGO	RRV00349497	7/10/2024	5.00
		Check RRV00349497:	5.00					
		<b>Total for KRAVE CAFE:</b>	<b>5.00</b>					
KRONOS INCORPORATED	Revenue Fund	VO807470	1,492.61	ANNUAL SOFTWARE RENEWAL	MLOEFFEL	RRV00349197	7/2/2024	1,492.61
		Check RRV00349197:	1,492.61					
KRONOS INCORPORATED	Revenue Fund	VO809302	1,492.61	ANNUAL SOFTWARE RENEWAL	MLOEFFEL	RRV00349964	7/25/2024	1,492.61
		Check RRV00349964:	1,492.61					
		<b>Total for KRONOS INCORPORATED:</b>	<b>2,985.22</b>					
KWTV-TV	Revenue Fund	VO808770	5,500.00	ADVERTISING & MARKETING	LSALIM	RRV00349838	7/18/2024	7,000.00
		VO808771	1,500.00	ADVERTISING & MARKETING	LSALIM			
		Check RRV00349838:	7,000.00					
		<b>Total for KWTV-TV:</b>	<b>7,000.00</b>					
LAKE REGION ELECTRIC COOP	Revenue Fund	VO807592	924.97	ELECTRIC	BPATTERS	EFT018750	7/2/2024	924.97
		Check EFT018750:	924.97					
		<b>Total for LAKE REGION ELECTRIC COOP:</b>	<b>924.97</b>					
LANGSTON UNIVERSITY	Revenue Fund	VO808201	10.00	FEE/ISSUANCE 4 PIKEPASS 06/2024	APERINGO	RRV00349498	7/10/2024	10.00
		Check RRV00349498:	10.00					
		<b>Total for LANGSTON UNIVERSITY:</b>	<b>10.00</b>					
LANOY TAG AGENCY - 1436	Revenue Fund	VO808215	105.00	FEE/ISSUANCE 42 PIKEPASS 06/2024	APERINGO	RRV00349528	7/10/2024	105.00
		Check RRV00349528:	105.00					
		<b>Total for LANOY TAG AGENCY - 1436:</b>	<b>105.00</b>					
LATIMER COUNTY TAG AGENCY #390	Revenue Fund	VO808217	42.50	FEE/ISSUANCE 17 PIKEPASS 06/2024	APERINGO	RRV00349529	7/10/2024	42.50
		Check RRV00349529:	42.50					
		<b>Total for LATIMER COUNTY TAG AGENCY #3903:</b>	<b>42.50</b>					
LAW ENFORCEMENT SYSTEMS LLC	General	VO808695	492.36	VEH REQ PP LKUP-GILC: INV# 1014780-A	PWILLIAM	GEN00021476	7/15/2024	492.36
		Check GEN00021476:	492.36					
LAW ENFORCEMENT SYSTEMS LLC	Revenue Fund	VO808493	56,365.98	OTHER CNTRCTUAL SVCS, ROV ; 1014440	DMA4TGAT	REV00016030	7/12/2024	56,365.98
		Check REV00016030:	56,365.98					

Vendor Name	Fund Desc	Voucher NO.	Amt Applied	Description	Approver	Check No.	Date Paid	Amt Check
LAW ENFORCEMENT SYSTEMS LLC	Revenue Fund	VO809659	<u>37,402.20</u>	OTHER CNTRCTUAL SVCS, ROV ; 1014780	DMA4TGAT	REV00016072	7/26/2024	37,402.20
		Check REV00016072:	37,402.20					
LAW ENFORCEMENT SYSTEMS LLC	Revenue Fund	VO810017	<u>55,425.48</u>	OTHER CNTRCTUAL SVCS, ROV ; 1014166	DMA4TGAT	REV00016079	7/29/2024	55,425.48
		Check REV00016079:	55,425.48					
<b>Total for LAW ENFORCEMENT SYSTEMS LLC:</b>			<b>149,686.02</b>					
LAWTON - FORT SILL TAG AGENCY	Revenue Fund	VO808219	<u>480.00</u>	FEE/ISSUANCE 192 PIKEPASS 06/2024	APERINGO	RRV00349530	7/10/2024	480.00
		Check RRV00349530:	480.00					
<b>Total for LAWTON - FORT SILL TAG AGENCY:</b>			<b>480.00</b>					
LAWTON TRANSIT MIX, INC	Revenue Fund	VO807472	<u>2,347.50</u>	ASPHALT & CONCRETE SUPPLIES	SALLEN	RRV00349204	7/2/2024	2,347.50
		Check RRV00349204:	2,347.50					
LAWTON TRANSIT MIX, INC	Revenue Fund	VO807632	<u>1,471.50</u>	ASPHALT & CONCRETE SUPPLIES	SALLEN	RRV00349237	7/2/2024	1,471.50
		Check RRV00349237:	1,471.50					
<b>Total for LAWTON TRANSIT MIX, INC:</b>			<b>3,819.00</b>					
LEROY HAMES	Revenue Fund	VO807624	<u>81.50</u>	JULY 2024 EXPENSES	KWALLIS	RRV00349233	7/2/2024	81.50
		Check RRV00349233:	81.50					
<b>Total for LEROY HAMES:</b>			<b>81.50</b>					
LIBERTY UTILITY OKLAHOMA	Revenue Fund	VO807440	<u>22.94</u>	WATER	BPATTERS	EFT018732	7/1/2024	22.94
		Check EFT018732:	22.94					
LIBERTY UTILITY OKLAHOMA	Revenue Fund	VO808066	<u>69.97</u>	WATER	BPATTERS	EFT018784	7/9/2024	69.97
		Check EFT018784:	69.97					
<b>Total for LIBERTY UTILITY OKLAHOMA:</b>			<b>92.91</b>					
LINCOLN COUNTY FARM CENTER, IN	Revenue Fund	VO807494	<u>38.49</u>	SAFETY SUPPLIES; OTHER COMMODITIES	RDTAYLOR	RRV00349198	7/2/2024	112.84
		VO807496	<u>21.85</u>	SMALL TOOLS; OTHER COMMODITIES	RDTAYLOR			
		VO807499	<u>52.50</u>	EQUIPMENT PARTS; SMALL TOOLS	RDTAYLOR			
		Check RRV00349198:	112.84					
LINCOLN COUNTY FARM CENTER, IN	Revenue Fund	VO809305	<u>25.30</u>	SMALL TOOLS AND EQUIPMENT	RDTAYLOR	RRV00349967	7/25/2024	25.30
		Check RRV00349967:	25.30					
<b>Total for LINCOLN COUNTY FARM CENTER, INC:</b>			<b>138.14</b>					
LINCOLN COUNTY RURAL WATER DISTRICT#3	Revenue Fund	VO807460	<u>187.10</u>	ACCT#395 WELLSTON MAINT	BPATTERS	RRV00349163	7/1/2024	187.10
		Check RRV00349163:	187.10					
<b>Total for LINCOLN COUNTY RURAL WATER DISTRICT#3:</b>			<b>187.10</b>					
LINCOLN LIQUEFIED GAS CO, INC	Revenue Fund	VO807506	<u>1,194.20</u>	NATURAL & PROPANE GAS	SALLEN	RRV00349199	7/2/2024	1,656.48
		VO807501	<u>183.08</u>	NATURAL AND PROPANE GAS	PGOGGIN			
		VO807505	<u>279.20</u>	NATURAL & PROPANE GAS	PGOGGIN			
		Check RRV00349199:	1,656.48					
LINCOLN LIQUEFIED GAS CO, INC	Revenue Fund	VO809364	<u>90.00</u>	OTHER MAINTENANCE	PGOGGIN	RRV00349968	7/25/2024	1,371.25
		VO809363	<u>495.00</u>	OTHER CONTRACTUAL SERVICES	PGOGGIN			
		VO809400	<u>786.25</u>	NATURAL & PROPANE GAS	JSMART			
		Check RRV00349968:	1,371.25					
<b>Total for LINCOLN LIQUEFIED GAS CO, INC:</b>			<b>3,027.73</b>					



Vendor Name	Fund Desc	Voucher NO.	Amt Applied	Description	Approver	Check No.	Date Paid	Amt Check
LITTLE KANSAS TIRE LLC	Revenue Fund	VO809930	328.00	EQUIPMENT PARTS AND SUPPLIES	CHUGHES	RRV00350068	7/29/2024	328.00
		Check RRV00350068:	328.00					
		<b>Total for LITTLE KANSAS TIRE LLC:</b>	<b>328.00</b>					
LIVELY TAG AGENCY	Revenue Fund	VO808221	17.50	FEE/ISSUANCE 7 PIKEPASS 06/2024	APERINGO	RRV00349531	7/10/2024	17.50
		Check RRV00349531:	17.50					
		<b>Total for LIVELY TAG AGENCY:</b>	<b>17.50</b>					
LIVINGSTON PLUMBING, L.L.C.	Revenue Fund	VO808848	145.00	BUILD MAINT SUPPLIES; OTHER CONTR SERV	DCRAIG	RRV00349839	7/18/2024	145.00
		Check RRV00349839:	145.00					
		<b>Total for LIVINGSTON PLUMBING, L.L.C.:</b>	<b>145.00</b>					
LOCKE SUPPLY CO.	Revenue Fund	VO807507	108.18	SMALL TOOLS AND EQUIPMENT	BWESTER	RRV00349200	7/2/2024	108.18
		Check RRV00349200:	108.18					
LOCKE SUPPLY CO.	Revenue Fund	VO809365	419.20	EQUIPMENT PARTS AND SUPPLIES	JSMART	RRV00349969	7/25/2024	419.20
		Check RRV00349969:	419.20					
LOCKE SUPPLY CO.	Revenue Fund	VO809931	325.53	ROADWAY LIGHTING MAINT SUPP	DCRAIG RROWEN	RRV00350069	7/29/2024	371.52
		VO809933	45.99	BUILDING MAINTENANCE SUPPLIES				
		Check RRV00350069:	371.52					
		<b>Total for LOCKE SUPPLY CO.:</b>	<b>898.90</b>					
LOCUST GROVE TAG AGENCY	Revenue Fund	VO808222	90.00	FEE/ISSUANCE 36 PIKEPASS 06/2024	APERINGO	RRV00349532	7/10/2024	90.00
		Check RRV00349532:	90.00					
		<b>Total for LOCUST GROVE TAG AGENCY:</b>	<b>90.00</b>					
LONE GROVE TAG AGENCY LLC	Revenue Fund	VO808224	17.50	FEE/ISSUANCE 7 PIKEPASS 06/2024	APERINGO	RRV00349533	7/10/2024	17.50
		Check RRV00349533:	17.50					
		<b>Total for LONE GROVE TAG AGENCY LLC:</b>	<b>17.50</b>					
LOOMIS, FARGO & CO.	Revenue Fund	VO808960	49,795.62	ARMORED CAR SVCS, JUNE 2024 ; 13508513	BJEPSEN	REV00016068	7/25/2024	49,795.62
		Check REV00016068:	49,795.62					
		<b>Total for LOOMIS, FARGO &amp; CO.:</b>	<b>49,795.62</b>					
LOT MAINTENANCE OF OKLA. INC.	Revenue Fund	VO808496	55,971.00	MOWING SVCS, MU-M-23 ; 041775	JE4TGATZ JE4TGATZ JEHELLE JEHELLE	REV00016031	7/12/2024	197,348.70
		VO808494	36,508.80	SWEEPING SVCS, SW-IN-23 ; 041600				
		VO808495	23,692.24	MOWING SVCS, CI-M-23 ; 041683				
		VO808497	81,176.66	MOWING SVCS, CI-M-23 ; 041777				
		Check REV00016031:	197,348.70					
LOT MAINTENANCE OF OKLA. INC.	Revenue Fund	VO809068	35,017.50	MOWING SVCS, CK-M-23 ; 041867	JE4TGATZ	REV00016056	7/18/2024	35,017.50
		Check REV00016056:	35,017.50					
		<b>Total for LOT MAINTENANCE OF OKLA. INC.:</b>	<b>232,366.20</b>					
LOVE, GENE	Revenue Fund	VO808823	129.98	JULY 2024 EXPENSES	JPORTER	RRV00349740	7/16/2024	129.98
		Check RRV00349740:	129.98					
		<b>Total for LOVE, GENE:</b>	<b>129.98</b>					
LOWES HOME CENTERS, INC.	Revenue Fund	VO807513	392.69	VEHICLE PARTS; OFFICE EQUIPMENT	PGOGGIN	RRV00349201	7/2/2024	392.69
		Check RRV00349201:	392.69					
LOWES HOME CENTERS, INC.	Revenue Fund	VO807514	13.95	OTHER COMMODITIES AND SUPPLIES	DCRAIG	RRV00349202	7/2/2024	13.95
		Check RRV00349202:	13.95					

Vendor Name	Fund Desc	Voucher NO.	Amt Applied	Description	Approver	Check No.	Date Paid	Amt Check
LOWES HOME CENTERS, INC.	Revenue Fund	VO807925	10.41	BUILDING MAINTENANCE SUPPLIES	PGOGGIN	RRV00349392	7/9/2024	209.98
		VO807933	132.96	SMALL TOOLS AND EQUIPMENT	PGOGGIN			
		VO807928	47.63	BUILDING MAINTENANCE SUPPLIES	PGOGGIN			
		VO807934	18.98	OTHER COMMODITIES AND SUPPLIES	PGOGGIN			
		Check RRV00349392:	209.98					
LOWES HOME CENTERS, INC.	Revenue Fund	VO807941	897.60	BUILDING MAINTENANCE SUPPLIES	KWALLIS	RRV00349393	7/9/2024	897.60
		Check RRV00349393:	897.60					
LOWES HOME CENTERS, INC.	Revenue Fund	VO807938	16.65	BUILDING MAINTENANCE SUPPLIES	BCANTREL	RRV00349394	7/9/2024	16.65
		Check RRV00349394:	16.65					
LOWES HOME CENTERS, INC.	Revenue Fund	VO808880	38.89	VEHICLE PARTS; SMALL TOOLS	JSMITH	RRV00349840	7/18/2024	460.38
		VO808881	22.77	OTHER COMMODITIES AND SUPPLIES	RROWEN			
		VO808883	48.45	EQUIPMENT PARTS AND SUPPLIES	DCRAIG			
		VO808875	73.50	VEHICLE PARTS; EQUIP PARTS; BUILD MAINT	PGOGGIN			
		VO808878	176.08	HARDWARE; BUILD MAINT SUPP; SMALL TOOLS	RDTAYLOR			
		VO808879	36.15	BUILD MAINT SUPPLIES; HARDWARE	JSMART			
		VO808886	64.54	OTHER COMMODITIES; SAFETY SUPPLIES	BELLIS			
Check RRV00349840:	460.38							
LOWES HOME CENTERS, INC.	Revenue Fund	VO809367	15.16	SMALL TOOLS AND EQUIPMENT	PGOGGIN	RRV00349970	7/25/2024	1,105.54
		VO809374	108.22	OTHER COMMODITIES; SMALL TOOLS	PGOGGIN			
		VO809378	354.47	SMALL TOOLS; EQUIP PARTS; OTHER MAINT	TGORE			
		VO809385	64.12	PAINTING SUPPLIES	DCRAIG			
		VO809376	436.05	NONCAP EQUIPMENT	JSMITH			
		VO809382	127.52	CLEANING SUPPLIES; EQUIPMENT PARTS	JSMART			
		Check RRV00349970:	1,105.54					
LOWES HOME CENTERS, INC.	Revenue Fund	VO809938	196.51	SMALL TOOLS; BUILD MAINT SUPP; ASPHALT	PGOGGIN	RRV00350070	7/29/2024	613.27
		VO809943	79.09	SMALL TOOLS; EQUIP PARTS; OTHER MAINT	PGOGGIN			
		VO809945	28.38	ASPHALT & CONCRETE SUPPLIES	PGOGGIN			
		VO809949	12.14	HARDWARE	DCRAIG			
		VO809952	59.82	BUILD MAINT SUPP; ASPHALT SUPPLIES	BCANTREL			
		VO809948	76.47	OTHER COMMODITIES AND SUPPLIES	BWESTER			
		VO809936	29.89	HARDWARE; EQUIPMENT PARTS	PGOGGIN			
		VO809947	130.97	VEHICLE SUPP; SMALL TOOLS; BUILD MAINT	JSMART			
Check RRV00350070:	613.27							
<b>Total for LOWES HOME CENTERS, INC.:</b>			<b>3,710.06</b>					
LOZANO, JUAN	Revenue Fund	VO809348	117.52	JULY 2024 EXPENSES	KWALLIS	RRV00349913	7/23/2024	117.52
		Check RRV00349913:	117.52					
<b>Total for LOZANO, JUAN:</b>			<b>117.52</b>					
LUTHER TAG AGENCY - AUDREY STO	Revenue Fund	VO808225	27.50	FEE/ISSUANCE 11 PIKEPASS 06/2024	APERINGO	RRV00349534	7/10/2024	27.50
		Check RRV00349534:	27.50					
<b>Total for LUTHER TAG AGENCY - AUDREY STONER #8834:</b>			<b>27.50</b>					
MAC ARTHUR ASSOCIATED CONSUL` Capital Projects		VO809546	72,613.48	EWC-28502A: M2 RDWY/DSGN: 22-09E1-01	DBUTLER	23A0000236	7/25/2024	109,907.81
		VO809541	37,294.33	EWC-28802A: M2 RDWY/BRG DSGN: 22-09E5-02	DBUTLER			
		Check 23A0000236:	109,907.81					
<b>Total for MAC ARTHUR ASSOCIATED CONSULTANTS, LTD.:</b>			<b>109,907.81</b>					

Vendor Name	Fund Desc	Voucher NO.	Amt Applied	Description	Approver	Check No.	Date Paid	Amt Check
MAC'S BODY SHOP & TOWING	Revenue Fund	VO807515	3,588.86	VEHICLE PARTS; EQUIPMENT REPAIR	SALLEN	RRV00349205	7/2/2024	3,588.86
		Check RRV00349205:	3,588.86					
		<b>Total for MAC'S BODY SHOP &amp; TOWING:</b>	<b>3,588.86</b>					
MAC'S HYDRAULIC JACK SERVICE, IN	Revenue Fund	VO809410	636.62	EQUIP PARTS; EQUIP REPAIR	DCRAIG	RRV00349971	7/25/2024	636.62
		Check RRV00349971:	636.62					
		<b>Total for MAC'S HYDRAULIC JACK SERVICE, INC:</b>	<b>636.62</b>					
MAC'S TAG AGENCY, LLC	Revenue Fund	VO808226	100.00	FEE/ISSUANCE 40 PIKEPASS 06/2024	APERINGO	RRV00349535	7/10/2024	100.00
		Check RRV00349535:	100.00					
		<b>Total for MAC'S TAG AGENCY, LLC:</b>	<b>100.00</b>					
MAIL WORLD OFFICE	Revenue Fund	VO808227	12.50	FEE/ISSUANCE 5 PIKEPASS 06/2024	APERINGO	RRV00349537	7/10/2024	12.50
		Check RRV00349537:	12.50					
		<b>Total for MAIL WORLD OFFICE:</b>	<b>12.50</b>					
MAINER FORD OF BRISTOW	Revenue Fund	VO808228	2.50	FEE/ISSUANCE 1 PIKEPASS 06/2024	APERINGO	RRV00349536	7/10/2024	2.50
		Check RRV00349536:	2.50					
		<b>Total for MAINER FORD OF BRISTOW:</b>	<b>2.50</b>					
MALIBU'S AUTO CENTER	Revenue Fund	VO808229	35.00	FEE/ISSUANCE 14 PIKEPASS 06/2024	APERINGO	RRV00349538	7/10/2024	35.00
		Check RRV00349538:	35.00					
		<b>Total for MALIBU'S AUTO CENTER:</b>	<b>35.00</b>					
MANGUM TAG AGENCY - #2808	Revenue Fund	VO808231	20.00	FEE/ISSUANCE 8 PIKEPASS 06/2024	APERINGO	RRV00349539	7/10/2024	20.00
		Check RRV00349539:	20.00					
		<b>Total for MANGUM TAG AGENCY - #2808:</b>	<b>20.00</b>					
MANHATTAN ROAD & BRIDGE CO.	General	VO807636	436,015.23	C-MC-29: ESTIMATE NO. 24	TJD4JECH	GEN00021439	7/2/2024	436,015.23
		Check GEN00021439:	436,015.23					
MANHATTAN ROAD & BRIDGE CO.	General	VO808019	383,939.94	C-MC-35: ESTIMATE NO. 6	TJD4JECH	GEN00021453	7/9/2024	383,939.94
		Check GEN00021453:	383,939.94					
		<b>Total for MANHATTAN ROAD &amp; BRIDGE CO.:</b>	<b>819,955.17</b>					
MANNFORD TAG AGENCY	Revenue Fund	VO808232	80.00	FEE/ISSUANCE 32 PIKEPASS 06/2024	APERINGO	RRV00349540	7/10/2024	80.00
		Check RRV00349540:	80.00					
		<b>Total for MANNFORD TAG AGENCY:</b>	<b>80.00</b>					
MARIETTA TAG AGENCY	Revenue Fund	VO808233	7.50	FEE/ISSUANCE 3 PIKEPASS 06/2024	APERINGO	RRV00349542	7/10/2024	7.50
		Check RRV00349542:	7.50					
		<b>Total for MARIETTA TAG AGENCY:</b>	<b>7.50</b>					
MARLOW TAG OFFICE	Revenue Fund	VO808902	172.50	FEE/ISSUANCE 69 PIKEPASS 06/2024	APERINGO	RRV00349783	7/17/2024	172.50
		Check RRV00349783:	172.50					
		<b>Total for MARLOW TAG OFFICE:</b>	<b>172.50</b>					
MARSHALL AUTO PARTS LLC	Revenue Fund	VO807516	49.58	VEHICLE PARTS AND SUPPLIES	K WALLIS	RRV00349206	7/2/2024	97.73
		VO807518	23.85	EQUIPMENT PARTS AND SUPPLIES				
		VO807519	24.30	EQUIPMENT PARTS; SMALL TOOLS				
		Check RRV00349206:	97.73					
MARSHALL AUTO PARTS LLC	Revenue Fund	VO807947	459.54	VEHICLE PARTS AND SUPPLIES	K WALLIS	RRV00349395	7/9/2024	579.19
		VO807946	119.65	VEHICLE PARTS AND SUPPLIES				

Vendor Name	Fund Desc	Voucher NO.	Amt Applied	Description	Approver	Check No.	Date Paid	Amt Check
		Check RRV00349395:	579.19					
MARSHALL AUTO PARTS LLC	Revenue Fund	VO808890	218.39	VEHICLE PARTS AND SUPPLIES	KWALLIS	RRV00349841	7/18/2024	382.47
		VO808892	164.08	VEHICLE PARTS AND SUPPLIES	KWALLIS			
		Check RRV00349841:	382.47					
MARSHALL AUTO PARTS LLC	Revenue Fund	VO809414	281.51	EQUIPMENT PARTS AND SUPPLIES	KWALLIS	RRV00349972	7/25/2024	281.51
		Check RRV00349972:	281.51					
MARSHALL AUTO PARTS LLC	Revenue Fund	VO809955	94.55	VEHICLE PARTS AND SUPPLIES	KWALLIS	RRV00350071	7/29/2024	957.22
		VO809956	597.14	VEHICLE PARTS; EQUIPMENT PARTS	KWALLIS			
		VO809954	120.27	EQUIPMENT PARTS AND SUPPLIES	KWALLIS			
		VO809959	114.12	VEHICLE PARTS; EQUIPMENT PARTS	KWALLIS			
		VO809958	31.14	EQUIPMENT PARTS AND SUPPLIES	KWALLIS			
		Check RRV00350071:	957.22					
		<b>Total for MARSHALL AUTO PARTS LLC:</b>	<b>2,298.12</b>					
MASTERS MECHANICAL LLC	Revenue Fund	VO808894	236.00	EQUIPMENT REPAIR	PGOGGIN	RRV00349842	7/18/2024	236.00
		Check RRV00349842:	236.00					
		<b>Total for MASTERS MECHANICAL LLC:</b>	<b>236.00</b>					
MAXWELL SUPPLY	Revenue Fund	VO807949	314.70	ASPHALT & CONCRETE SUPPLIES; EQUIP PARTS	KWALLIS	RRV00349396	7/9/2024	346.90
		VO807948	32.20	ASPHALT & CONCRETE SUPPLIES	KWALLIS			
		Check RRV00349396:	346.90					
MAXWELL SUPPLY	Revenue Fund	VO807950	1,301.30	ASPHALT & CONCRETE SUPPLIES	MCOLLINS	RRV00349397	7/9/2024	1,301.30
		Check RRV00349397:	1,301.30					
MAXWELL SUPPLY	Revenue Fund	VO809415	96.30	ASPHALT & CONCRETE SUPPLIES	CHUGHES	RRV00349973	7/25/2024	96.30
		Check RRV00349973:	96.30					
MAXWELL SUPPLY	Revenue Fund	VO809543	455.97	ASPHALT & CONCRETE SUPPLIES	CSTEVENS	RRV00349992	7/25/2024	455.97
		Check RRV00349992:	455.97					
MAXWELL SUPPLY	Revenue Fund	VO809963	488.95	EQUIP PARTS; ASPHALT SUPP; HARDWARE	KWALLIS	RRV00350072	7/29/2024	576.83
		VO809965	87.88	HARDWARE	KWALLIS			
		Check RRV00350072:	576.83					
		<b>Total for MAXWELL SUPPLY:</b>	<b>2,777.30</b>					
MAYFAIR KEY & LOCK SHOP	Revenue Fund	VO809967	160.00	OTHER COMMODITIES AND SUPPLIES	PGOGGIN	RRV00350073	7/29/2024	160.00
		Check RRV00350073:	160.00					
		<b>Total for MAYFAIR KEY &amp; LOCK SHOP:</b>	<b>160.00</b>					
MAZZIO'S	Revenue Fund	VO808895	216.70	TRAINING & EDUCATION	JJENKINS	RRV00349843	7/18/2024	216.70
		Check RRV00349843:	216.70					
		<b>Total for MAZZIO'S:</b>	<b>216.70</b>					
MBROH ENGINEERING INC	General	VO809861	33,139.00	IN-MC-71A/71B: FNL/PF PLNS: OTA_18021_05	TJDILL	GEN00021527	7/26/2024	33,139.00
		Check GEN00021527:	33,139.00					
		<b>Total for MBROH ENGINEERING INC:</b>	<b>33,139.00</b>					
MCALESTER TAG AGENCY, LLC	Revenue Fund	VO808235	85.00	FEE/ISSUANCE 34 PIKEPASS 06/2024	APERINGO	RRV00349543	7/10/2024	85.00
		Check RRV00349543:	85.00					
		<b>Total for MCALESTER TAG AGENCY, LLC:</b>	<b>85.00</b>					

Vendor Name	Fund Desc	Voucher NO.	Amt Applied	Description	Approver	Check No.	Date Paid	Amt Check
MCBRIDE CLINIC INC.	Revenue Fund	VO808899	32.00	MEDICAL SERVICES	PGOGGIN	RRV00349844	7/18/2024	32.00
		Check RRV00349844:	32.00					
		<b>Total for MCBRIDE CLINIC INC.:</b>	<b>32.00</b>					
MCCRAW OIL COMPANY INC.	Revenue Fund	VO807547	51.80	VEHICLE PARTS AND SUPPLIES	BWESTER	RRV00349207	7/2/2024	51.80
		Check RRV00349207:	51.80					
		<b>Total for MCCRAW OIL COMPANY INC.:</b>	<b>51.80</b>					
MEADOWS, THE	Revenue Fund	VO807548	121.60	OTHER CONTRACTUAL SERVICES	TGOORE	RRV00349208	7/2/2024	121.60
		Check RRV00349208:	121.60					
		<b>Total for MEADOWS, THE:</b>	<b>121.60</b>					
MEEKER TAG AGENCY - CHERYL MEL	Revenue Fund	VO808236	12.50	FEE/ISSUANCE 5 PIKEPASS 06/2024	APERINGO	RRV00349544	7/10/2024	12.50
		Check RRV00349544:	12.50					
		<b>Total for MEEKER TAG AGENCY - CHERYL MELOTT #4109:</b>	<b>12.50</b>					
MERRITT'S BAKERY	Revenue Fund	VO807549	55.00	EMPLOYEE INCENTIVE AWARDS	RDTAYLOR	RRV00349209	7/2/2024	55.00
		Check RRV00349209:	55.00					
		<b>Total for MERRITT'S BAKERY:</b>	<b>55.00</b>					
MFA PROPANE - STROUD	Revenue Fund	VO808072	169.40	NATURAL & PROPANE GAS	KINMAN	RRV00349398	7/9/2024	426.00
		VO808074	172.40	NATURAL & PROPANE GAS				
		VO808077	84.20	NATURAL & PROPANE GAS				
		Check RRV00349398:	426.00					
		<b>Total for MFA PROPANE - STROUD:</b>	<b>426.00</b>					
MGMT AND ENTERPRISE SERVICES	Revenue Fund	VO808639	60,061.00	TELECOMM, MAY 2024 ; IT00031557	ABOULDEN	REV00016033	7/13/2024	60,061.00
		Check REV00016033:	60,061.00					
MGMT AND ENTERPRISE SERVICES	Revenue Fund	VO808900	4,389.28	FICA SAVINGS JUNE 2024	MGARDNER	RRV00349850	7/18/2024	4,389.28
		Check RRV00349850:	4,389.28					
		<b>Total for MGMT AND ENTERPRISE SERVICES:</b>	<b>64,450.28</b>					
MIAMI PUBLIC UTILITIES	Revenue Fund	VO807717	1,020.44	WATER	BPATTERS	EFT018761	7/5/2024	1,020.44
		Check EFT018761:	1,020.44					
		<b>Total for MIAMI PUBLIC UTILITIES:</b>	<b>1,020.44</b>					
MIDSTATE TRAFFIC CONTROL, INC	Revenue Fund	VO809069	38,680.00	TRAFFIC CNTRL & SFTY SUPPLIES ; 42950	JSMITH	REV00016057	7/18/2024	38,680.00
		Check REV00016057:	38,680.00					
MIDSTATE TRAFFIC CONTROL, INC	Revenue Fund	VO809970	5,600.00	TRAFFIC CONTROL AND SAFETY SUPPLIES	MCOLLINS	RRV00350074	7/29/2024	5,600.00
		Check RRV00350074:	5,600.00					
		<b>Total for MIDSTATE TRAFFIC CONTROL, INC:</b>	<b>44,280.00</b>					
MIDWEST CITY TAG AGENCY	Revenue Fund	VO808238	40.00	FEE/ISSUANCE 16 PIKEPASS 06/2024	APERINGO	RRV00349546	7/10/2024	40.00
		Check RRV00349546:	40.00					
		<b>Total for MIDWEST CITY TAG AGENCY:</b>	<b>40.00</b>					
MIDWEST HOSE & SPECIALTY, INC.	Revenue Fund	VO806986	44.35	EQUIPMENT PARTS AND SUPPLIES	PGOGGIN	RRV00349238	7/2/2024	57.90
		VO806987	13.55	EQUIPMENT PARTS AND SUPPLIES				
		Check RRV00349238:	57.90					
MIDWEST HOSE & SPECIALTY, INC.	Revenue Fund	VO808908	43.83	EQUIPMENT PARTS AND SUPPLIES	JSMART	RRV00349846	7/18/2024	43.83

Vendor Name	Fund Desc	Voucher NO.	Amt Applied	Description	Approver	Check No.	Date Paid	Amt Check
		Check RRV00349846:	43.83					
		<b>Total for MIDWEST HOSE &amp; SPECIALTY, INC.:</b>	<b>101.73</b>					
MIKE'S PEST CONTROL, INC.	Revenue Fund	VO807550	205.00	PEST CONTROL SERVICES	BWESTER	RRV00349212	7/2/2024	205.00
		Check RRV00349212:	205.00					
		<b>Total for MIKE'S PEST CONTROL, INC.:</b>	<b>205.00</b>					
MILLER ENTERPRISES, INC.	Revenue Fund	VO809490	358.83	VEHICLE PARTS; EQUIP REPAIR	RDTAYLOR	RRV00349974	7/25/2024	358.83
		Check RRV00349974:	358.83					
		<b>Total for MILLER ENTERPRISES, INC.:</b>	<b>358.83</b>					
MILLIGAN PARTNERS LLC	General	VO808026	229.92	CUST SVC SUPPORT: INV# 6441	NTAGGART	GEN00021454	7/9/2024	229.92
		Check GEN00021454:	229.92					
MILLIGAN PARTNERS LLC	General	VO808743	2,094.22	GTC CMLPTN /RVW PP & PLTPY: INV# 6440	JPORTER	GEN00021479	7/15/2024	2,094.22
		Check GEN00021479:	2,094.22					
MILLIGAN PARTNERS LLC	General	VO809842	215.00	OTHER PROFESSIONAL SVCS ; 6442	TJD4JECH	GEN00021526	7/26/2024	215.00
		Check GEN00021526:	215.00					
		<b>Total for MILLIGAN PARTNERS LLC:</b>	<b>2,539.14</b>					
MKEC ENGINEERING CONSULTANTS, Capital Projects		VO809321	124,332.04	EWC-28805A: M2 RDWY DSGN/MGMT: 209187	TJDILL	23A0000235	7/22/2024	124,332.04
		Check 23A0000235:	124,332.04					
MKEC ENGINEERING CONSULTANTS, Capital Projects		VO809934	34,947.77	EWC-28805B: M2 DESGN/MGMT: 209839	DBUTLER	23A0000246	7/29/2024	477,006.76
		VO809939	78,355.15	EWC-28805A: DSGN/MGMT: 209846	DBUTLER			
		VO809941	169,955.44	EWC-28605A: DSGN/MGMT: 209844	TJDILL			
		VO809942	193,748.40	EWC-28605B: DSGN/MGMT: 209845	TJDILL			
		Check 23A0000246:	477,006.76					
MKEC ENGINEERING CONSULTANTS, Capital Projects		VO810028	30,322.86	EWC-28405A: DSGN/MGMT: 209841	DBUTLER	23A0000247	7/29/2024	91,947.85
		VO810016	30,417.29	EWC-28505B: DSGN/MGMT: 209843	DBUTLER			
		VO810020	31,207.70	EWC-28505A: DSGN/MGMT: 209842	DBUTLER			
		Check 23A0000247:	91,947.85					
		<b>Total for MKEC ENGINEERING CONSULTANTS, INC.:</b>	<b>693,286.65</b>					
MOHAWK ROCK & SAND CO., INC.	Revenue Fund	VO809972	520.00	PAINTING SUPPLIES	RDTAYLOR	RRV00350075	7/29/2024	520.00
		Check RRV00350075:	520.00					
		<b>Total for MOHAWK ROCK &amp; SAND CO., INC.:</b>	<b>520.00</b>					
MOJO CREATIVE DIGITAL	General	VO809544	14,200.00	OTHER PROFESSIONAL SVCS ; 15408	DMA4TGAT	GEN00021516	7/25/2024	28,400.00
		VO809542	14,200.00	OTHER PROFESSIONAL SVCS ; 15407	DMA4TGAT			
		Check GEN00021516:	28,400.00					
		<b>Total for MOJO CREATIVE DIGITAL:</b>	<b>28,400.00</b>					
MOLLMANS CULLIGAN WATER CO.,   Revenue Fund		VO807404	63.60	EQUIPMENT RENTAL - BOTTLED WATER	JSMITH	RRV00349279	7/5/2024	63.60
		Check RRV00349279:	63.60					
MOLLMANS CULLIGAN WATER CO.,   Revenue Fund		VO808129	9.45	EQUIPMENT RENTAL	JSMITH	RRV00349455	7/9/2024	9.45
		Check RRV00349455:	9.45					
MOLLMANS CULLIGAN WATER CO.,   Revenue Fund		VO809493	38.25	BOTTLED WATER	JSMITH	RRV00349975	7/25/2024	80.70
		VO809492	42.45	BOTTLED WATER; EQUIP RENTAL	JSMITH			
		Check RRV00349975:	80.70					

Vendor Name	Fund Desc	Voucher NO.	Amt Applied	Description	Approver	Check No.	Date Paid	Amt Check
<b>Total for MOLLMANS CULLIGAN WATER CO., INC.:</b>			<b>153.75</b>					
MONAGHAN WARRICK KING	General	VO808173	600.00	WR-MC-131: T-MC-131RW: LGL: 063024CAP04	TJDILL	GEN00021460	7/10/2024	600.00
		Check GEN00021460:	600.00					
MONAGHAN WARRICK KING	General	VO808210	5,606.03	DFWD ROW LGL FEES: INV# 63024	TJDILL	GEN00021464	7/10/2024	5,606.03
		Check GEN00021464:	5,606.03					
<b>Total for MONAGHAN WARRICK KING:</b>			<b>6,206.03</b>					
MOODY'S INVESTORS SERVICE	Revenue Fund	VO809276	31,000.00	ANNUAL MONITORING FEE ; P0469511	WSMITH	REV00016064	7/22/2024	31,000.00
		Check REV00016064:	31,000.00					
<b>Total for MOODY'S INVESTORS SERVICE:</b>			<b>31,000.00</b>					
MOORE TAG AGENCY	Revenue Fund	VO808240	185.00	FEE/ISSUANCE 74 PIKEPASS 06/2024	APERINGO	RRV00349547	7/10/2024	185.00
		Check RRV00349547:	185.00					
<b>Total for MOORE TAG AGENCY:</b>			<b>185.00</b>					
MORRISON PUBLIC WORKS AUTHORITY	Revenue Fund	VO807905	393.54	ACCT#100255 MORRISON WATER & FIRE	BPATTERS	RRV00349333	7/8/2024	393.54
		Check RRV00349333:	393.54					
<b>Total for MORRISON PUBLIC WORKS AUTHORITY:</b>			<b>393.54</b>					
MOTOROLA SOLUTIONS, INC.	General	VO807681	5,775.00	MOTRLA M500 IN-CAR VIDEO SYS: 8281918276	JSMITH	GEN00021445	7/3/2024	121,275.00
		VO807674	115,500.00	MOTRLA M500 IN-CAR VIDEO SYS: 8281919432	TJDILL			
		Check GEN00021445:	121,275.00					
<b>Total for MOTOROLA SOLUTIONS, INC.:</b>			<b>121,275.00</b>					
MR HVAC CONTROLS	Revenue Fund	VO810055	6,350.00	BUILDING MAINTENANCE SERVICES	MCOLLINS	RRV00350092	7/31/2024	6,350.00
		Check RRV00350092:	6,350.00					
<b>Total for MR HVAC CONTROLS:</b>			<b>6,350.00</b>					
MTM RECOGNITION CORPORATION	Revenue Fund	VO807551	224.40	OTHER COMMODITIES AND SUPPLIES	BJESEN	RRV00349210	7/2/2024	224.40
		Check RRV00349210:	224.40					
MTM RECOGNITION CORPORATION	Revenue Fund	VO808909	30.00	OTHER COMMODITIES AND SUPPLIES	BJESEN	RRV00349845	7/18/2024	30.00
		Check RRV00349845:	30.00					
<b>Total for MTM RECOGNITION CORPORATION:</b>			<b>254.40</b>					
MTS BRUSH HOGGING DOZER AND I	General	VO809028	2,841.03	GILCREASE MOWING: GC-M-23: INV# 4338497	MKALKA	GEN00021495	7/17/2024	9,491.03
		VO809030	6,650.00	GILCREASE MOWING: GC-M-23: INV# 4338504	MKALKA			
		Check GEN00021495:	9,491.03					
MTS BRUSH HOGGING DOZER AND I	Revenue Fund	VO809661	119,616.00	MOWING SVCS, HEB-M-23 ; 4338499	TJD4JECH	REV00016073	7/26/2024	119,616.00
		Check REV00016073:	119,616.00					
MTS BRUSH HOGGING DOZER AND I	Revenue Fund	VO810022	23,983.00	MOWING SVCS, KP-M-23 ; 4338501	MKALKA	REV00016081	7/29/2024	102,457.00
		VO810025	78,474.00	MOWING SVCS, TU-M-23 ; 4338498	TJD4JECH			
		Check REV00016081:	102,457.00					
<b>Total for MTS BRUSH HOGGING DOZER AND LAWN LLC:</b>			<b>231,564.03</b>					
MURRAY WOMBLE, INC.	Revenue Fund	VO809499	3,522.25	BUILD MAINT SERV; BUILD MAINT SUPP	TJDILL	RRV00349976	7/25/2024	4,368.75
		VO809495	330.00	BUILDING MAINTENANCE SERVICES	TJDILL			
		VO809498	516.50	BUILD MAINT SUPP; BUILD MAINT SERV	TJDILL			
		Check RRV00349976:	4,368.75					
<b>Total for MURRAY WOMBLE, INC.:</b>			<b>4,368.75</b>					

Vendor Name	Fund Desc	Voucher NO.	Amt Applied	Description	Approver	Check No.	Date Paid	Amt Check
MUSKOGEE REDI-MIX LLC	Revenue Fund	VO807554	1,540.00	ASPHALT & CONCRETE SUPPLIES	MCOLLINS	RRV00349213	7/2/2024	5,313.00
		VO807552	1,540.00	ASPHALT & CONCRETE SUPPLIES				
		VO807553	1,540.00	ASPHALT & CONCRETE SUPPLIES				
		VO807555	693.00	ASPHALT & CONCRETE SUPPLIES				
		Check RRV00349213:	5,313.00					
<b>Total for MUSKOGEE REDI-MIX LLC:</b>			<b>5,313.00</b>					
MUSKOGEE TAG AGENCY - #5117	Revenue Fund	VO808241	257.50	FEE/ISSUANCE 103 PIKEPASS 06/2024	APERINGO	RRV00349548	7/10/2024	257.50
		Check RRV00349548:	257.50					
<b>Total for MUSKOGEE TAG AGENCY - #5117:</b>			<b>257.50</b>					
MUSTANG TAG AGENCY - 0924	Revenue Fund	VO808242	442.50	FEE/ISSUANCE 177 PIKEPASS 06/2024	APERINGO	RRV00349549	7/10/2024	442.50
		Check RRV00349549:	442.50					
<b>Total for MUSTANG TAG AGENCY - 0924:</b>			<b>442.50</b>					
NAPA AUTO PARTS	Revenue Fund	VO807556	50.14	VEHICLE PARTS AND SUPPLIES	JSMITH	RRV00349214	7/2/2024	50.14
		Check RRV00349214:	50.14					
NAPA AUTO PARTS	Revenue Fund	VO809974	71.97	VEHICLE PARTS AND SUPPLIES	PGOGGIN	RRV00350076	7/29/2024	71.97
		Check RRV00350076:	71.97					
<b>Total for NAPA AUTO PARTS:</b>			<b>122.11</b>					
NAPA AUTO PARTS - CUSHING	Revenue Fund	VO808510	4.49	VEHICLE PARTS AND SUPPLIES	RROWEN	RRV00349707	7/12/2024	4.49
		Check RRV00349707:	4.49					
<b>Total for NAPA AUTO PARTS - CUSHING:</b>			<b>4.49</b>					
NEW CORDELL TAG AGENCY	Revenue Fund	VO808243	40.00	FEE/ISSUANCE 16 PIKEPASS 06/2024	APERINGO	RRV00349550	7/10/2024	40.00
		Check RRV00349550:	40.00					
<b>Total for NEW CORDELL TAG AGENCY:</b>			<b>40.00</b>					
NEWCASTLE TAG AGENCY, INC.	Revenue Fund	VO808244	100.00	FEE/ISSUANCE 40 PIKEPASS 06/2024	APERINGO	RRV00349551	7/10/2024	100.00
		Check RRV00349551:	100.00					
<b>Total for NEWCASTLE TAG AGENCY, INC.:</b>			<b>100.00</b>					
NEWKIRK TAG AGENCY	Revenue Fund	VO808245	30.00	FEE/ISSUANCE 12 PIKEPASS 06/2024	APERINGO	RRV00349552	7/10/2024	30.00
		Check RRV00349552:	30.00					
<b>Total for NEWKIRK TAG AGENCY:</b>			<b>30.00</b>					
NICHOLS HILLS PACK AND SHIP	Revenue Fund	VO808246	47.50	FEE/ISSUANCE 19 PIKEPASS 06/2024	APERINGO	RRV00349553	7/10/2024	47.50
		Check RRV00349553:	47.50					
<b>Total for NICHOLS HILLS PACK AND SHIP:</b>			<b>47.50</b>					
NICOMA PARK TAG AGENCY - #8829	Revenue Fund	VO808247	22.50	FEE/ISSUANCE 9 PIKEPASS 06/2024	APERINGO	RRV00349554	7/10/2024	22.50
		Check RRV00349554:	22.50					
<b>Total for NICOMA PARK TAG AGENCY - #8829:</b>			<b>22.50</b>					
NIX, RONDAL	Revenue Fund	VO807627	113.00	JULY 2024 EXPENSES	K WALLIS	RRV00349234	7/2/2024	113.00
		Check RRV00349234:	113.00					
<b>Total for NIX, RONDAL:</b>			<b>113.00</b>					
NOBLE TAG AGENCY	Revenue Fund	VO808248	17.50	FEE/ISSUANCE 7 PIKEPASS 06/2024	APERINGO	RRV00349555	7/10/2024	17.50
		Check RRV00349555:	17.50					
<b>Total for NOBLE TAG AGENCY:</b>			<b>17.50</b>					



Vendor Name	Fund Desc	Voucher NO.	Amt Applied	Description	Approver	Check No.	Date Paid	Amt Check
NORMAN TAG AGENCY - 1435	Revenue Fund	VO808249	125.00	FEE/ISSUANCE 50 PIKEPASS 06/2024	APERINGO	RRV00349556	7/10/2024	125.00
		Check RRV00349556:	125.00					
		<b>Total for NORMAN TAG AGENCY - 1435:</b>	<b>125.00</b>					
NORTHEAST OKLAHOMA ELECTRIC C	Revenue Fund	VO807709	475.15	ELECTRIC	BPATTERS	EFT018758	7/5/2024	475.15
		Check EFT018758:	475.15					
NORTHEAST OKLAHOMA ELECTRIC C	Revenue Fund	VO808667	2,028.72	ELECTRIC	BPATTERS	EFT018803	7/15/2024	2,028.72
		Check EFT018803:	2,028.72					
NORTHEAST OKLAHOMA ELECTRIC C	Revenue Fund	VO808921	34.07	ELECTRIC	BPATTERS	EFT018812	7/17/2024	34.07
		Check EFT018812:	34.07					
<b>Total for NORTHEAST OKLAHOMA ELECTRIC COOP., INC.:</b>			<b>2,537.94</b>					
NORTHERN SAFETY CO., INC.	Revenue Fund	VO809501	312.96	SAFETY & MEDICAL SUPPLIES	KWALLIS	RRV00349977	7/25/2024	391.20
		VO809502	78.24	SAFETY & MEDICAL SUPPLIES				
		Check RRV00349977:	391.20					
<b>Total for NORTHERN SAFETY CO., INC.:</b>			<b>391.20</b>					
NORTHWEST TAG AGENCY	Revenue Fund	VO808250	202.50	FEE/ISSUANCE 81 PIKEPASS 06/2024	APERINGO	RRV00349557	7/10/2024	202.50
		Check RRV00349557:	202.50					
		<b>Total for NORTHWEST TAG AGENCY:</b>	<b>202.50</b>					
NOVOTNY TAG AGENCY	Revenue Fund	VO808251	30.00	FEE/ISSUANCE 12 PIKEPASS 06/2024	APERINGO	RRV00349558	7/10/2024	30.00
		Check RRV00349558:	30.00					
		<b>Total for NOVOTNY TAG AGENCY:</b>	<b>30.00</b>					
NOVUS GLASS	Revenue Fund	VO808252	42.50	FEE/ISSUANCE 17 PIKEPASS 06/2024	APERINGO	RRV00349559	7/10/2024	42.50
		Check RRV00349559:	42.50					
		<b>Total for NOVUS GLASS:</b>	<b>42.50</b>					
O G & E	Revenue Fund	VO807676	4,713.16	ELECTRIC	BPATTERS	EFT018756	7/3/2024	6,343.13
		VO807677	1,629.97	ELECTRIC				
		Check EFT018756:	6,343.13					
O G & E	Revenue Fund	VO807913	2,224.16	ELECTRIC	BPATTERS	EFT018773	7/8/2024	4,343.31
		VO807911	877.89	ELECTRIC				
		VO807915	1,241.26	ELECTRIC				
		Check EFT018773:	4,343.31					
O G & E	Revenue Fund	VO807924	1,499.19	ELECTRIC	BPATTERS	EFT018774	7/8/2024	3,816.93
		VO807930	2,317.74	ELECTRIC				
		Check EFT018774:	3,816.93					
O G & E	Revenue Fund	VO808163	112.29	ELECTRIC	BPATTERS	EFT018785	7/10/2024	9,489.40
		VO808165	2,502.37	ELECTRIC				
		VO808159	2,796.42	ELECTRIC				
		VO808162	512.17	ELECTRIC				
		VO808160	1,260.29	ELECTRIC				
		VO808161	643.31	ELECTRIC				
		VO808164	1,662.55	ELECTRIC				
		Check EFT018785:	9,489.40					

Vendor Name	Fund Desc	Voucher NO.	Amt Applied	Description	Approver	Check No.	Date Paid	Amt Check
O G & E	Revenue Fund	VO808506	1,816.11	ELECTRIC	BPATTERS	EFT018797	7/12/2024	2,568.00
		VO808507	127.90	ELECTRIC				
		VO808509	340.92	ELECTRIC				
		VO808505	108.38	ELECTRIC				
		VO808508	174.69	ELECTRIC				
		Check EFT018797:	2,568.00					
O G & E	Revenue Fund	VO808662	154.05	ELECTRIC	BPATTERS	EFT018804	7/15/2024	1,046.25
		VO808661	892.20	ELECTRIC				
		Check EFT018804:	1,046.25					
O G & E	Revenue Fund	VO808810	1,765.00	ELECTRIC	BPATTERS	EFT018808	7/16/2024	1,765.00
		Check EFT018808:	1,765.00					
O G & E	Revenue Fund	VO809549	624.71	ELECTRIC	BPATTERS	EFT018816	7/25/2024	624.71
		Check EFT018816:	624.71					
O G & E	Revenue Fund	VO809641	5,856.97	ELECTRIC SERVICE	BPATTERS	EFT018817	7/26/2024	5,856.97
		Check EFT018817:	5,856.97					
		<b>Total for O G &amp; E:</b>	<b>35,853.70</b>					
O'REILLY AUTO PARTS-SULPHUR	Revenue Fund	VO809514	149.84	EQUIPMENT PARTS AND SUPPLIES	CSTEVENS	RRV00349982	7/25/2024	197.42
		VO809512	47.58	EQUIPMENT PARTS AND SUPPLIES				
		Check RRV00349982:	197.42					
		<b>Total for O'REILLY AUTO PARTS-SULPHUR:</b>	<b>197.42</b>					
O'REILLY AUTO PARTS - HENRYETTA	Revenue Fund	VO807578	87.07	VEHICLE PARTS AND SUPPLIES	BWESTER	RRV00349219	7/2/2024	87.07
		Check RRV00349219:	87.07					
O'REILLY AUTO PARTS - HENRYETTA	Revenue Fund	VO807064	53.20	VEHICLE PARTS AND SUPPLIES	BWESTER	RRV00349372	7/8/2024	1,288.80
		VO807066	11.43	VEHICLE PARTS AND SUPPLIES				
		VO807067	18.97	VEHICLE PARTS AND SUPPLIES				
		VO807077	25.98	EQUIPMENT PARTS AN SUPPLIES				
		VO807406	362.64	EQUIPMENT PARTS & SUPPLIES				
		VO807058	86.28	VEHICLE PARTS AND SUPPLIES				
		VO807061	-431.40	VEHICLE PARTS AND SUPPLIES				
		VO807405	560.05	VEHICLE PARTS & SUPPLIES				
		VO807053	184.69	VEHICLE PARTS AND SUPPLIES				
		VO807069	327.99	SMALL TOOLS & EQUIP				
		VO807070	71.99	SMALL TOOLS & EQUIP				
		VO807076	16.98	EQUIPMENT PARTS AN SUPPLIES				
		Check RRV00349372:	1,288.80					
		O'REILLY AUTO PARTS - HENRYETTA	Revenue Fund	VO809073				
VO809079	25.03			VEHICLE PARTS AND SUPPLIES				
VO809083	44.94			VEHICLE PARTS AND SUPPLIES				
VO809077	482.97			VEHICLE PARTS AND SUPPLIES				
VO809080	84.31			VEHICLE PARTS AND SUPPLIES				
VO809081	65.88			VEHICLE PARTS AND SUPPLIES				
VO809074	362.64			VEHICLE PARTS AND SUPPLIES				
VO809075	180.48			VEHICLE PARTS AND SUPPLIES				
VO809076	168.20			VEHICLE PARTS AND SUPPLIES				
VO809078	133.80			VEHICLE PARTS AND SUPPLIES				
Check RRV00349857:	1,638.91							

Vendor Name	Fund Desc	Voucher NO.	Amt Applied	Description	Approver	Check No.	Date Paid	Amt Check
O'REILLY AUTO PARTS - HENRYETTA	Revenue Fund	VO810031	21.00	VEHICLE PARTS AND SUPPLIES	BWESTER	RRV00350080	7/29/2024	474.74
		VO810029	453.74	VEHICLE PARTS AND SUPPLIES	BWESTER			
		Check RRV00350080:	474.74					
		<b>Total for O'REILLY AUTO PARTS - HENRYETTA:</b>	<b>3,489.52</b>					
O'REILLY AUTO PARTS - MUSKOGEE	Revenue Fund	VO807565	135.79	VEHICLE PARTS AND SUPPLIES	BCANTREL	RRV00349220	7/2/2024	135.79
		Check RRV00349220:	135.79					
O'REILLY AUTO PARTS - MUSKOGEE	Revenue Fund	VO808099	225.04	VEHICLE PARTS AND SUPPLIES	BCANTREL	RRV00349405	7/9/2024	225.04
		Check RRV00349405:	225.04					
O'REILLY AUTO PARTS - MUSKOGEE	Revenue Fund	VO809056	83.24	VEHICLE PARTS AND SUPPLIES	BCANTREL	RRV00349858	7/18/2024	83.24
		Check RRV00349858:	83.24					
O'REILLY AUTO PARTS - MUSKOGEE	Revenue Fund	VO810015	299.96	EQUIPMENT PARTS AND SUPPLIES	BCANTREL	RRV00350081	7/29/2024	633.49
		VO810019	289.66	VEHICLE PARTS AND SUPPLIES	BCANTREL			
		VO810018	15.83	VEHICLE PARTS AND SUPPLIES	BCANTREL			
		VO810014	28.04	VEHICLE PARTS AND SUPPLIES	BCANTREL			
		Check RRV00350081:	633.49					
<b>Total for O'REILLY AUTO PARTS - MUSKOGEE - N MAIN:</b>	<b>1,077.56</b>							
O'REILLY AUTO PARTS - STILLWATER	Revenue Fund	VO810024	26.84	EQUIPMENT PARTS AND SUPPLIES	RROWEN	RRV00350082	7/29/2024	182.64
		VO810026	155.80	VEHICLE PARTS AND SUPPLIES	RROWEN			
		Check RRV00350082:	182.64					
<b>Total for O'REILLY AUTO PARTS - STILLWATER:</b>	<b>182.64</b>							
O'REILLY AUTO PARTS - TULSA - 91ST	Revenue Fund	VO807561	13.20	VEHICLE PARTS AND SUPPLIES	JJENKINS	RRV00349221	7/2/2024	292.05
		VO807563	2.19	EQUIPMENT PARTS AND SUPPLIES	JJENKINS			
		VO807564	257.68	VEHICLE PARTS AND SUPPLIES	JJENKINS			
		VO807562	18.98	EQUIPMENT PARTS AND SUPPLIES	JJENKINS			
		Check RRV00349221:	292.05					
O'REILLY AUTO PARTS - TULSA - 91ST	Revenue Fund	VO808091	85.79	EQUIPMENT PARTS AND SUPPLIES	JJENKINS	RRV00349406	7/9/2024	251.57
		VO808093	119.06	VEHICLE PARTS AND SUPPLIES	JJENKINS			
		VO808095	46.72	VEHICLE PARTS AND SUPPLIES	JJENKINS			
		Check RRV00349406:	251.57					
O'REILLY AUTO PARTS - TULSA - 91ST	Revenue Fund	VO809509	146.50	EQUIPMENT PARTS AND SUPPLIES	JJENKINS	RRV00349983	7/25/2024	247.09
		VO809511	69.12	VEHICLE PARTS AND SUPPLIES	JJENKINS			
		VO809510	31.47	OTHER COMMODITIES AND SUPPLIES	JJENKINS			
		Check RRV00349983:	247.09					
O'REILLY AUTO PARTS - TULSA - 91ST	Revenue Fund	VO810006	198.58	VEHICLE PARTS AND SUPPLIES	JJENKINS	RRV00350083	7/29/2024	483.48
		VO810012	13.99	OTHER COMMODITIES AND SUPPLIES	JJENKINS			
		VO810008	7.93	VEHICLE PARTS AND SUPPLIES	JJENKINS			
		VO810010	262.98	EQUIPMENT PARTS AND SUPPLIES	JJENKINS			
		Check RRV00350083:	483.48					
<b>Total for O'REILLY AUTO PARTS - TULSA - 91ST ST:</b>	<b>1,274.19</b>							
O'REILLY AUTO PARTS - VINITA	Revenue Fund	VO808090	4.44	EQUIPMENT PARTS AND SUPPLIES	DCRAIG	RRV00349407	7/9/2024	4.44
		Check RRV00349407:	4.44					
<b>Total for O'REILLY AUTO PARTS - VINITA:</b>	<b>4.44</b>							

Vendor Name	Fund Desc	Voucher NO.	Amt Applied	Description	Approver	Check No.	Date Paid	Amt Check
O'REILLY AUTO PARTS- CHANDLER	Revenue Fund	VO808100	<u>181.32</u>	VEHICLE PARTS AND SUPPLIES	RDTAYLOR	RRV00349404	7/9/2024	181.32
		Check RRV00349404:	181.32					
O'REILLY AUTO PARTS- CHANDLER	Revenue Fund	VO809517	<u>53.05</u>	VEHICLE PARTS AND SUPPLIES	RDTAYLOR	RRV00349981	7/25/2024	53.05
		Check RRV00349981:	53.05					
O'REILLY AUTO PARTS- CHANDLER	Revenue Fund	VO810023	<u>4.34</u>	VEHICLE PARTS AND SUPPLIES	RDTAYLOR	RRV00350079	7/29/2024	4.34
		Check RRV00350079:	4.34					
<b>Total for O'REILLY AUTO PARTS- CHANDLER:</b>			<b>238.71</b>					
O'REILLY AUTO PARTS-EDMOND	Revenue Fund	VO807568	291.66	EQUIPMENT PARTS AND SUPPLIES	PGOGGIN	RRV00349218	7/2/2024	745.50
		VO807572	165.47	VEHICLE PARTS AND SUPPLIES				
		VO807574	11.48	VEHICLE PARTS AND SUPPLIES				
		VO807575	150.37	VEHICLE PARTS; SMALL TOOLS				
		VO807571	102.54	EQUIPMENT PARTS AND SUPPLIES				
		VO807577	<u>23.98</u>	VEHICLE PARTS AND SUPPLIES				
Check RRV00349218:	745.50							
O'REILLY AUTO PARTS-EDMOND	Revenue Fund	VO807970	<u>41.97</u>	VEHICLE PARTS & SUPPLIES	JSMART	RRV00349371	7/8/2024	41.97
		Check RRV00349371:	41.97					
O'REILLY AUTO PARTS-EDMOND	Revenue Fund	VO808102	<u>79.94</u>	VEHICLE PARTS AND SUPPLIES	JSMART	RRV00349403	7/9/2024	79.94
		Check RRV00349403:	79.94					
O'REILLY AUTO PARTS-EDMOND	Revenue Fund	VO809061	37.20	EQUIPMENT PARTS AND SUPPLIES	PGOGGIN	RRV00349856	7/18/2024	464.71
		VO809072	38.43	VEHICLE PARTS AND SUPPLIES				
		VO809057	340.52	EQUIPMENT PARTS AND SUPPLIES				
		VO809062	27.99	SAFETY & MEDICAL SUPPLIES				
		VO809070	10.08	VEHICLE PARTS AND SUPPLIES				
		VO809059	<u>10.49</u>	VEHICLE PARTS AND SUPPLIES				
Check RRV00349856:	464.71							
O'REILLY AUTO PARTS-EDMOND	Revenue Fund	VO809515	17.98	SMALL TOOLS; VEHICLE PARTS	JSMART	RRV00349980	7/25/2024	777.65
		VO809518	111.09	VEHICLE PARTS AND SUPPLIES				
		VO809520	54.32	VEHICLE PARTS AND SUPPLIES				
		VO809521	193.55	VEHICLE PARTS AND SUPPLIES				
		VO809519	<u>400.71</u>	VEHICLE PARTS AND SUPPLIES				
Check RRV00349980:	777.65							
<b>Total for O'REILLY AUTO PARTS-EDMOND:</b>			<b>2,109.77</b>					
OFFICE DEPOT	Revenue Fund	VO808079	<u>441.68</u>	OFFICE EQUIPMENT; OFFICE SUPPLIES	ABOULDEN	RRV00349401	7/9/2024	441.68
		Check RRV00349401:	441.68					
OFFICE DEPOT	Revenue Fund	VO809018	70.71	OTHER COMMODITIES; OFFICE SUPPLIES	AHEITZ	RRV00349848	7/18/2024	873.38
		VO809027	52.08	CLEANING SUPPLIES; OFFICE SUPPLIES				
		VO809022	71.29	OTHER COMM; CLEANING; SAFETY				
		VO809029	344.72	CLEANING; OFFICE; OTHER; MEDICAL				
		VO809021	16.32	OFFICE SUPPLIES				
		VO809025	191.94	OFFICE EQUIPMENT				
		VO809031	<u>126.32</u>	OFFICE SUPPLIES; CLEANING SUPPLIES				
		Check RRV00349848:	873.38					
OFFICE DEPOT	Revenue Fund	VO809504	188.71	DATA PROCESSING SUPPLIES	AHEITZ	RRV00349978	7/25/2024	340.77
		VO809503	152.06	OFFICE SUPPLIES				

Vendor Name	Fund Desc	Voucher NO.	Amt Applied	Description	Approver	Check No.	Date Paid	Amt Check
		Check RRV00349940:	340.77					
		<b>Total for OFFICE DEPOT:</b>	<b>1,655.83</b>					
OKIE RENTS	Revenue Fund	VO809053	335.50	EQUIPMENT RENTAL	CSTEVENS	RRV00349849	7/18/2024	335.50
		Check RRV00349849:	335.50					
		<b>Total for OKIE RENTS:</b>	<b>335.50</b>					
OKLAHOMA ASCE	Revenue Fund	VO809359	200.00	BUSINESS EXPENSE	DBUTLER	RRV00349940	7/24/2024	200.00
		Check RRV00349940:	200.00					
		<b>Total for OKLAHOMA ASCE:</b>	<b>200.00</b>					
OKLAHOMA CORRECTIONAL INDUST General		VO808765	5,706.62	PLTPY MNUAL IMG RVW: GILC: #117429	PWILLIAM	GEN00021480	7/15/2024	5,706.62
		Check GEN00021480:	5,706.62					
OKLAHOMA CORRECTIONAL INDUST General		VO809250	6,145.73	PLTPY MNUAL IMG RVW: GILC: 117578	PWILLIAM	GEN00021502	7/19/2024	6,145.73
		Check GEN00021502:	6,145.73					
OKLAHOMA CORRECTIONAL INDUST Revenue Fund		VO809037	136,534.95	OTHER CNTRCTUAL SVCS, MIR ; 117429	DMA4TGAT	REV00016050	7/18/2024	136,534.95
		Check REV00016050:	136,534.95					
OKLAHOMA CORRECTIONAL INDUST Revenue Fund		VO810030	148,915.05	OTHER CNTRCTUAL SVCS, MIR ; 117578	DMA4TGAT	REV00016082	7/29/2024	148,915.05
		Check REV00016082:	148,915.05					
OKLAHOMA CORRECTIONAL INDUST Revenue Fund		VO807558	872.50	SIGNS; SIGN SUPPLIES; OTHR CONTRACT SERV	BWESTER	RRV00349216	7/2/2024	872.50
		Check RRV00349216:	872.50					
		<b>Total for OKLAHOMA CORRECTIONAL INDUSTRIES:</b>	<b>298,174.85</b>					
OKLAHOMA DEPARTMENT OF TRAN Revenue Fund		VO807559	3,915.00	OTHER PROFESSIONAL SERVICES	BJEPSEN	RRV00349215	7/2/2024	3,915.00
		Check RRV00349215:	3,915.00					
OKLAHOMA DEPARTMENT OF TRAN Revenue Fund		VO807921	3,000.00	OTHER PROFESSIONAL SERVICES	BJEPSEN	RRV00349399	7/9/2024	3,000.00
		Check RRV00349399:	3,000.00					
OKLAHOMA DEPARTMENT OF TRAN Revenue Fund		VO808088	3,388.95	BUILDING & REAL ESTATE RENTAL	AHEITZ	RRV00349400	7/9/2024	3,388.95
		Check RRV00349400:	3,388.95					
OKLAHOMA DEPARTMENT OF TRAN Revenue Fund		VO809000	4,060.78	SHARED SERVICE FOR PAYROLL	JSEYMOUR	RRV00349847	7/18/2024	8,292.31
		VO809001	4,231.53	SHARED SERVICES FOR PAYROLL	JSEYMOUR			
		Check RRV00349847:	8,292.31					
OKLAHOMA DEPARTMENT OF TRAN Revenue Fund		VO809997	600.00	SIGNS	RDTAYLOR	RRV00350077	7/29/2024	600.00
		Check RRV00350077:	600.00					
		<b>Total for OKLAHOMA DEPARTMENT OF TRANSPORTATION:</b>	<b>19,196.26</b>					
OKLAHOMA DIRECT	Revenue Fund	VO807666	253.10	FINANCE CHARGE ; 0006410687	TGATZ	REV00016026	7/3/2024	15,786.55
		VO807667	15,533.45	OTHER CNTRCTUAL SVCS ; 0006475194	TGATZ			
		Check REV00016026:	15,786.55					
OKLAHOMA DIRECT	Revenue Fund	VO809047	15,513.98	OTHER CNTRCTUAL SVCS ; 0006536522	TGATZ	REV00016051	7/18/2024	15,513.98
		Check REV00016051:	15,513.98					
		<b>Total for OKLAHOMA DIRECT:</b>	<b>31,300.53</b>					
OKLAHOMA ELECTRIC COOP-NORM/ Revenue Fund		VO807469	2,904.43	ELECTRIC	BPATTERS	EFT018736	7/1/2024	2,904.43
		Check EFT018736:	2,904.43					

Vendor Name	Fund Desc	Voucher NO.	Amt Applied	Description	Approver	Check No.	Date Paid	Amt Check
<b>Total for OKLAHOMA ELECTRIC COOP-NORMAN:</b>			<b>2,904.43</b>					
OKLAHOMA HONDA-SUZUKI	Revenue Fund	VO808253	2.50	FEE/ISSUANCE 1 PIKEPASS 06/2024	APERINGO	RRV00349560	7/10/2024	2.50
		Check RRV00349560:	2.50					
<b>Total for OKLAHOMA HONDA-SUZUKI:</b>			<b>2.50</b>					
OKLAHOMA NATURAL GAS	Revenue Fund	VO807715	1,095.06	GAS	BPATTERS	EFT018762	7/5/2024	1,095.06
		Check EFT018762:	1,095.06					
OKLAHOMA NATURAL GAS	Revenue Fund	VO807712	1,430.95	GAS	BPATTERS	EFT018763	7/5/2024	1,430.95
		Check EFT018763:	1,430.95					
OKLAHOMA NATURAL GAS	Revenue Fund	VO808373	204.88	GAS	BPATTERS	EFT018792	7/11/2024	204.88
		Check EFT018792:	204.88					
OKLAHOMA NATURAL GAS	Revenue Fund	VO808665	178.20	GAS	BPATTERS	EFT018805	7/15/2024	178.20
		Check EFT018805:	178.20					
OKLAHOMA NATURAL GAS	Revenue Fund	VO808811	48.96	GAS SERVICE	BPATTERS	EFT018809	7/16/2024	48.96
		Check EFT018809:	48.96					
<b>Total for OKLAHOMA NATURAL GAS:</b>			<b>2,958.05</b>					
OKLAHOMA PRESS SERVICE, INC.	General	VO808666	181.29	AD: C-MC-36: BRIDGE REHAB. 32.97	DBUTLER	GEN00021484	7/16/2024	181.29
		Check GEN00021484:	181.29					
<b>Total for OKLAHOMA PRESS SERVICE, INC.:</b>			<b>181.29</b>					
OKLAHOMA PUBLIC EMPLOYEES RET	Revenue Fund	VO808504	27,459.46	RETIREMENT,UNUSED SICK LEAVE ; 12121	BJEPSEN	REV00016032	7/12/2024	27,459.46
		Check REV00016032:	27,459.46					
<b>Total for OKLAHOMA PUBLIC EMPLOYEES RETIREMENT SYS:</b>			<b>27,459.46</b>					
OKLAHOMA ROLLOFF, LLC	Revenue Fund	VO808086	550.00	SOLID WASTE DISPOSAL	KWALLIS	RRV00349402	7/9/2024	1,100.00
		VO808084	550.00	SOLID WASTE DISPOSAL	KWALLIS			
		Check RRV00349402:	1,100.00					
<b>Total for OKLAHOMA ROLLOFF, LLC:</b>			<b>1,100.00</b>					
OKLAHOMA TAG OF YUKON	Revenue Fund	VO808254	177.50	FEE/ISSUANCE 71 PIKEPASS 06/2024	APERINGO	RRV00349561	7/10/2024	177.50
		Check RRV00349561:	177.50					
<b>Total for OKLAHOMA TAG OF YUKON:</b>			<b>177.50</b>					
OKLATEL COMMUNICATIONS INC.	Revenue Fund	VO807906	247.50	PHONE SERVICE	JLYTLE	EFT018772	7/8/2024	247.50
		Check EFT018772:	247.50					
<b>Total for OKLATEL COMMUNICATIONS INC.:</b>			<b>247.50</b>					
OLSSON, INC.	Capital Projects	VO809599	28,371.82	IN-36602A: M2/M3 RDWY DSGN: 502652	DBUTLER	23A0000242	7/26/2024	143,260.16
		VO809603	30,000.00	T-26008: M1 30% PLNS: 502086	DBUTLER			
		VO809624	39,298.34	T-26004: M1 30% PLNS/HYD ANALYSIS: 502016	DBUTLER			
		VO809597	3,090.00	IN-36601A: M2 RDWY DSGN: 502027	DBUTLER			
		VO809613	12,500.00	T-26003: M1 30% PLNS: 502013	DBUTLER			
		VO809616	30,000.00	T-26007: M1 30% PLNS: 502083	DBUTLER			
		Check 23A0000242:	143,260.16					
OLSSON, INC.	General	VO808776	18,388.75	TRUST SVC ACCSS- GEC: INV# 500221	DBUTLER	GEN00021481	7/15/2024	207,511.25
		VO808786	179,455.00	T-MC-128: TURNER SVC PLAZA: # 500755	TJDILL			
		VO808783	5,347.50	OTA HQ SEWER LN PRJ: TO 23-12: # 500503	TGORE			

Vendor Name	Fund Desc	Voucher NO.	Amt Applied	Description	Approver	Check No.	Date Paid	Amt Check
		VO808781	4,320.00	TO 24-01: PROF SVC OVRD CHKS: 500510	DBUTLER			
		Check GEN00021481:	207,511.25					
OLSSON, INC.	General	VO809891	16,931.25	OLSSON: TRUST SVC ACCESS- GEC: 503744	DBUTLER	GEN00021530	7/29/2024	16,931.25
		Check GEN00021530:	16,931.25					
OLSSON, INC.	Reserve Maintenance	VO808660	66,618.41	TRUST REQ SVCS, 2024 ; 500541	TJDILL	RMT00006048	7/15/2024	66,618.41
		Check RMT00006048:	66,618.41					
OLSSON, INC.	Reserve Maintenance	VO810065	73,255.37	TRUST REQUIRED SVCS 2024 ; 503759	TJD4JECH	RMT00006058	7/30/2024	73,255.37
		Check RMT00006058:	73,255.37					
		<b>Total for OLSSON, INC.:</b>	<b>507,576.44</b>					
ON CALL SERVICES AND RENTALS LL	Revenue Fund	VO810002	116.27	EQUIPMENT RENTAL; SOLID WASTE DISPOSAL	BCANTREL	RRV00350078	7/29/2024	116.27
		Check RRV00350078:	116.27					
		<b>Total for ON CALL SERVICES AND RENTALS LLC:</b>	<b>116.27</b>					
ONE TIME VENDOR	Revenue Fund	VO808634	28.25	PLA Refund - CMEC INC	NTAGGART	PLA00006213	7/12/2024	28.25
		Check PLA00006213:	28.25					
ONE TIME VENDOR	Revenue Fund	VO808635	49.10	PLA Refund - VERDIER, CHAD	NTAGGART	PLA00006214	7/12/2024	49.10
		Check PLA00006214:	49.10					
ONE TIME VENDOR	Revenue Fund	VO808636	25.90	PLA Refund - REUTER,FRED,,	NTAGGART	PLA00006215	7/12/2024	25.90
		Check PLA00006215:	25.90					
ONE TIME VENDOR	Revenue Fund	VO808637	148.35	PLA Refund - WATSON,WILLIAM,J,	NTAGGART	PLA00006216	7/12/2024	148.35
		Check PLA00006216:	148.35					
ONE TIME VENDOR	Revenue Fund	VO808638	3.50	PLA REFUND - MICHAEL L SCIFRES	GTOLLISO	PLA00006217	7/12/2024	3.50
		Check PLA00006217:	3.50					
ONE TIME VENDOR	Revenue Fund	VO809253	107.70	PLA Refund - CENTRAL MO EXCAVATION CONT	NTAGGART	PLA00006218	7/19/2024	107.70
		Check PLA00006218:	107.70					
ONE TIME VENDOR	Revenue Fund	VO809254	9.30	PLA Refund - EASTON,TIFFAIN,,	NTAGGART	PLA00006219	7/19/2024	9.30
		Check PLA00006219:	9.30					
ONE TIME VENDOR	Revenue Fund	VO809255	14.00	PLA Refund - ALSBORG, THOMAS	NTAGGART	PLA00006220	7/19/2024	14.00
		Check PLA00006220:	14.00					
ONE TIME VENDOR	Revenue Fund	VO809256	17.50	PLA Refund - MURRELL,GERALD,JEFFREY,	NTAGGART	PLA00006221	7/19/2024	17.50
		Check PLA00006221:	17.50					
ONE TIME VENDOR	Revenue Fund	VO809257	35.00	PLA Refund - TRACEY C LAAKE	NTAGGART	PLA00006222	7/19/2024	35.00
		Check PLA00006222:	35.00					
ONE TIME VENDOR	Revenue Fund	VO809258	3.35	PLA Refund - HUBERT,JAMES,,	NTAGGART	PLA00006223	7/19/2024	3.35
		Check PLA00006223:	3.35					
ONE TIME VENDOR	Revenue Fund	VO809259	8.85	PLA Refund - WATSON,NANCY,MITCHELL,	NTAGGART	PLA00006224	7/19/2024	8.85
		Check PLA00006224:	8.85					
ONE TIME VENDOR	Revenue Fund	VO809260	0.81	PLA Refund - LUNSFORD,FEANNER,,	NTAGGART	PLA00006225	7/19/2024	0.81

Vendor Name	Fund Desc	Voucher NO.	Amt Applied	Description	Approver	Check No.	Date Paid	Amt Check
		Check PLA00006225:	0.81					
ONE TIME VENDOR	Revenue Fund	VO809261 Check PLA00006226:	9,400.30 9,400.30	PLA REFUND - LOCKE SUPPLY CO	APERINGO	PLA00006226	7/19/2024	9,400.30
ONE TIME VENDOR	Revenue Fund	VO809264 Check PLA00006227:	6.30 6.30	PLA REFUND - ANGELA BRISLANE	GTOLLISO	PLA00006227	7/19/2024	6.30
ONE TIME VENDOR	Revenue Fund	VO809846 Check PLA00006228:	3.75 3.75	PLA Refund - VERSTRAETE CONVEYABILITY IN	NTAGGART	PLA00006228	7/26/2024	3.75
ONE TIME VENDOR	Revenue Fund	VO809847 Check PLA00006229:	11.40 11.40	PLA Refund - ALLGOOD, MICHAEL LEE	NTAGGART	PLA00006229	7/26/2024	11.40
ONE TIME VENDOR	Revenue Fund	VO809848 Check PLA00006230:	44.75 44.75	PLA Refund - QUICKLE,SHANE,,	NTAGGART	PLA00006230	7/26/2024	44.75
ONE TIME VENDOR	Revenue Fund	VO809849 Check PLA00006231:	252.00 252.00	PLA Refund - BRANDENBURGH, BARBARA BETH	NTAGGART	PLA00006231	7/26/2024	252.00
ONE TIME VENDOR	Revenue Fund	VO809850 Check PLA00006232:	48.20 48.20	PLA Refund - LEA, RICHARD	NTAGGART	PLA00006232	7/26/2024	48.20
ONE TIME VENDOR	Revenue Fund	VO809852 Check PLA00006233:	32.05 32.05	PLA Refund - BOONE,DAVID,,	NTAGGART	PLA00006233	7/26/2024	32.05
ONE TIME VENDOR	Revenue Fund	VO809853 Check PLA00006234:	23.83 23.83	PLA Refund - KEAANNIA, NICOLIA MINUS	NTAGGART	PLA00006234	7/26/2024	23.83
ONE TIME VENDOR	Revenue Fund	VO809854 Check PLA00006235:	7.00 7.00	PLA Refund - BRENDA LEAH WALKER	NTAGGART	PLA00006235	7/26/2024	7.00
ONE TIME VENDOR	Revenue Fund	VO809855 Check PLA00006236:	8.90 8.90	PLA Refund - LITTELL,LADONNA,,	NTAGGART	PLA00006236	7/26/2024	8.90
ONE TIME VENDOR	Revenue Fund	VO809856 Check PLA00006237:	1.70 1.70	PLA Refund - HARDY,ALEXANDRIA,N,	NTAGGART	PLA00006237	7/26/2024	1.70
ONE TIME VENDOR	Revenue Fund	VO809857 Check PLA00006238:	12.90 12.90	PLA Refund - VANEK, JOHN W	NTAGGART	PLA00006238	7/26/2024	12.90
ONE TIME VENDOR	Revenue Fund	VO809858 Check PLA00006239:	2.35 2.35	PLA Refund - JARRETT,DETROY,,	NTAGGART	PLA00006239	7/26/2024	2.35
ONE TIME VENDOR	Revenue Fund	VO809859 Check PLA00006240:	46.70 46.70	PLA Refund - BOONE,DAVID,,	NTAGGART	PLA00006240	7/26/2024	46.70
ONE TIME VENDOR	Revenue Fund	VO809863 Check PLA00006241:	1,794.15 1,794.15	PLA REFUND - LOCKE SUPPLY CO	APERINGO	PLA00006241	7/26/2024	1,794.15
ONE TIME VENDOR	Pikepass	VO807767 Check PPS00141382:	37.95 37.95	PPS Refund - WAYNE L. WARREN	NTAGGART	PPS00141382	7/5/2024	37.95
ONE TIME VENDOR	Pikepass	VO807768	29.60	PPS Refund - FRED L. HICKS	NTAGGART	PPS00141383	7/5/2024	29.60



Vendor Name	Fund Desc	Voucher NO.	Amt Applied	Description	Approver	Check No.	Date Paid	Amt Check
		Check PPS00141383:	29.60					
ONE TIME VENDOR	Pikepass	VO807769	20.85	PPS Refund - KENNETH D. ROBBINS	NTAGGART	PPS00141384	7/5/2024	20.85
		Check PPS00141384:	20.85					
ONE TIME VENDOR	Pikepass	VO807770	18.08	PPS Refund - DANIELLE L. BLACK	NTAGGART	PPS00141385	7/5/2024	18.08
		Check PPS00141385:	18.08					
ONE TIME VENDOR	Pikepass	VO807771	29.11	PPS Refund - DENISE OGDEN	NTAGGART	PPS00141386	7/5/2024	29.11
		Check PPS00141386:	29.11					
ONE TIME VENDOR	Pikepass	VO807772	63.21	PPS Refund - MICHAEL G. MCBRIDE	NTAGGART	PPS00141387	7/5/2024	63.21
		Check PPS00141387:	63.21					
ONE TIME VENDOR	Pikepass	VO807773	19.56	PPS Refund - ALICIA A. SMALES	NTAGGART	PPS00141388	7/5/2024	19.56
		Check PPS00141388:	19.56					
ONE TIME VENDOR	Pikepass	VO807774	9.65	PPS Refund - GINA F. ALBAN	NTAGGART	PPS00141389	7/5/2024	9.65
		Check PPS00141389:	9.65					
ONE TIME VENDOR	Pikepass	VO807775	37.54	PPS Refund - ASHTON R. PHILEMONOF	NTAGGART	PPS00141390	7/5/2024	37.54
		Check PPS00141390:	37.54					
ONE TIME VENDOR	Pikepass	VO807776	16.15	PPS Refund - DEVYN B. HONIG	NTAGGART	PPS00141391	7/5/2024	16.15
		Check PPS00141391:	16.15					
ONE TIME VENDOR	Pikepass	VO807777	40.52	PPS Refund - EVELYN M. HALL	NTAGGART	PPS00141392	7/5/2024	40.52
		Check PPS00141392:	40.52					
ONE TIME VENDOR	Pikepass	VO807778	35.35	PPS Refund - KAYLA A. WILSON	NTAGGART	PPS00141393	7/5/2024	35.35
		Check PPS00141393:	35.35					
ONE TIME VENDOR	Pikepass	VO807779	1.05	PPS Refund - COLLEEN WILSON	NTAGGART	PPS00141394	7/5/2024	1.05
		Check PPS00141394:	1.05					
ONE TIME VENDOR	Pikepass	VO807780	40.00	PPS Refund - KYRIE A. HARRELL	NTAGGART	PPS00141395	7/5/2024	40.00
		Check PPS00141395:	40.00					
ONE TIME VENDOR	Pikepass	VO807781	13.50	PPS Refund - LOUIS T. WILCOXSON	NTAGGART	PPS00141396	7/5/2024	13.50
		Check PPS00141396:	13.50					
ONE TIME VENDOR	Pikepass	VO807782	0.53	PPS Refund - SUSAN LOELIGER	NTAGGART	PPS00141397	7/5/2024	0.53
		Check PPS00141397:	0.53					
ONE TIME VENDOR	Pikepass	VO807783	24.77	PPS Refund - MARY A. SITES	NTAGGART	PPS00141398	7/5/2024	24.77
		Check PPS00141398:	24.77					
ONE TIME VENDOR	Pikepass	VO807784	9.55	PPS Refund - DOROTHY E. HUDSON	NTAGGART	PPS00141399	7/5/2024	9.55
		Check PPS00141399:	9.55					
ONE TIME VENDOR	Pikepass	VO807785	20.31	PPS Refund - LINDA WELCH	NTAGGART	PPS00141400	7/5/2024	20.31
		Check PPS00141400:	20.31					
ONE TIME VENDOR	Pikepass	VO807786	33.12	PPS Refund - STEPHEN G. TINER	NTAGGART	PPS00141401	7/5/2024	33.12

Vendor Name	Fund Desc	Voucher NO.	Amt Applied	Description	Approver	Check No.	Date Paid	Amt Check
		Check PPS00141401:	33.12					
ONE TIME VENDOR	Pikepass	VO807787	24.50	PPS Refund - ADRIENNE RUSS	NTAGGART	PPS00141402	7/5/2024	24.50
		Check PPS00141402:	24.50					
ONE TIME VENDOR	Pikepass	VO807788	37.65	PPS Refund - SUASAN B. MCALISTER	NTAGGART	PPS00141403	7/5/2024	37.65
		Check PPS00141403:	37.65					
ONE TIME VENDOR	Pikepass	VO807789	20.85	PPS Refund - DORENE K. HANSEN	NTAGGART	PPS00141404	7/5/2024	20.85
		Check PPS00141404:	20.85					
ONE TIME VENDOR	Pikepass	VO807790	16.77	PPS Refund - AMY M. WOOD	NTAGGART	PPS00141405	7/5/2024	16.77
		Check PPS00141405:	16.77					
ONE TIME VENDOR	Pikepass	VO807792	35.27	PPS Refund - MELVA J. BUCHHOLZ	NTAGGART	PPS00141406	7/5/2024	35.27
		Check PPS00141406:	35.27					
ONE TIME VENDOR	Pikepass	VO807793	22.59	PPS Refund - WEIHONG WANG	NTAGGART	PPS00141407	7/5/2024	22.59
		Check PPS00141407:	22.59					
ONE TIME VENDOR	Pikepass	VO807794	13.93	PPS Refund - POYYAMOZHI PALANIAPPAN	NTAGGART	PPS00141408	7/5/2024	13.93
		Check PPS00141408:	13.93					
ONE TIME VENDOR	Pikepass	VO807795	1.80	PPS Refund - BEVERLY A. DILLING	NTAGGART	PPS00141409	7/5/2024	1.80
		Check PPS00141409:	1.80					
ONE TIME VENDOR	Pikepass	VO807796	20.55	PPS Refund - DAVID M. HOLLENBECK	NTAGGART	PPS00141410	7/5/2024	20.55
		Check PPS00141410:	20.55					
ONE TIME VENDOR	Pikepass	VO807797	9.76	PPS Refund - CATHERINE B. BROWN	NTAGGART	PPS00141411	7/5/2024	9.76
		Check PPS00141411:	9.76					
ONE TIME VENDOR	Pikepass	VO807798	40.30	PPS Refund - STANLEY BOWLWARE	NTAGGART	PPS00141412	7/5/2024	40.30
		Check PPS00141412:	40.30					
ONE TIME VENDOR	Pikepass	VO807799	24.73	PPS Refund - RYAN D. JACKSON	NTAGGART	PPS00141413	7/5/2024	24.73
		Check PPS00141413:	24.73					
ONE TIME VENDOR	Pikepass	VO807800	8.75	PPS Refund - WESLEY W. SHANKLIN	NTAGGART	PPS00141414	7/5/2024	8.75
		Check PPS00141414:	8.75					
ONE TIME VENDOR	Pikepass	VO807801	14.40	PPS Refund - SARAH E. JONES	NTAGGART	PPS00141415	7/5/2024	14.40
		Check PPS00141415:	14.40					
ONE TIME VENDOR	Pikepass	VO807802	81.08	PPS Refund - MATTHEW A. RAMOS	NTAGGART	PPS00141416	7/5/2024	81.08
		Check PPS00141416:	81.08					
ONE TIME VENDOR	Pikepass	VO807803	30.10	PPS Refund - RONALD L. COLBERT JR	NTAGGART	PPS00141417	7/5/2024	30.10
		Check PPS00141417:	30.10					
ONE TIME VENDOR	Pikepass	VO807804	8.25	PPS Refund - MUTASEM A. SHABAN	NTAGGART	PPS00141418	7/5/2024	8.25
		Check PPS00141418:	8.25					
ONE TIME VENDOR	Pikepass	VO807880	17.55	PPS Refund - SHAWNNETTE K. ELLIOTT	NTAGGART	PPS00141419	7/5/2024	17.55

Vendor Name	Fund Desc	Voucher NO.	Amt Applied	Description	Approver	Check No.	Date Paid	Amt Check
		Check PPS00141419:	17.55					
ONE TIME VENDOR	Pikepass	VO807805	33.80	PPS Refund - WILLIAM A. WILSON	NTAGGART	PPS00141420	7/5/2024	33.80
		Check PPS00141420:	33.80					
ONE TIME VENDOR	Pikepass	VO807806	47.06	PPS Refund - PATRICIA M. HAMILTON	NTAGGART	PPS00141421	7/5/2024	47.06
		Check PPS00141421:	47.06					
ONE TIME VENDOR	Pikepass	VO807807	2.35	PPS Refund - HARVEY E. PENDERGRAFT	NTAGGART	PPS00141422	7/5/2024	2.35
		Check PPS00141422:	2.35					
ONE TIME VENDOR	Pikepass	VO807808	8.30	PPS Refund - BILL H. THOMPSON	NTAGGART	PPS00141423	7/5/2024	8.30
		Check PPS00141423:	8.30					
ONE TIME VENDOR	Pikepass	VO807809	31.75	PPS Refund - MELINDA A. WALKER	NTAGGART	PPS00141424	7/5/2024	31.75
		Check PPS00141424:	31.75					
ONE TIME VENDOR	Pikepass	VO807810	205.09	PPS Refund - ROBERT H. GREEN	NTAGGART	PPS00141425	7/5/2024	205.09
		Check PPS00141425:	205.09					
ONE TIME VENDOR	Pikepass	VO807811	5.71	PPS Refund - JODY H. MORRIS	NTAGGART	PPS00141426	7/5/2024	5.71
		Check PPS00141426:	5.71					
ONE TIME VENDOR	Pikepass	VO807812	33.17	PPS Refund - DORA L. SULLINS	NTAGGART	PPS00141427	7/5/2024	33.17
		Check PPS00141427:	33.17					
ONE TIME VENDOR	Pikepass	VO807813	49.14	PPS Refund - PATRICIA A. BRANTLEY	NTAGGART	PPS00141428	7/5/2024	49.14
		Check PPS00141428:	49.14					
ONE TIME VENDOR	Pikepass	VO807814	27.65	PPS Refund - CLYDE G. ELLISON	NTAGGART	PPS00141429	7/5/2024	27.65
		Check PPS00141429:	27.65					
ONE TIME VENDOR	Pikepass	VO807815	46.90	PPS Refund - JOHN T. PRICE	NTAGGART	PPS00141430	7/5/2024	46.90
		Check PPS00141430:	46.90					
ONE TIME VENDOR	Pikepass	VO807816	28.80	PPS Refund - STACY D. THURBER	NTAGGART	PPS00141431	7/5/2024	28.80
		Check PPS00141431:	28.80					
ONE TIME VENDOR	Pikepass	VO807817	43.95	PPS Refund - DAVID C. WARDEN	NTAGGART	PPS00141432	7/5/2024	43.95
		Check PPS00141432:	43.95					
ONE TIME VENDOR	Pikepass	VO807818	168.64	PPS Refund - JAMES K. FARISH	NTAGGART	PPS00141433	7/5/2024	168.64
		Check PPS00141433:	168.64					
ONE TIME VENDOR	Pikepass	VO807819	21.86	PPS Refund - RAYANNA NARISSETTI	NTAGGART	PPS00141434	7/5/2024	21.86
		Check PPS00141434:	21.86					
ONE TIME VENDOR	Pikepass	VO807820	47.82	PPS Refund - HAROLD R. JACKSON	NTAGGART	PPS00141435	7/5/2024	47.82
		Check PPS00141435:	47.82					
ONE TIME VENDOR	Pikepass	VO807821	51.90	PPS Refund - LARUE M. BUCKNER	NTAGGART	PPS00141436	7/5/2024	51.90
		Check PPS00141436:	51.90					
ONE TIME VENDOR	Pikepass	VO807822	38.70	PPS Refund - JAMES I. REITZ	NTAGGART	PPS00141437	7/5/2024	38.70

Vendor Name	Fund Desc	Voucher NO.	Amt Applied	Description	Approver	Check No.	Date Paid	Amt Check
		Check PPS00141437:	38.70					
ONE TIME VENDOR	Pikepass	VO807823	10.85	PPS Refund - ARDITH WILKERSON	NTAGGART	PPS00141438	7/5/2024	10.85
		Check PPS00141438:	10.85					
ONE TIME VENDOR	Pikepass	VO807824	1,188.00	PPS Refund - ASAP TRANS CORP	NTAGGART	PPS00141439	7/5/2024	1,188.00
		Check PPS00141439:	1,188.00					
ONE TIME VENDOR	Pikepass	VO807825	67.44	PPS Refund - LAURA WILKINSON	NTAGGART	PPS00141440	7/5/2024	67.44
		Check PPS00141440:	67.44					
ONE TIME VENDOR	Pikepass	VO807826	40.00	PPS Refund - STEPHEN DOWNS	NTAGGART	PPS00141441	7/5/2024	40.00
		Check PPS00141441:	40.00					
ONE TIME VENDOR	Pikepass	VO807827	39.50	PPS Refund - HENRY SCHMIDT	NTAGGART	PPS00141442	7/5/2024	39.50
		Check PPS00141442:	39.50					
ONE TIME VENDOR	Pikepass	VO807828	33.29	PPS Refund - MIKE R. SCHUSTER	NTAGGART	PPS00141443	7/5/2024	33.29
		Check PPS00141443:	33.29					
ONE TIME VENDOR	Pikepass	VO807829	25.64	PPS Refund - DAVE MALOY	NTAGGART	PPS00141444	7/5/2024	25.64
		Check PPS00141444:	25.64					
ONE TIME VENDOR	Pikepass	VO807830	49.55	PPS Refund - ROGER D. MOULIN	NTAGGART	PPS00141445	7/5/2024	49.55
		Check PPS00141445:	49.55					
ONE TIME VENDOR	Pikepass	VO807831	4.70	PPS Refund - DONNA A. MILLER	NTAGGART	PPS00141446	7/5/2024	4.70
		Check PPS00141446:	4.70					
ONE TIME VENDOR	Pikepass	VO807832	35.10	PPS Refund - JOHN S. ADAMS	NTAGGART	PPS00141447	7/5/2024	35.10
		Check PPS00141447:	35.10					
ONE TIME VENDOR	Pikepass	VO807833	49.50	PPS Refund - HAZEL A. STEPHENS	NTAGGART	PPS00141448	7/5/2024	49.50
		Check PPS00141448:	49.50					
ONE TIME VENDOR	Pikepass	VO807834	27.86	PPS Refund - CHARLES W. MCGUIRE	NTAGGART	PPS00141449	7/5/2024	27.86
		Check PPS00141449:	27.86					
ONE TIME VENDOR	Pikepass	VO807835	295.61	PPS Refund - MAHAN LLC	NTAGGART	PPS00141450	7/5/2024	295.61
		Check PPS00141450:	295.61					
ONE TIME VENDOR	Pikepass	VO807836	44.60	PPS Refund - DANNY L. WATKINS	NTAGGART	PPS00141451	7/5/2024	44.60
		Check PPS00141451:	44.60					
ONE TIME VENDOR	Pikepass	VO807837	15.84	PPS Refund - JULIE L. OLIVER	NTAGGART	PPS00141452	7/5/2024	15.84
		Check PPS00141452:	15.84					
ONE TIME VENDOR	Pikepass	VO807838	12.87	PPS Refund - KARL W. KIBLER	NTAGGART	PPS00141453	7/5/2024	12.87
		Check PPS00141453:	12.87					
ONE TIME VENDOR	Pikepass	VO807839	28.85	PPS Refund - BONNIE SHEPPARD	NTAGGART	PPS00141454	7/5/2024	28.85
		Check PPS00141454:	28.85					
ONE TIME VENDOR	Pikepass	VO807840	27.67	PPS Refund - RANDY G. BALL	NTAGGART	PPS00141455	7/5/2024	27.67

Vendor Name	Fund Desc	Voucher NO.	Amt Applied	Description	Approver	Check No.	Date Paid	Amt Check
		Check PPS00141455:	27.67					
ONE TIME VENDOR	Pikepass	VO807842	57.02	PPS Refund - JACKIE S. SCOVEL	NTAGGART	PPS00141457	7/5/2024	57.02
		Check PPS00141457:	57.02					
ONE TIME VENDOR	Pikepass	VO807843	28.00	PPS Refund - SANDRA K. WALTERS	NTAGGART	PPS00141458	7/5/2024	28.00
		Check PPS00141458:	28.00					
ONE TIME VENDOR	Pikepass	VO807844	0.20	PPS Refund - ASHTYN K. HOUSTON	NTAGGART	PPS00141459	7/5/2024	0.20
		Check PPS00141459:	0.20					
ONE TIME VENDOR	Pikepass	VO807845	33.25	PPS Refund - NICHOLAS A. SCHINTGEN	NTAGGART	PPS00141460	7/5/2024	33.25
		Check PPS00141460:	33.25					
ONE TIME VENDOR	Pikepass	VO807847	223.55	PPS Refund - CAITLIN C. THOMPSON	NTAGGART	PPS00141462	7/5/2024	223.55
		Check PPS00141462:	223.55					
ONE TIME VENDOR	Pikepass	VO807848	100.00	PPS Refund - DEKIA L. FORD	NTAGGART	PPS00141463	7/5/2024	100.00
		Check PPS00141463:	100.00					
ONE TIME VENDOR	Pikepass	VO807849	49.00	PPS Refund - VIRGINIA E. BAIN	NTAGGART	PPS00141464	7/5/2024	49.00
		Check PPS00141464:	49.00					
ONE TIME VENDOR	Pikepass	VO807850	47.69	PPS Refund - JENNETH F. SHEELER	NTAGGART	PPS00141465	7/5/2024	47.69
		Check PPS00141465:	47.69					
ONE TIME VENDOR	Pikepass	VO807851	13.45	PPS Refund - KENNETH EASON	NTAGGART	PPS00141466	7/5/2024	13.45
		Check PPS00141466:	13.45					
ONE TIME VENDOR	Pikepass	VO807852	42.97	PPS Refund - JEANNE M. BURKHOLDER	NTAGGART	PPS00141467	7/5/2024	42.97
		Check PPS00141467:	42.97					
ONE TIME VENDOR	Pikepass	VO807853	53.19	PPS Refund - BRIDGET D. BIRDWELL	NTAGGART	PPS00141468	7/5/2024	53.19
		Check PPS00141468:	53.19					
ONE TIME VENDOR	Pikepass	VO807854	27.56	PPS Refund - THERESA JONES	NTAGGART	PPS00141469	7/5/2024	27.56
		Check PPS00141469:	27.56					
ONE TIME VENDOR	Pikepass	VO807855	37.15	PPS Refund - JOHN T. LOCKE	NTAGGART	PPS00141470	7/5/2024	37.15
		Check PPS00141470:	37.15					
ONE TIME VENDOR	Pikepass	VO807856	41.96	PPS Refund - HELEN D. HOFFSTATTER	NTAGGART	PPS00141471	7/5/2024	41.96
		Check PPS00141471:	41.96					
ONE TIME VENDOR	Pikepass	VO807857	44.35	PPS Refund - BAILEY'S WELDING & MACHINE	NTAGGART	PPS00141472	7/5/2024	44.35
		Check PPS00141472:	44.35					
ONE TIME VENDOR	Pikepass	VO807858	47.84	PPS Refund - PONCA CITY DEVELOPMENT AUTH	NTAGGART	PPS00141473	7/5/2024	47.84
		Check PPS00141473:	47.84					
ONE TIME VENDOR	Pikepass	VO807859	53.82	PPS Refund - CHARLES N. SANDINI	NTAGGART	PPS00141474	7/5/2024	53.82
		Check PPS00141474:	53.82					
ONE TIME VENDOR	Pikepass	VO807860	11.31	PPS Refund - LES D. AKINS	NTAGGART	PPS00141475	7/5/2024	11.31

Vendor Name	Fund Desc	Voucher NO.	Amt Applied	Description	Approver	Check No.	Date Paid	Amt Check
		Check PPS00141475:	11.31					
ONE TIME VENDOR	Pikepass	VO807861	15.17	PPS Refund - MICHAEL D. STANFILL	NTAGGART	PPS00141476	7/5/2024	15.17
		Check PPS00141476:	15.17					
ONE TIME VENDOR	Pikepass	VO807862	12.68	PPS Refund - SARA J. BOECKMAN	NTAGGART	PPS00141477	7/5/2024	12.68
		Check PPS00141477:	12.68					
ONE TIME VENDOR	Pikepass	VO807863	17.33	PPS Refund - ROBERT E. WAY	NTAGGART	PPS00141478	7/5/2024	17.33
		Check PPS00141478:	17.33					
ONE TIME VENDOR	Pikepass	VO807864	22.05	PPS Refund - DAVID L. LOUDERMILK	NTAGGART	PPS00141479	7/5/2024	22.05
		Check PPS00141479:	22.05					
ONE TIME VENDOR	Pikepass	VO807865	12.87	PPS Refund - JARED A. KASPER	NTAGGART	PPS00141480	7/5/2024	12.87
		Check PPS00141480:	12.87					
ONE TIME VENDOR	Pikepass	VO807866	23.49	PPS Refund - PATCHAMAPORN BECK	NTAGGART	PPS00141481	7/5/2024	23.49
		Check PPS00141481:	23.49					
ONE TIME VENDOR	Pikepass	VO807867	5.80	PPS Refund - JENNIFER WINGENDER	NTAGGART	PPS00141482	7/5/2024	5.80
		Check PPS00141482:	5.80					
ONE TIME VENDOR	Pikepass	VO807868	33.20	PPS Refund - RICHARD L. FLEMING	NTAGGART	PPS00141483	7/5/2024	33.20
		Check PPS00141483:	33.20					
ONE TIME VENDOR	Pikepass	VO807869	24.50	PPS Refund - NEAL JONES	NTAGGART	PPS00141484	7/5/2024	24.50
		Check PPS00141484:	24.50					
ONE TIME VENDOR	Pikepass	VO807870	68.10	PPS Refund - JULIUS ASONG	NTAGGART	PPS00141485	7/5/2024	68.10
		Check PPS00141485:	68.10					
ONE TIME VENDOR	Pikepass	VO807871	16.56	PPS Refund - ETHAN J. TROMBLEY	NTAGGART	PPS00141486	7/5/2024	16.56
		Check PPS00141486:	16.56					
ONE TIME VENDOR	Pikepass	VO807872	1.45	PPS Refund - SETH N. ADCOCK	NTAGGART	PPS00141487	7/5/2024	1.45
		Check PPS00141487:	1.45					
ONE TIME VENDOR	Pikepass	VO807873	74.55	PPS Refund - THOMAS E. TAPIA	NTAGGART	PPS00141488	7/5/2024	74.55
		Check PPS00141488:	74.55					
ONE TIME VENDOR	Pikepass	VO807874	24.85	PPS Refund - JEFFREY D. KRAMER	NTAGGART	PPS00141489	7/5/2024	24.85
		Check PPS00141489:	24.85					
ONE TIME VENDOR	Pikepass	VO807875	31.60	PPS Refund - MARIAN BENGGOA	NTAGGART	PPS00141490	7/5/2024	31.60
		Check PPS00141490:	31.60					
ONE TIME VENDOR	Pikepass	VO807876	269.09	PPS Refund - JARROD K. BERRY	NTAGGART	PPS00141491	7/5/2024	269.09
		Check PPS00141491:	269.09					
ONE TIME VENDOR	Pikepass	VO807882	40.00	PPS Refund - TAYLOR KENDRICK	NTAGGART	PPS00141492	7/5/2024	40.00
		Check PPS00141492:	40.00					
ONE TIME VENDOR	Pikepass	VO808536	43.00	PPS Refund - PATRICIA A. MERCER	NTAGGART	PPS00141493	7/12/2024	43.00

Vendor Name	Fund Desc	Voucher NO.	Amt Applied	Description	Approver	Check No.	Date Paid	Amt Check
		Check PPS00141493:	43.00					
ONE TIME VENDOR	Pikepass	VO808537	42.05	PPS Refund - STEVE J. CUSACK	NTAGGART	PPS00141494	7/12/2024	42.05
		Check PPS00141494:	42.05					
ONE TIME VENDOR	Pikepass	VO808538	36.05	PPS Refund - RUTH DELOZIER	NTAGGART	PPS00141495	7/12/2024	36.05
		Check PPS00141495:	36.05					
ONE TIME VENDOR	Pikepass	VO808539	56.42	PPS Refund - MICHAEL W. HENDERSON	NTAGGART	PPS00141496	7/12/2024	56.42
		Check PPS00141496:	56.42					
ONE TIME VENDOR	Pikepass	VO808540	35.83	PPS Refund - ELVA R. WESTERMARK	NTAGGART	PPS00141497	7/12/2024	35.83
		Check PPS00141497:	35.83					
ONE TIME VENDOR	Pikepass	VO808542	42.49	PPS Refund - PAMELA GOSNELL	NTAGGART	PPS00141499	7/12/2024	42.49
		Check PPS00141499:	42.49					
ONE TIME VENDOR	Pikepass	VO808543	38.95	PPS Refund - DEANNA K. LARUE	NTAGGART	PPS00141500	7/12/2024	38.95
		Check PPS00141500:	38.95					
ONE TIME VENDOR	Pikepass	VO808544	14.18	PPS Refund - CHRISTINE L. DUFF	NTAGGART	PPS00141501	7/12/2024	14.18
		Check PPS00141501:	14.18					
ONE TIME VENDOR	Pikepass	VO808545	43.26	PPS Refund - MIKE G. FOX	NTAGGART	PPS00141502	7/12/2024	43.26
		Check PPS00141502:	43.26					
ONE TIME VENDOR	Pikepass	VO808546	39.26	PPS Refund - SHANNON D. GEORGE	NTAGGART	PPS00141503	7/12/2024	39.26
		Check PPS00141503:	39.26					
ONE TIME VENDOR	Pikepass	VO808547	13.50	PPS Refund - JOHN DODD	NTAGGART	PPS00141504	7/12/2024	13.50
		Check PPS00141504:	13.50					
ONE TIME VENDOR	Pikepass	VO808548	97.90	PPS Refund - KALE W. MOUSER	NTAGGART	PPS00141505	7/12/2024	97.90
		Check PPS00141505:	97.90					
ONE TIME VENDOR	Pikepass	VO808549	30.90	PPS Refund - ALYSIA K. ATTEBERY	NTAGGART	PPS00141506	7/12/2024	30.90
		Check PPS00141506:	30.90					
ONE TIME VENDOR	Pikepass	VO808550	34.92	PPS Refund - MARY BITNEY	NTAGGART	PPS00141507	7/12/2024	34.92
		Check PPS00141507:	34.92					
ONE TIME VENDOR	Pikepass	VO808551	17.75	PPS Refund - JENNIFER M. LOUCKS	NTAGGART	PPS00141508	7/12/2024	17.75
		Check PPS00141508:	17.75					
ONE TIME VENDOR	Pikepass	VO808552	12.41	PPS Refund - SAHIB S. KHALSA	NTAGGART	PPS00141509	7/12/2024	12.41
		Check PPS00141509:	12.41					
ONE TIME VENDOR	Pikepass	VO808553	11.35	PPS Refund - RANDY L. COPLEN	NTAGGART	PPS00141510	7/12/2024	11.35
		Check PPS00141510:	11.35					
ONE TIME VENDOR	Pikepass	VO808554	36.36	PPS Refund - JAMES W. TOWNER	NTAGGART	PPS00141511	7/12/2024	36.36
		Check PPS00141511:	36.36					
ONE TIME VENDOR	Pikepass	VO808555	23.88	PPS Refund - JEFF M. DANNER	NTAGGART	PPS00141512	7/12/2024	23.88

Vendor Name	Fund Desc	Voucher NO.	Amt Applied	Description	Approver	Check No.	Date Paid	Amt Check
		Check PPS00141512:	23.88					
ONE TIME VENDOR	Pikepass	VO808556	16.20	PPS Refund - DAVID K. HOPSON	NTAGGART	PPS00141513	7/12/2024	16.20
		Check PPS00141513:	16.20					
ONE TIME VENDOR	Pikepass	VO808557	44.80	PPS Refund - ALEXANDRIA J. BARIOS	NTAGGART	PPS00141514	7/12/2024	44.80
		Check PPS00141514:	44.80					
ONE TIME VENDOR	Pikepass	VO808558	28.71	PPS Refund - DEBORAH K. FIEGENER	NTAGGART	PPS00141515	7/12/2024	28.71
		Check PPS00141515:	28.71					
ONE TIME VENDOR	Pikepass	VO808559	68.47	PPS Refund - MCCONNELL SHAW	NTAGGART	PPS00141516	7/12/2024	68.47
		Check PPS00141516:	68.47					
ONE TIME VENDOR	Pikepass	VO808560	6.38	PPS Refund - MARIAH ELLIS	NTAGGART	PPS00141517	7/12/2024	6.38
		Check PPS00141517:	6.38					
ONE TIME VENDOR	Pikepass	VO808561	33.10	PPS Refund - JARED STORTS	NTAGGART	PPS00141518	7/12/2024	33.10
		Check PPS00141518:	33.10					
ONE TIME VENDOR	Pikepass	VO808562	8.95	PPS Refund - KATHLEEN FEELEY	NTAGGART	PPS00141519	7/12/2024	8.95
		Check PPS00141519:	8.95					
ONE TIME VENDOR	Pikepass	VO808563	12.90	PPS Refund - TERICA SMITH	NTAGGART	PPS00141520	7/12/2024	12.90
		Check PPS00141520:	12.90					
ONE TIME VENDOR	Pikepass	VO808564	31.70	PPS Refund - FAHEY FLEEHEART	NTAGGART	PPS00141521	7/12/2024	31.70
		Check PPS00141521:	31.70					
ONE TIME VENDOR	Pikepass	VO808565	16.75	PPS Refund - BETHANY FILLA	NTAGGART	PPS00141522	7/12/2024	16.75
		Check PPS00141522:	16.75					
ONE TIME VENDOR	Pikepass	VO808566	25.10	PPS Refund - BRANDON B. MATHENY	NTAGGART	PPS00141523	7/12/2024	25.10
		Check PPS00141523:	25.10					
ONE TIME VENDOR	Pikepass	VO808567	34.00	PPS Refund - BRENDA C. PENA CASTRO	NTAGGART	PPS00141524	7/12/2024	34.00
		Check PPS00141524:	34.00					
ONE TIME VENDOR	Pikepass	VO808568	30.95	PPS Refund - TROY SYBRANDTS	NTAGGART	PPS00141525	7/12/2024	30.95
		Check PPS00141525:	30.95					
ONE TIME VENDOR	Pikepass	VO808569	21.05	PPS Refund - KATELYNN M. WILLARD	NTAGGART	PPS00141526	7/12/2024	21.05
		Check PPS00141526:	21.05					
ONE TIME VENDOR	Pikepass	VO808570	40.00	PPS Refund - KEVIN PRASKA	NTAGGART	PPS00141527	7/12/2024	40.00
		Check PPS00141527:	40.00					
ONE TIME VENDOR	Pikepass	VO808571	43.35	PPS Refund - ELIZABETH KEHOE	NTAGGART	PPS00141528	7/12/2024	43.35
		Check PPS00141528:	43.35					
ONE TIME VENDOR	Pikepass	VO808572	25.73	PPS Refund - GLENDA L. HOOVER	NTAGGART	PPS00141529	7/12/2024	25.73
		Check PPS00141529:	25.73					
ONE TIME VENDOR	Pikepass	VO808573	10.55	PPS Refund - PHILLIP E. WILLEY	NTAGGART	PPS00141530	7/12/2024	10.55



Vendor Name	Fund Desc	Voucher NO.	Amt Applied	Description	Approver	Check No.	Date Paid	Amt Check
		Check PPS00141530:	10.55					
ONE TIME VENDOR	Pikepass	VO808574	1.20	PPS Refund - TATUM T. EARLE	NTAGGART	PPS00141531	7/12/2024	1.20
		Check PPS00141531:	1.20					
ONE TIME VENDOR	Pikepass	VO808575	34.48	PPS Refund - BARBARA D. STOUT	NTAGGART	PPS00141532	7/12/2024	34.48
		Check PPS00141532:	34.48					
ONE TIME VENDOR	Pikepass	VO808576	22.35	PPS Refund - JENEAN A. BEAVER	NTAGGART	PPS00141533	7/12/2024	22.35
		Check PPS00141533:	22.35					
ONE TIME VENDOR	Pikepass	VO808577	31.35	PPS Refund - STELLA A. WOLF	NTAGGART	PPS00141534	7/12/2024	31.35
		Check PPS00141534:	31.35					
ONE TIME VENDOR	Pikepass	VO808578	69.85	PPS Refund - WILLIAM R. EATON	NTAGGART	PPS00141535	7/12/2024	69.85
		Check PPS00141535:	69.85					
ONE TIME VENDOR	Pikepass	VO808579	13.50	PPS Refund - DANNY W. BROWN	NTAGGART	PPS00141536	7/12/2024	13.50
		Check PPS00141536:	13.50					
ONE TIME VENDOR	Pikepass	VO808580	79.70	PPS Refund - CHRYSANTHA DAVIS	NTAGGART	PPS00141537	7/12/2024	79.70
		Check PPS00141537:	79.70					
ONE TIME VENDOR	Pikepass	VO808581	39.70	PPS Refund - JOHN M. MCCAULEY	NTAGGART	PPS00141538	7/12/2024	39.70
		Check PPS00141538:	39.70					
ONE TIME VENDOR	Pikepass	VO808582	37.40	PPS Refund - JAMIE PIETROPAOLO	NTAGGART	PPS00141539	7/12/2024	37.40
		Check PPS00141539:	37.40					
ONE TIME VENDOR	Pikepass	VO808583	19.37	PPS Refund - MARJORIE J. NEASE	NTAGGART	PPS00141540	7/12/2024	19.37
		Check PPS00141540:	19.37					
ONE TIME VENDOR	Pikepass	VO808584	35.18	PPS Refund - DONNIE R. WHISENHUNT	NTAGGART	PPS00141541	7/12/2024	35.18
		Check PPS00141541:	35.18					
ONE TIME VENDOR	Pikepass	VO808585	28.30	PPS Refund - WILLIAM E. HOWARD	NTAGGART	PPS00141542	7/12/2024	28.30
		Check PPS00141542:	28.30					
ONE TIME VENDOR	Pikepass	VO808586	31.88	PPS Refund - DEWAYNE ODEN	NTAGGART	PPS00141543	7/12/2024	31.88
		Check PPS00141543:	31.88					
ONE TIME VENDOR	Pikepass	VO808587	32.48	PPS Refund - JERRY T. HANEL	NTAGGART	PPS00141544	7/12/2024	32.48
		Check PPS00141544:	32.48					
ONE TIME VENDOR	Pikepass	VO808588	33.21	PPS Refund - SALLY A. HUTCHINSON	NTAGGART	PPS00141545	7/12/2024	33.21
		Check PPS00141545:	33.21					
ONE TIME VENDOR	Pikepass	VO808589	19.60	PPS Refund - MINTA Z. TAUER	NTAGGART	PPS00141546	7/12/2024	19.60
		Check PPS00141546:	19.60					
ONE TIME VENDOR	Pikepass	VO808590	67.38	PPS Refund - SHARON HORTON	NTAGGART	PPS00141547	7/12/2024	67.38
		Check PPS00141547:	67.38					
ONE TIME VENDOR	Pikepass	VO808591	12.40	PPS Refund - MARGIE LAWLES	NTAGGART	PPS00141548	7/12/2024	12.40

Vendor Name	Fund Desc	Voucher NO.	Amt Applied	Description	Approver	Check No.	Date Paid	Amt Check
		Check PPS00141548:	12.40					
ONE TIME VENDOR	Pikepass	VO808592	11.91	PPS Refund - CARREN D. WELCH	NTAGGART	PPS00141549	7/12/2024	11.91
		Check PPS00141549:	11.91					
ONE TIME VENDOR	Pikepass	VO808593	20.15	PPS Refund - JOANN HIBBERT	NTAGGART	PPS00141550	7/12/2024	20.15
		Check PPS00141550:	20.15					
ONE TIME VENDOR	Pikepass	VO808594	32.67	PPS Refund - AUTUMN M. HOHENSEE	NTAGGART	PPS00141551	7/12/2024	32.67
		Check PPS00141551:	32.67					
ONE TIME VENDOR	Pikepass	VO808595	43.44	PPS Refund - TERRY L. YANTES	NTAGGART	PPS00141552	7/12/2024	43.44
		Check PPS00141552:	43.44					
ONE TIME VENDOR	Pikepass	VO808596	25.30	PPS Refund - CONRAD F. HERMAN	NTAGGART	PPS00141553	7/12/2024	25.30
		Check PPS00141553:	25.30					
ONE TIME VENDOR	Pikepass	VO808597	9.95	PPS Refund - CHRISTOPHER J. LIEBIG	NTAGGART	PPS00141554	7/12/2024	9.95
		Check PPS00141554:	9.95					
ONE TIME VENDOR	Pikepass	VO808598	8.63	PPS Refund - ELAINE BINKLEY	NTAGGART	PPS00141555	7/12/2024	8.63
		Check PPS00141555:	8.63					
ONE TIME VENDOR	Pikepass	VO808599	48.50	PPS Refund - OCTAVIO PENA	NTAGGART	PPS00141556	7/12/2024	48.50
		Check PPS00141556:	48.50					
ONE TIME VENDOR	Pikepass	VO808600	15.21	PPS Refund - TCBC LLC	NTAGGART	PPS00141557	7/12/2024	15.21
		Check PPS00141557:	15.21					
ONE TIME VENDOR	Pikepass	VO808601	49.03	PPS Refund - JORDAN T. CLAUSON	NTAGGART	PPS00141558	7/12/2024	49.03
		Check PPS00141558:	49.03					
ONE TIME VENDOR	Pikepass	VO808602	31.72	PPS Refund - HALEY A. BRANCH	NTAGGART	PPS00141559	7/12/2024	31.72
		Check PPS00141559:	31.72					
ONE TIME VENDOR	Pikepass	VO808603	12.27	PPS Refund - ERICA G. KING	NTAGGART	PPS00141560	7/12/2024	12.27
		Check PPS00141560:	12.27					
ONE TIME VENDOR	Pikepass	VO808605	14.02	PPS Refund - IAN A. DUNLAP	NTAGGART	PPS00141562	7/12/2024	14.02
		Check PPS00141562:	14.02					
ONE TIME VENDOR	Pikepass	VO808606	40.00	PPS Refund - SHIRLEY A. DUELLO	NTAGGART	PPS00141563	7/12/2024	40.00
		Check PPS00141563:	40.00					
ONE TIME VENDOR	Pikepass	VO808607	63.50	PPS Refund - DAVID GODFREY	NTAGGART	PPS00141564	7/12/2024	63.50
		Check PPS00141564:	63.50					
ONE TIME VENDOR	Pikepass	VO808608	21.20	PPS Refund - KENDRA L. BRITAIN	NTAGGART	PPS00141565	7/12/2024	21.20
		Check PPS00141565:	21.20					
ONE TIME VENDOR	Pikepass	VO808610	49.00	PPS Refund - SUSAN E. NELSON	NTAGGART	PPS00141566	7/12/2024	49.00
		Check PPS00141566:	49.00					
ONE TIME VENDOR	Pikepass	VO808611	127.45	PPS Refund - RICHARD E. ROBINSON	NTAGGART	PPS00141567	7/12/2024	127.45

Vendor Name	Fund Desc	Voucher NO.	Amt Applied	Description	Approver	Check No.	Date Paid	Amt Check
		Check PPS00141567:	127.45					
ONE TIME VENDOR	Pikepass	VO808612	23.00	PPS Refund - STEVE T. WOODEN	NTAGGART	PPS00141568	7/12/2024	23.00
		Check PPS00141568:	23.00					
ONE TIME VENDOR	Pikepass	VO808613	48.30	PPS Refund - EMELIE C. SCHLUETER	NTAGGART	PPS00141569	7/12/2024	48.30
		Check PPS00141569:	48.30					
ONE TIME VENDOR	Pikepass	VO808614	63.84	PPS Refund - JOHN E. PEARMAN	NTAGGART	PPS00141570	7/12/2024	63.84
		Check PPS00141570:	63.84					
ONE TIME VENDOR	Pikepass	VO808615	13.49	PPS Refund - MIKE M. DEIMUND	NTAGGART	PPS00141571	7/12/2024	13.49
		Check PPS00141571:	13.49					
ONE TIME VENDOR	Pikepass	VO808616	19.35	PPS Refund - TERRI A. MEYER	NTAGGART	PPS00141572	7/12/2024	19.35
		Check PPS00141572:	19.35					
ONE TIME VENDOR	Pikepass	VO808617	9.72	PPS Refund - HOLLY L. CHANDLER	NTAGGART	PPS00141573	7/12/2024	9.72
		Check PPS00141573:	9.72					
ONE TIME VENDOR	Pikepass	VO808618	39.34	PPS Refund - RAKESH GANDHI	NTAGGART	PPS00141574	7/12/2024	39.34
		Check PPS00141574:	39.34					
ONE TIME VENDOR	Pikepass	VO808619	2.80	PPS Refund - SANDRA L. MCDANIEL	NTAGGART	PPS00141575	7/12/2024	2.80
		Check PPS00141575:	2.80					
ONE TIME VENDOR	Pikepass	VO808620	32.50	PPS Refund - ROY D. BELL	NTAGGART	PPS00141576	7/12/2024	32.50
		Check PPS00141576:	32.50					
ONE TIME VENDOR	Pikepass	VO808621	0.23	PPS Refund - LINDSEY M. IRWIN	NTAGGART	PPS00141577	7/12/2024	0.23
		Check PPS00141577:	0.23					
ONE TIME VENDOR	Pikepass	VO808622	40.53	PPS Refund - CHAD W. MORRIS	NTAGGART	PPS00141578	7/12/2024	40.53
		Check PPS00141578:	40.53					
ONE TIME VENDOR	Pikepass	VO808623	42.06	PPS Refund - CELESTE A. LANIER	NTAGGART	PPS00141579	7/12/2024	42.06
		Check PPS00141579:	42.06					
ONE TIME VENDOR	Pikepass	VO808624	18.42	PPS Refund - JOHN J. BROWN	NTAGGART	PPS00141580	7/12/2024	18.42
		Check PPS00141580:	18.42					
ONE TIME VENDOR	Pikepass	VO808625	9.70	PPS Refund - STANISLAV PSHICHENKO	NTAGGART	PPS00141581	7/12/2024	9.70
		Check PPS00141581:	9.70					
ONE TIME VENDOR	Pikepass	VO808626	41.00	PPS Refund - MAIKAO VANG	NTAGGART	PPS00141582	7/12/2024	41.00
		Check PPS00141582:	41.00					
ONE TIME VENDOR	Pikepass	VO808627	22.20	PPS Refund - JIM R. NEFF	NTAGGART	PPS00141583	7/12/2024	22.20
		Check PPS00141583:	22.20					
ONE TIME VENDOR	Pikepass	VO808628	40.00	PPS Refund - CLAUDIO M. LOYOLA	NTAGGART	PPS00141584	7/12/2024	40.00
		Check PPS00141584:	40.00					
ONE TIME VENDOR	Pikepass	VO808629	0.74	PPS Refund - SHYLA D. NEHER	NTAGGART	PPS00141585	7/12/2024	0.74

Vendor Name	Fund Desc	Voucher NO.	Amt Applied	Description	Approver	Check No.	Date Paid	Amt Check
		Check PPS00141585:	0.74					
ONE TIME VENDOR	Pikepass	VO808630	40.00	PPS Refund - AVA MILLS	NTAGGART	PPS00141586	7/12/2024	40.00
		Check PPS00141586:	40.00					
ONE TIME VENDOR	Pikepass	VO808631	19.80	PPS Refund - DAVID L. TALLEY	NTAGGART	PPS00141587	7/12/2024	19.80
		Check PPS00141587:	19.80					
ONE TIME VENDOR	Pikepass	VO808632	22.10	PPS Refund - LIOR BEN-AROYA	NTAGGART	PPS00141588	7/12/2024	22.10
		Check PPS00141588:	22.10					
ONE TIME VENDOR	Pikepass	VO808633	27.50	PPS Refund - ROBERT BROWN	NTAGGART	PPS00141589	7/12/2024	27.50
		Check PPS00141589:	27.50					
ONE TIME VENDOR	Pikepass	VO778210	35.47	PPS Refund - KAY M. BLACK	NTAGGART	PPS00141590	7/15/2024	35.47
		Check PPS00141590:	35.47					
ONE TIME VENDOR	Pikepass	VO809136	47.92	PPS Refund - BEVERLY P. WILLIAMS	NTAGGART	PPS00141591	7/19/2024	47.92
		Check PPS00141591:	47.92					
ONE TIME VENDOR	Pikepass	VO809137	300.00	PPS Refund - PATRICK L. PATTERSON	NTAGGART	PPS00141592	7/19/2024	300.00
		Check PPS00141592:	300.00					
ONE TIME VENDOR	Pikepass	VO809138	14.20	PPS Refund - J A. GIBSON	NTAGGART	PPS00141593	7/19/2024	14.20
		Check PPS00141593:	14.20					
ONE TIME VENDOR	Pikepass	VO809139	1.02	PPS Refund - KATHRYN I. BRIGANCE	NTAGGART	PPS00141594	7/19/2024	1.02
		Check PPS00141594:	1.02					
ONE TIME VENDOR	Pikepass	VO809140	32.31	PPS Refund - PAULA J. LEWIS	NTAGGART	PPS00141595	7/19/2024	32.31
		Check PPS00141595:	32.31					
ONE TIME VENDOR	Pikepass	VO809141	21.63	PPS Refund - TODD F. BREWER	NTAGGART	PPS00141596	7/19/2024	21.63
		Check PPS00141596:	21.63					
ONE TIME VENDOR	Pikepass	VO809142	500.00	PPS Refund - ANDY T. NGUYEN	NTAGGART	PPS00141597	7/19/2024	500.00
		Check PPS00141597:	500.00					
ONE TIME VENDOR	Pikepass	VO809143	25.50	PPS Refund - NANCY A. MCBRIDE-BEICHLER	NTAGGART	PPS00141598	7/19/2024	25.50
		Check PPS00141598:	25.50					
ONE TIME VENDOR	Pikepass	VO809144	31.48	PPS Refund - MARJORIE L. COLLIER	NTAGGART	PPS00141599	7/19/2024	31.48
		Check PPS00141599:	31.48					
ONE TIME VENDOR	Pikepass	VO809145	300.00	PPS Refund - FRANCES A. JONES	NTAGGART	PPS00141600	7/19/2024	300.00
		Check PPS00141600:	300.00					
ONE TIME VENDOR	Pikepass	VO809146	91.70	PPS Refund - JOHN S. GALLOWAY	NTAGGART	PPS00141601	7/19/2024	91.70
		Check PPS00141601:	91.70					
ONE TIME VENDOR	Pikepass	VO809147	25.26	PPS Refund - JEFFERY J. WIENS	NTAGGART	PPS00141602	7/19/2024	25.26
		Check PPS00141602:	25.26					
ONE TIME VENDOR	Pikepass	VO809148	37.82	PPS Refund - JOSUE DUARTE	NTAGGART	PPS00141603	7/19/2024	37.82

Vendor Name	Fund Desc	Voucher NO.	Amt Applied	Description	Approver	Check No.	Date Paid	Amt Check
		Check PPS00141603:	37.82					
ONE TIME VENDOR	Pikepass	VO809149	5.00	PPS Refund - MIRIAM Y. DE LA ROSA	NTAGGART	PPS00141604	7/19/2024	5.00
		Check PPS00141604:	5.00					
ONE TIME VENDOR	Pikepass	VO809150	40.00	PPS Refund - CHANDRA L. ANDERSON	NTAGGART	PPS00141605	7/19/2024	40.00
		Check PPS00141605:	40.00					
ONE TIME VENDOR	Pikepass	VO809151	110.70	PPS Refund - EARL B. STARKEY	NTAGGART	PPS00141606	7/19/2024	110.70
		Check PPS00141606:	110.70					
ONE TIME VENDOR	Pikepass	VO809152	62.60	PPS Refund - JOSHUA T. WOODSON	NTAGGART	PPS00141607	7/19/2024	62.60
		Check PPS00141607:	62.60					
ONE TIME VENDOR	Pikepass	VO809153	191.27	PPS Refund - JEFF M. AUDIBERT	NTAGGART	PPS00141608	7/19/2024	191.27
		Check PPS00141608:	191.27					
ONE TIME VENDOR	Pikepass	VO809154	322.95	PPS Refund - TRACY L. HUBBS	NTAGGART	PPS00141609	7/19/2024	322.95
		Check PPS00141609:	322.95					
ONE TIME VENDOR	Pikepass	VO809155	2.25	PPS Refund - JIM FELLERS	NTAGGART	PPS00141610	7/19/2024	2.25
		Check PPS00141610:	2.25					
ONE TIME VENDOR	Pikepass	VO809156	44.62	PPS Refund - SUE COLLINS	NTAGGART	PPS00141611	7/19/2024	44.62
		Check PPS00141611:	44.62					
ONE TIME VENDOR	Pikepass	VO809157	21.85	PPS Refund - LAVONNA M. NELSON	NTAGGART	PPS00141612	7/19/2024	21.85
		Check PPS00141612:	21.85					
ONE TIME VENDOR	Pikepass	VO809158	105.75	PPS Refund - DANSCO MANUFACTURING INC	NTAGGART	PPS00141613	7/19/2024	105.75
		Check PPS00141613:	105.75					
ONE TIME VENDOR	Pikepass	VO809159	43.41	PPS Refund - ANTHONY O. MERCHANT	NTAGGART	PPS00141614	7/19/2024	43.41
		Check PPS00141614:	43.41					
ONE TIME VENDOR	Pikepass	VO809160	48.56	PPS Refund - DONNAGALE G. TATE	NTAGGART	PPS00141615	7/19/2024	48.56
		Check PPS00141615:	48.56					
ONE TIME VENDOR	Pikepass	VO809161	37.20	PPS Refund - WILLIAM A. SCOTT	NTAGGART	PPS00141616	7/19/2024	37.20
		Check PPS00141616:	37.20					
ONE TIME VENDOR	Pikepass	VO809162	28.89	PPS Refund - BRENDA HENSON	NTAGGART	PPS00141617	7/19/2024	28.89
		Check PPS00141617:	28.89					
ONE TIME VENDOR	Pikepass	VO809163	40.00	PPS Refund - ROBIN GRATTET	NTAGGART	PPS00141618	7/19/2024	40.00
		Check PPS00141618:	40.00					
ONE TIME VENDOR	Pikepass	VO809164	85.16	PPS Refund - THOMAS P. SHOUSE	NTAGGART	PPS00141619	7/19/2024	85.16
		Check PPS00141619:	85.16					
ONE TIME VENDOR	Pikepass	VO809165	35.25	PPS Refund - HOLLY DARRAH	NTAGGART	PPS00141620	7/19/2024	35.25
		Check PPS00141620:	35.25					
ONE TIME VENDOR	Pikepass	VO809166	1.45	PPS Refund - BRITNEY N. CARRIGER	NTAGGART	PPS00141621	7/19/2024	1.45

Vendor Name	Fund Desc	Voucher NO.	Amt Applied	Description	Approver	Check No.	Date Paid	Amt Check
		Check PPS00141621:	1.45					
ONE TIME VENDOR	Pikepass	VO809167	29.26	PPS Refund - JESSICA R. MORENO	NTAGGART	PPS00141622	7/19/2024	29.26
		Check PPS00141622:	29.26					
ONE TIME VENDOR	Pikepass	VO809168	9.82	PPS Refund - JARED N. TORP	NTAGGART	PPS00141623	7/19/2024	9.82
		Check PPS00141623:	9.82					
ONE TIME VENDOR	Pikepass	VO809169	119.19	PPS Refund - CELESTE C. HILL	NTAGGART	PPS00141624	7/19/2024	119.19
		Check PPS00141624:	119.19					
ONE TIME VENDOR	Pikepass	VO809170	12.60	PPS Refund - BRIAN ELAM	NTAGGART	PPS00141625	7/19/2024	12.60
		Check PPS00141625:	12.60					
ONE TIME VENDOR	Pikepass	VO809171	13.95	PPS Refund - ROBERT ROBINSON	NTAGGART	PPS00141626	7/19/2024	13.95
		Check PPS00141626:	13.95					
ONE TIME VENDOR	Pikepass	VO809172	13.35	PPS Refund - RICHARD B. HOLLOWELL	NTAGGART	PPS00141627	7/19/2024	13.35
		Check PPS00141627:	13.35					
ONE TIME VENDOR	Pikepass	VO809173	30.18	PPS Refund - DALE FERGUSON	NTAGGART	PPS00141628	7/19/2024	30.18
		Check PPS00141628:	30.18					
ONE TIME VENDOR	Pikepass	VO809174	43.29	PPS Refund - SEAN M. MULLEN	NTAGGART	PPS00141629	7/19/2024	43.29
		Check PPS00141629:	43.29					
ONE TIME VENDOR	Pikepass	VO809175	25.72	PPS Refund - DOUGLAS M. WILSON	NTAGGART	PPS00141630	7/19/2024	25.72
		Check PPS00141630:	25.72					
ONE TIME VENDOR	Pikepass	VO809176	45.95	PPS Refund - THOMAS D. BOWLING	NTAGGART	PPS00141631	7/19/2024	45.95
		Check PPS00141631:	45.95					
ONE TIME VENDOR	Pikepass	VO809177	42.65	PPS Refund - JESSICA L. CRAFT	NTAGGART	PPS00141632	7/19/2024	42.65
		Check PPS00141632:	42.65					
ONE TIME VENDOR	Pikepass	VO809178	10.90	PPS Refund - DONALD CHALUPNIK	NTAGGART	PPS00141633	7/19/2024	10.90
		Check PPS00141633:	10.90					
ONE TIME VENDOR	Pikepass	VO809179	47.38	PPS Refund - JAMES S. POWERS	NTAGGART	PPS00141634	7/19/2024	47.38
		Check PPS00141634:	47.38					
ONE TIME VENDOR	Pikepass	VO809180	13.95	PPS Refund - LANDON W. MINER	NTAGGART	PPS00141635	7/19/2024	13.95
		Check PPS00141635:	13.95					
ONE TIME VENDOR	Pikepass	VO809181	7.33	PPS Refund - JANICE KEENAN	NTAGGART	PPS00141636	7/19/2024	7.33
		Check PPS00141636:	7.33					
ONE TIME VENDOR	Pikepass	VO809182	39.70	PPS Refund - NANCY C. SHUFFIELD	NTAGGART	PPS00141637	7/19/2024	39.70
		Check PPS00141637:	39.70					
ONE TIME VENDOR	Pikepass	VO809183	23.46	PPS Refund - DESMOND SEE	NTAGGART	PPS00141638	7/19/2024	23.46
		Check PPS00141638:	23.46					
ONE TIME VENDOR	Pikepass	VO809184	54.80	PPS Refund - ROBERT S. IMOTICHEY	NTAGGART	PPS00141639	7/19/2024	54.80

Vendor Name	Fund Desc	Voucher NO.	Amt Applied	Description	Approver	Check No.	Date Paid	Amt Check
		Check PPS00141639:	54.80					
ONE TIME VENDOR	Pikepass	VO809185	19.15	PPS Refund - DARLA D. JOHNSON	NTAGGART	PPS00141640	7/19/2024	19.15
		Check PPS00141640:	19.15					
ONE TIME VENDOR	Pikepass	VO809186	61.04	PPS Refund - KYLE E. COONS	NTAGGART	PPS00141641	7/19/2024	61.04
		Check PPS00141641:	61.04					
ONE TIME VENDOR	Pikepass	VO809187	65.10	PPS Refund - LEVI V. SPRINGER	NTAGGART	PPS00141642	7/19/2024	65.10
		Check PPS00141642:	65.10					
ONE TIME VENDOR	Pikepass	VO809188	89.73	PPS Refund - ADINA SCHUTTE	NTAGGART	PPS00141643	7/19/2024	89.73
		Check PPS00141643:	89.73					
ONE TIME VENDOR	Pikepass	VO809189	13.70	PPS Refund - JERRY SMITH	NTAGGART	PPS00141644	7/19/2024	13.70
		Check PPS00141644:	13.70					
ONE TIME VENDOR	Pikepass	VO809190	21.64	PPS Refund - ACCELERATED TRUCKING & EXCA	NTAGGART	PPS00141645	7/19/2024	21.64
		Check PPS00141645:	21.64					
ONE TIME VENDOR	Pikepass	VO809191	40.00	PPS Refund - TANIA RODRIGUEZ-VILLATORO	NTAGGART	PPS00141646	7/19/2024	40.00
		Check PPS00141646:	40.00					
ONE TIME VENDOR	Pikepass	VO809192	32.45	PPS Refund - RONALD A. ZARSKI	NTAGGART	PPS00141647	7/19/2024	32.45
		Check PPS00141647:	32.45					
ONE TIME VENDOR	Pikepass	VO809193	46.90	PPS Refund - SHIRLEY G. WEDER	NTAGGART	PPS00141648	7/19/2024	46.90
		Check PPS00141648:	46.90					
ONE TIME VENDOR	Pikepass	VO809194	51.86	PPS Refund - JOHN P. CLARK	NTAGGART	PPS00141649	7/19/2024	51.86
		Check PPS00141649:	51.86					
ONE TIME VENDOR	Pikepass	VO809195	4.69	PPS Refund - SARAH B. VERNON	NTAGGART	PPS00141650	7/19/2024	4.69
		Check PPS00141650:	4.69					
ONE TIME VENDOR	Pikepass	VO809196	46.65	PPS Refund - JAMES F. HATFIELD	NTAGGART	PPS00141651	7/19/2024	46.65
		Check PPS00141651:	46.65					
ONE TIME VENDOR	Pikepass	VO809197	22.51	PPS Refund - TONY L. BUNCH	NTAGGART	PPS00141652	7/19/2024	22.51
		Check PPS00141652:	22.51					
ONE TIME VENDOR	Pikepass	VO809198	18.85	PPS Refund - GEORGIA A. MOON	NTAGGART	PPS00141653	7/19/2024	18.85
		Check PPS00141653:	18.85					
ONE TIME VENDOR	Pikepass	VO809199	38.04	PPS Refund - MARILYN J. SHATSWELL	NTAGGART	PPS00141654	7/19/2024	38.04
		Check PPS00141654:	38.04					
ONE TIME VENDOR	Pikepass	VO809200	52.04	PPS Refund - ALBERT L. LANATA	NTAGGART	PPS00141655	7/19/2024	52.04
		Check PPS00141655:	52.04					
ONE TIME VENDOR	Pikepass	VO809201	53.49	PPS Refund - JAMES R. KEENAN	NTAGGART	PPS00141656	7/19/2024	53.49
		Check PPS00141656:	53.49					
ONE TIME VENDOR	Pikepass	VO809202	20.53	PPS Refund - DARLENE G. GOOD	NTAGGART	PPS00141657	7/19/2024	20.53

Vendor Name	Fund Desc	Voucher NO.	Amt Applied	Description	Approver	Check No.	Date Paid	Amt Check
		Check PPS00141657:	20.53					
ONE TIME VENDOR	Pikepass	VO809203 Check PPS00141658:	77.71 77.71	PPS Refund - COURTNEY W. PITTS	NTAGGART	PPS00141658	7/19/2024	77.71
ONE TIME VENDOR	Pikepass	VO809204 Check PPS00141659:	54.91 54.91	PPS Refund - BRANDON J. YANDELL	NTAGGART	PPS00141659	7/19/2024	54.91
ONE TIME VENDOR	Pikepass	VO809205 Check PPS00141660:	51.00 51.00	PPS Refund - KARMEN RAPER	NTAGGART	PPS00141660	7/19/2024	51.00
ONE TIME VENDOR	Pikepass	VO809206 Check PPS00141661:	45.70 45.70	PPS Refund - ALAN ROWE	NTAGGART	PPS00141661	7/19/2024	45.70
ONE TIME VENDOR	Pikepass	VO809208 Check PPS00141663:	47.70 47.70	PPS Refund - JOSEPH C. COX	NTAGGART	PPS00141663	7/19/2024	47.70
ONE TIME VENDOR	Pikepass	VO809209 Check PPS00141664:	39.25 39.25	PPS Refund - VICTORIA PEREZ	NTAGGART	PPS00141664	7/19/2024	39.25
ONE TIME VENDOR	Pikepass	VO809210 Check PPS00141665:	33.00 33.00	PPS Refund - PENELOPE A. UMALI	NTAGGART	PPS00141665	7/19/2024	33.00
ONE TIME VENDOR	Pikepass	VO809211 Check PPS00141666:	14.31 14.31	PPS Refund - ABBEY C. PAUCKE	NTAGGART	PPS00141666	7/19/2024	14.31
ONE TIME VENDOR	Pikepass	VO809212 Check PPS00141667:	112.67 112.67	PPS Refund - LISA A. MINTER	NTAGGART	PPS00141667	7/19/2024	112.67
ONE TIME VENDOR	Pikepass	VO809213 Check PPS00141668:	360.95 360.95	PPS Refund - EARL HARDY TRUCKING	NTAGGART	PPS00141668	7/19/2024	360.95
ONE TIME VENDOR	Pikepass	VO809248 Check PPS00141669:	22.99 22.99	PPS Refund - ANDREW G. HARNESS	NTAGGART	PPS00141669	7/19/2024	22.99
ONE TIME VENDOR	Pikepass	VO809215 Check PPS00141670:	33.75 33.75	PPS Refund - TERRENCE A. CULLEN	NTAGGART	PPS00141670	7/19/2024	33.75
ONE TIME VENDOR	Pikepass	VO809216 Check PPS00141671:	50.10 50.10	PPS Refund - DON TETER	NTAGGART	PPS00141671	7/19/2024	50.10
ONE TIME VENDOR	Pikepass	VO809217 Check PPS00141672:	10.37 10.37	PPS Refund - JOSEPH G. DONOHUE	NTAGGART	PPS00141672	7/19/2024	10.37
ONE TIME VENDOR	Pikepass	VO809218 Check PPS00141673:	34.60 34.60	PPS Refund - BILLIE L. BAYOUTH	NTAGGART	PPS00141673	7/19/2024	34.60
ONE TIME VENDOR	Pikepass	VO809219 Check PPS00141674:	17.90 17.90	PPS Refund - LOCHLIN D. GOOLSBY	NTAGGART	PPS00141674	7/19/2024	17.90
ONE TIME VENDOR	Pikepass	VO809221 Check PPS00141676:	24.72 24.72	PPS Refund - DON R. GARRISON	NTAGGART	PPS00141676	7/19/2024	24.72
ONE TIME VENDOR	Pikepass	VO809222	28.70	PPS Refund - KENNETH ST CLAIR	NTAGGART	PPS00141677	7/19/2024	28.70



Vendor Name	Fund Desc	Voucher NO.	Amt Applied	Description	Approver	Check No.	Date Paid	Amt Check
		Check PPS00141677:	28.70					
ONE TIME VENDOR	Pikepass	VO809223	0.86	PPS Refund - CHRISTOPHER J. ODOM	NTAGGART	PPS00141678	7/19/2024	0.86
		Check PPS00141678:	0.86					
ONE TIME VENDOR	Pikepass	VO809224	18.45	PPS Refund - BERTHADEAN S. HOWARD	NTAGGART	PPS00141679	7/19/2024	18.45
		Check PPS00141679:	18.45					
ONE TIME VENDOR	Pikepass	VO809225	7,279.54	PPS Refund - SOUTHERN TIRE MART LLC	NTAGGART	PPS00141680	7/19/2024	7,279.54
		Check PPS00141680:	7,279.54					
ONE TIME VENDOR	Pikepass	VO809226	31.33	PPS Refund - EVANGELINE V. HOLMAN	NTAGGART	PPS00141681	7/19/2024	31.33
		Check PPS00141681:	31.33					
ONE TIME VENDOR	Pikepass	VO809227	17.48	PPS Refund - HARRIETT GARMS	NTAGGART	PPS00141682	7/19/2024	17.48
		Check PPS00141682:	17.48					
ONE TIME VENDOR	Pikepass	VO809228	48.32	PPS Refund - JOSEPH C. HEDGECOCK	NTAGGART	PPS00141683	7/19/2024	48.32
		Check PPS00141683:	48.32					
ONE TIME VENDOR	Pikepass	VO809229	1.80	PPS Refund - DANIEL H. HYLIA	NTAGGART	PPS00141684	7/19/2024	1.80
		Check PPS00141684:	1.80					
ONE TIME VENDOR	Pikepass	VO809230	28.18	PPS Refund - CAROLYN E. GOOLSBY	NTAGGART	PPS00141685	7/19/2024	28.18
		Check PPS00141685:	28.18					
ONE TIME VENDOR	Pikepass	VO809231	150.70	PPS Refund - KIMBERLEY A. BATES	NTAGGART	PPS00141686	7/19/2024	150.70
		Check PPS00141686:	150.70					
ONE TIME VENDOR	Pikepass	VO809232	20.00	PPS Refund - RUSSELL BROUSSARD	NTAGGART	PPS00141687	7/19/2024	20.00
		Check PPS00141687:	20.00					
ONE TIME VENDOR	Pikepass	VO809233	29.83	PPS Refund - VICKI D. LANIE	NTAGGART	PPS00141688	7/19/2024	29.83
		Check PPS00141688:	29.83					
ONE TIME VENDOR	Pikepass	VO809235	31.65	PPS Refund - JO ELLEN BEARD	NTAGGART	PPS00141690	7/19/2024	31.65
		Check PPS00141690:	31.65					
ONE TIME VENDOR	Pikepass	VO809236	5.02	PPS Refund - YIFEI HUANG	NTAGGART	PPS00141691	7/19/2024	5.02
		Check PPS00141691:	5.02					
ONE TIME VENDOR	Pikepass	VO809237	21.36	PPS Refund - JANET C. HANSON	NTAGGART	PPS00141692	7/19/2024	21.36
		Check PPS00141692:	21.36					
ONE TIME VENDOR	Pikepass	VO809238	9.76	PPS Refund - JOHN MERRYWEATHER	NTAGGART	PPS00141693	7/19/2024	9.76
		Check PPS00141693:	9.76					
ONE TIME VENDOR	Pikepass	VO809239	43.91	PPS Refund - TONY C. BELL	NTAGGART	PPS00141694	7/19/2024	43.91
		Check PPS00141694:	43.91					
ONE TIME VENDOR	Pikepass	VO809240	33.72	PPS Refund - JENNIFER WILLIAMS	NTAGGART	PPS00141695	7/19/2024	33.72
		Check PPS00141695:	33.72					
ONE TIME VENDOR	Pikepass	VO809241	44.08	PPS Refund - SHEKHAR RATHOR	NTAGGART	PPS00141696	7/19/2024	44.08

Vendor Name	Fund Desc	Voucher NO.	Amt Applied	Description	Approver	Check No.	Date Paid	Amt Check
		Check PPS00141696:	44.08					
ONE TIME VENDOR	Pikepass	VO809242	222.45	PPS Refund - MIDCON SERVICES, LLC.	NTAGGART	PPS00141697	7/19/2024	222.45
		Check PPS00141697:	222.45					
ONE TIME VENDOR	Pikepass	VO809243	9.40	PPS Refund - SARA M. HERNANDEZ	NTAGGART	PPS00141698	7/19/2024	9.40
		Check PPS00141698:	9.40					
ONE TIME VENDOR	Pikepass	VO809244	42.30	PPS Refund - ROBBIE WHITE	NTAGGART	PPS00141699	7/19/2024	42.30
		Check PPS00141699:	42.30					
ONE TIME VENDOR	Pikepass	VO809245	27.00	PPS Refund - JANE GAVIN	NTAGGART	PPS00141700	7/19/2024	27.00
		Check PPS00141700:	27.00					
ONE TIME VENDOR	Pikepass	VO809246	43.55	PPS Refund - CAMRYN J. POWELL	NTAGGART	PPS00141701	7/19/2024	43.55
		Check PPS00141701:	43.55					
ONE TIME VENDOR	Pikepass	VO809247	159.80	PPS Refund - RYLEIGH R. FISHER	NTAGGART	PPS00141702	7/19/2024	159.80
		Check PPS00141702:	159.80					
ONE TIME VENDOR	Pikepass	VO809705	11.35	PPS Refund - PAUL T. RITTER	NTAGGART	PPS00141703	7/26/2024	11.35
		Check PPS00141703:	11.35					
ONE TIME VENDOR	Pikepass	VO809706	27.80	PPS Refund - MARTIN F. DUPSLAFF	NTAGGART	PPS00141704	7/26/2024	27.80
		Check PPS00141704:	27.80					
ONE TIME VENDOR	Pikepass	VO809707	43.34	PPS Refund - JOHN J. POWELL	NTAGGART	PPS00141705	7/26/2024	43.34
		Check PPS00141705:	43.34					
ONE TIME VENDOR	Pikepass	VO809708	138.42	PPS Refund - KELL PRO COMPUTER SOLUTIONS	NTAGGART	PPS00141706	7/26/2024	138.42
		Check PPS00141706:	138.42					
ONE TIME VENDOR	Pikepass	VO809709	13.24	PPS Refund - BARBARA E. MARTIN	NTAGGART	PPS00141707	7/26/2024	13.24
		Check PPS00141707:	13.24					
ONE TIME VENDOR	Pikepass	VO809710	11.40	PPS Refund - JOHN F. NELSON	NTAGGART	PPS00141708	7/26/2024	11.40
		Check PPS00141708:	11.40					
ONE TIME VENDOR	Pikepass	VO809711	61.78	PPS Refund - JOHN CANTERBURY	NTAGGART	PPS00141709	7/26/2024	61.78
		Check PPS00141709:	61.78					
ONE TIME VENDOR	Pikepass	VO809712	24.35	PPS Refund - LEROY E. RADATZ	NTAGGART	PPS00141710	7/26/2024	24.35
		Check PPS00141710:	24.35					
ONE TIME VENDOR	Pikepass	VO809713	49.92	PPS Refund - JAMES GRAHAM	NTAGGART	PPS00141711	7/26/2024	49.92
		Check PPS00141711:	49.92					
ONE TIME VENDOR	Pikepass	VO809714	13.50	PPS Refund - CHRISTINE R. KLINGAMAN	NTAGGART	PPS00141712	7/26/2024	13.50
		Check PPS00141712:	13.50					
ONE TIME VENDOR	Pikepass	VO809715	41.12	PPS Refund - TRI STATE FIRE EXTINGUISHER	NTAGGART	PPS00141713	7/26/2024	41.12
		Check PPS00141713:	41.12					
ONE TIME VENDOR	Pikepass	VO809716	26.24	PPS Refund - MICHAEL J. DAVIS	NTAGGART	PPS00141714	7/26/2024	26.24

Vendor Name	Fund Desc	Voucher NO.	Amt Applied	Description	Approver	Check No.	Date Paid	Amt Check
		Check PPS00141714:	26.24					
ONE TIME VENDOR	Pikepass	VO809717	27.60	PPS Refund - ELLAMAE ROBINSON	NTAGGART	PPS00141715	7/26/2024	27.60
		Check PPS00141715:	27.60					
ONE TIME VENDOR	Pikepass	VO809718	11.79	PPS Refund - MATTHEW FRANKS	NTAGGART	PPS00141716	7/26/2024	11.79
		Check PPS00141716:	11.79					
ONE TIME VENDOR	Pikepass	VO809719	5.06	PPS Refund - FRANCIS D. JULIAN	NTAGGART	PPS00141717	7/26/2024	5.06
		Check PPS00141717:	5.06					
ONE TIME VENDOR	Pikepass	VO809720	34.48	PPS Refund - HENDERSONS HAY	NTAGGART	PPS00141718	7/26/2024	34.48
		Check PPS00141718:	34.48					
ONE TIME VENDOR	Pikepass	VO809721	43.70	PPS Refund - PATSY A. BRADLEY	NTAGGART	PPS00141719	7/26/2024	43.70
		Check PPS00141719:	43.70					
ONE TIME VENDOR	Pikepass	VO809722	33.71	PPS Refund - GEORGE E. HARTNETT	NTAGGART	PPS00141720	7/26/2024	33.71
		Check PPS00141720:	33.71					
ONE TIME VENDOR	Pikepass	VO809723	37.12	PPS Refund - MARY L. MURRAY	NTAGGART	PPS00141721	7/26/2024	37.12
		Check PPS00141721:	37.12					
ONE TIME VENDOR	Pikepass	VO809724	57.16	PPS Refund - A&D SUPPLY OF FT SMITH LLC	NTAGGART	PPS00141722	7/26/2024	57.16
		Check PPS00141722:	57.16					
ONE TIME VENDOR	Pikepass	VO809725	56.66	PPS Refund - DON A. FRANZ	NTAGGART	PPS00141723	7/26/2024	56.66
		Check PPS00141723:	56.66					
ONE TIME VENDOR	Pikepass	VO809726	36.90	PPS Refund - LATOSHA R. BRYANT	NTAGGART	PPS00141724	7/26/2024	36.90
		Check PPS00141724:	36.90					
ONE TIME VENDOR	Pikepass	VO809727	44.60	PPS Refund - RANDALL W. MORRIS	NTAGGART	PPS00141725	7/26/2024	44.60
		Check PPS00141725:	44.60					
ONE TIME VENDOR	Pikepass	VO809728	29.25	PPS Refund - PATRICIA A. SMITH	NTAGGART	PPS00141726	7/26/2024	29.25
		Check PPS00141726:	29.25					
ONE TIME VENDOR	Pikepass	VO809729	24.20	PPS Refund - CHARLES L. HIGGINS	NTAGGART	PPS00141727	7/26/2024	24.20
		Check PPS00141727:	24.20					
ONE TIME VENDOR	Pikepass	VO809730	17.91	PPS Refund - RONALD L. HIGGINS	NTAGGART	PPS00141728	7/26/2024	17.91
		Check PPS00141728:	17.91					
ONE TIME VENDOR	Pikepass	VO809731	27.15	PPS Refund - RYAN W. MORRISETT	NTAGGART	PPS00141729	7/26/2024	27.15
		Check PPS00141729:	27.15					
ONE TIME VENDOR	Pikepass	VO809732	24.30	PPS Refund - JESSICA J. NUNN	NTAGGART	PPS00141730	7/26/2024	24.30
		Check PPS00141730:	24.30					
ONE TIME VENDOR	Pikepass	VO809733	13.34	PPS Refund - JERRY E. PENDLETON	NTAGGART	PPS00141731	7/26/2024	13.34
		Check PPS00141731:	13.34					
ONE TIME VENDOR	Pikepass	VO809734	16.10	PPS Refund - RYAN K. SKELTON	NTAGGART	PPS00141732	7/26/2024	16.10

Vendor Name	Fund Desc	Voucher NO.	Amt Applied	Description	Approver	Check No.	Date Paid	Amt Check
		Check PPS00141732:	16.10					
ONE TIME VENDOR	Pikepass	VO809735	29.96	PPS Refund - ONDRAYA M. BROWN	NTAGGART	PPS00141733	7/26/2024	29.96
		Check PPS00141733:	29.96					
ONE TIME VENDOR	Pikepass	VO809736	38.23	PPS Refund - JUNIOR J. NATION	NTAGGART	PPS00141734	7/26/2024	38.23
		Check PPS00141734:	38.23					
ONE TIME VENDOR	Pikepass	VO809737	17.56	PPS Refund - TOM R. HESS	NTAGGART	PPS00141735	7/26/2024	17.56
		Check PPS00141735:	17.56					
ONE TIME VENDOR	Pikepass	VO809739	18.89	PPS Refund - CAROL A. SILING	NTAGGART	PPS00141737	7/26/2024	18.89
		Check PPS00141737:	18.89					
ONE TIME VENDOR	Pikepass	VO809740	29.15	PPS Refund - BEN A. WHITNEY	NTAGGART	PPS00141738	7/26/2024	29.15
		Check PPS00141738:	29.15					
ONE TIME VENDOR	Pikepass	VO809741	17.15	PPS Refund - MONA R. KEFFER	NTAGGART	PPS00141739	7/26/2024	17.15
		Check PPS00141739:	17.15					
ONE TIME VENDOR	Pikepass	VO809742	43.21	PPS Refund - LAVERTA L. MOORE	NTAGGART	PPS00141740	7/26/2024	43.21
		Check PPS00141740:	43.21					
ONE TIME VENDOR	Pikepass	VO809743	9.14	PPS Refund - DORTHA M. NAIL	NTAGGART	PPS00141741	7/26/2024	9.14
		Check PPS00141741:	9.14					
ONE TIME VENDOR	Pikepass	VO809744	33.67	PPS Refund - JOHNNY R. WYNNE	NTAGGART	PPS00141742	7/26/2024	33.67
		Check PPS00141742:	33.67					
ONE TIME VENDOR	Pikepass	VO809745	17.24	PPS Refund - JERRY W. POOL	NTAGGART	PPS00141743	7/26/2024	17.24
		Check PPS00141743:	17.24					
ONE TIME VENDOR	Pikepass	VO809746	14.48	PPS Refund - MARILYN A. JARVIS	NTAGGART	PPS00141744	7/26/2024	14.48
		Check PPS00141744:	14.48					
ONE TIME VENDOR	Pikepass	VO809747	38.69	PPS Refund - SARAH L. JEFFRIES	NTAGGART	PPS00141745	7/26/2024	38.69
		Check PPS00141745:	38.69					
ONE TIME VENDOR	Pikepass	VO809748	97.58	PPS Refund - TOMMY G. LAIDLEY	NTAGGART	PPS00141746	7/26/2024	97.58
		Check PPS00141746:	97.58					
ONE TIME VENDOR	Pikepass	VO809749	4.00	PPS Refund - JEFFREY B. BADLEY	NTAGGART	PPS00141747	7/26/2024	4.00
		Check PPS00141747:	4.00					
ONE TIME VENDOR	Pikepass	VO809750	12.76	PPS Refund - MARILYN F. HOEFFNER	NTAGGART	PPS00141748	7/26/2024	12.76
		Check PPS00141748:	12.76					
ONE TIME VENDOR	Pikepass	VO809751	34.25	PPS Refund - JEANNINE B. LONG	NTAGGART	PPS00141749	7/26/2024	34.25
		Check PPS00141749:	34.25					
ONE TIME VENDOR	Pikepass	VO809752	23.35	PPS Refund - CRANFILL K. WISDOM	NTAGGART	PPS00141750	7/26/2024	23.35
		Check PPS00141750:	23.35					
ONE TIME VENDOR	Pikepass	VO809753	43.70	PPS Refund - JOYCE E. REA	NTAGGART	PPS00141751	7/26/2024	43.70

Vendor Name	Fund Desc	Voucher NO.	Amt Applied	Description	Approver	Check No.	Date Paid	Amt Check
		Check PPS00141751:	43.70					
ONE TIME VENDOR	Pikepass	VO809754	47.80	PPS Refund - LAURIE L. FULLER	NTAGGART	PPS00141752	7/26/2024	47.80
		Check PPS00141752:	47.80					
ONE TIME VENDOR	Pikepass	VO809755	22.70	PPS Refund - RUTH MURRAY	NTAGGART	PPS00141753	7/26/2024	22.70
		Check PPS00141753:	22.70					
ONE TIME VENDOR	Pikepass	VO809756	37.92	PPS Refund - RUDY P. SCHUBERT	NTAGGART	PPS00141754	7/26/2024	37.92
		Check PPS00141754:	37.92					
ONE TIME VENDOR	Pikepass	VO809757	23.75	PPS Refund - TERRY GABLER	NTAGGART	PPS00141755	7/26/2024	23.75
		Check PPS00141755:	23.75					
ONE TIME VENDOR	Pikepass	VO809758	28.10	PPS Refund - CELIA GALLARDO	NTAGGART	PPS00141756	7/26/2024	28.10
		Check PPS00141756:	28.10					
ONE TIME VENDOR	Pikepass	VO809759	0.78	PPS Refund - MITCHELL D. MYERS	NTAGGART	PPS00141757	7/26/2024	0.78
		Check PPS00141757:	0.78					
ONE TIME VENDOR	Pikepass	VO809760	24.20	PPS Refund - JOHN W. SNYDER	NTAGGART	PPS00141758	7/26/2024	24.20
		Check PPS00141758:	24.20					
ONE TIME VENDOR	Pikepass	VO809761	727.90	PPS Refund - MARES TRUCKING LLC	NTAGGART	PPS00141759	7/26/2024	727.90
		Check PPS00141759:	727.90					
ONE TIME VENDOR	Pikepass	VO809762	25.15	PPS Refund - NATHAN F. HARDWICK	NTAGGART	PPS00141760	7/26/2024	25.15
		Check PPS00141760:	25.15					
ONE TIME VENDOR	Pikepass	VO809763	48.80	PPS Refund - KENT STRUBLE	NTAGGART	PPS00141761	7/26/2024	48.80
		Check PPS00141761:	48.80					
ONE TIME VENDOR	Pikepass	VO809764	32.45	PPS Refund - BRENT C. BEHRENS	NTAGGART	PPS00141762	7/26/2024	32.45
		Check PPS00141762:	32.45					
ONE TIME VENDOR	Pikepass	VO809765	3.05	PPS Refund - DAVID A. HERMANSKI	NTAGGART	PPS00141763	7/26/2024	3.05
		Check PPS00141763:	3.05					
ONE TIME VENDOR	Pikepass	VO809766	40.00	PPS Refund - SPENCER A. KALLOO-CRANE	NTAGGART	PPS00141764	7/26/2024	40.00
		Check PPS00141764:	40.00					
ONE TIME VENDOR	Pikepass	VO809767	9.71	PPS Refund - JERRY H. SWETLAND	NTAGGART	PPS00141765	7/26/2024	9.71
		Check PPS00141765:	9.71					
ONE TIME VENDOR	Pikepass	VO809768	38.00	PPS Refund - JACOB CLARK	NTAGGART	PPS00141766	7/26/2024	38.00
		Check PPS00141766:	38.00					
ONE TIME VENDOR	Pikepass	VO809769	31.35	PPS Refund - KYLE MILLER	NTAGGART	PPS00141767	7/26/2024	31.35
		Check PPS00141767:	31.35					
ONE TIME VENDOR	Pikepass	VO809770	41.90	PPS Refund - ARTHUR C. WOOD	NTAGGART	PPS00141768	7/26/2024	41.90
		Check PPS00141768:	41.90					
ONE TIME VENDOR	Pikepass	VO809771	36.91	PPS Refund - NADYNE BURRUSS	NTAGGART	PPS00141769	7/26/2024	36.91

Vendor Name	Fund Desc	Voucher NO.	Amt Applied	Description	Approver	Check No.	Date Paid	Amt Check
		Check PPS00141769:	36.91					
ONE TIME VENDOR	Pikepass	VO809772	52.40	PPS Refund - JAMES A. DUQUETTE	NTAGGART	PPS00141770	7/26/2024	52.40
		Check PPS00141770:	52.40					
ONE TIME VENDOR	Pikepass	VO809773	34.80	PPS Refund - ROBERT K. MARSON	NTAGGART	PPS00141771	7/26/2024	34.80
		Check PPS00141771:	34.80					
ONE TIME VENDOR	Pikepass	VO809774	21.60	PPS Refund - DONNA M. ELMORE	NTAGGART	PPS00141772	7/26/2024	21.60
		Check PPS00141772:	21.60					
ONE TIME VENDOR	Pikepass	VO809775	43.80	PPS Refund - TERRY THIESSEN	NTAGGART	PPS00141773	7/26/2024	43.80
		Check PPS00141773:	43.80					
ONE TIME VENDOR	Pikepass	VO809776	40.40	PPS Refund - RICHARD A. BARRETT	NTAGGART	PPS00141774	7/26/2024	40.40
		Check PPS00141774:	40.40					
ONE TIME VENDOR	Pikepass	VO809777	38.25	PPS Refund - SHELBY N. FIELDS	NTAGGART	PPS00141775	7/26/2024	38.25
		Check PPS00141775:	38.25					
ONE TIME VENDOR	Pikepass	VO809778	30.16	PPS Refund - SHERI A. ADAIR	NTAGGART	PPS00141776	7/26/2024	30.16
		Check PPS00141776:	30.16					
ONE TIME VENDOR	Pikepass	VO809779	34.03	PPS Refund - ANTHONY J. THOMPSON	NTAGGART	PPS00141777	7/26/2024	34.03
		Check PPS00141777:	34.03					
ONE TIME VENDOR	Pikepass	VO809780	47.15	PPS Refund - KYLE L. PUGH	NTAGGART	PPS00141778	7/26/2024	47.15
		Check PPS00141778:	47.15					
ONE TIME VENDOR	Pikepass	VO809781	68.10	PPS Refund - SHUJUN JIANG	NTAGGART	PPS00141779	7/26/2024	68.10
		Check PPS00141779:	68.10					
ONE TIME VENDOR	Pikepass	VO809782	28.85	PPS Refund - JANE N. LANDSBERGER	NTAGGART	PPS00141780	7/26/2024	28.85
		Check PPS00141780:	28.85					
ONE TIME VENDOR	Pikepass	VO809783	40.00	PPS Refund - CAROLE W. TERRY	NTAGGART	PPS00141781	7/26/2024	40.00
		Check PPS00141781:	40.00					
ONE TIME VENDOR	Pikepass	VO809784	38.10	PPS Refund - SHAMIKA S. VERDEJO	NTAGGART	PPS00141782	7/26/2024	38.10
		Check PPS00141782:	38.10					
ONE TIME VENDOR	Pikepass	VO809785	65.40	PPS Refund - JOSHUA ALCAZAR	NTAGGART	PPS00141783	7/26/2024	65.40
		Check PPS00141783:	65.40					
ONE TIME VENDOR	Pikepass	VO809786	27.85	PPS Refund - KYLE A. SMILANICH	NTAGGART	PPS00141784	7/26/2024	27.85
		Check PPS00141784:	27.85					
ONE TIME VENDOR	Pikepass	VO809787	34.90	PPS Refund - JAMES R. GERMAN	NTAGGART	PPS00141785	7/26/2024	34.90
		Check PPS00141785:	34.90					
ONE TIME VENDOR	Pikepass	VO809788	28.25	PPS Refund - MABEL THIESSEN	NTAGGART	PPS00141786	7/26/2024	28.25
		Check PPS00141786:	28.25					
ONE TIME VENDOR	Pikepass	VO809789	22.35	PPS Refund - SILVIA SUSANA ALVAN	NTAGGART	PPS00141787	7/26/2024	22.35

Vendor Name	Fund Desc	Voucher NO.	Amt Applied	Description	Approver	Check No.	Date Paid	Amt Check
		Check PPS00141787:	22.35					
ONE TIME VENDOR	Pikepass	VO809790	225.84	PPS Refund - SBS INDUSTRIES LLC	NTAGGART	PPS00141788	7/26/2024	225.84
		Check PPS00141788:	225.84					
ONE TIME VENDOR	Pikepass	VO809791	34.35	PPS Refund - DORIS E. MUSTAIN	NTAGGART	PPS00141789	7/26/2024	34.35
		Check PPS00141789:	34.35					
ONE TIME VENDOR	Pikepass	VO809792	20.06	PPS Refund - JERRY W. CASEY	NTAGGART	PPS00141790	7/26/2024	20.06
		Check PPS00141790:	20.06					
ONE TIME VENDOR	Pikepass	VO809793	13.50	PPS Refund - JANET J. GIRARD	NTAGGART	PPS00141791	7/26/2024	13.50
		Check PPS00141791:	13.50					
ONE TIME VENDOR	Pikepass	VO809794	191.93	PPS Refund - RICHARD G. LINDSAY	NTAGGART	PPS00141792	7/26/2024	191.93
		Check PPS00141792:	191.93					
ONE TIME VENDOR	Pikepass	VO809795	31.00	PPS Refund - FRANCES PASTERNIK	NTAGGART	PPS00141793	7/26/2024	31.00
		Check PPS00141793:	31.00					
ONE TIME VENDOR	Pikepass	VO809796	15.78	PPS Refund - CHAD A. COCHRAN	NTAGGART	PPS00141794	7/26/2024	15.78
		Check PPS00141794:	15.78					
ONE TIME VENDOR	Pikepass	VO809797	16.50	PPS Refund - KENNETH W. GIBSON	NTAGGART	PPS00141795	7/26/2024	16.50
		Check PPS00141795:	16.50					
ONE TIME VENDOR	Pikepass	VO809798	19.34	PPS Refund - THOMAS W. MYRICK	NTAGGART	PPS00141796	7/26/2024	19.34
		Check PPS00141796:	19.34					
ONE TIME VENDOR	Pikepass	VO809799	17.05	PPS Refund - JOHN C. MECHAN	NTAGGART	PPS00141797	7/26/2024	17.05
		Check PPS00141797:	17.05					
ONE TIME VENDOR	Pikepass	VO809800	25.20	PPS Refund - KEITH FALCON	NTAGGART	PPS00141798	7/26/2024	25.20
		Check PPS00141798:	25.20					
ONE TIME VENDOR	Pikepass	VO809801	9.64	PPS Refund - JEANNIE J. WOLVERTON	NTAGGART	PPS00141799	7/26/2024	9.64
		Check PPS00141799:	9.64					
ONE TIME VENDOR	Pikepass	VO809802	26.60	PPS Refund - LIDIA PAQUETTE	NTAGGART	PPS00141800	7/26/2024	26.60
		Check PPS00141800:	26.60					
ONE TIME VENDOR	Pikepass	VO809803	24.40	PPS Refund - GEORGE M. SMITH	NTAGGART	PPS00141801	7/26/2024	24.40
		Check PPS00141801:	24.40					
ONE TIME VENDOR	Pikepass	VO809804	27.06	PPS Refund - ANUJ SHRESTHA	NTAGGART	PPS00141802	7/26/2024	27.06
		Check PPS00141802:	27.06					
ONE TIME VENDOR	Pikepass	VO809805	107.69	PPS Refund - KATELYN N. CLIFTON	NTAGGART	PPS00141803	7/26/2024	107.69
		Check PPS00141803:	107.69					
ONE TIME VENDOR	Pikepass	VO809806	27.10	PPS Refund - DEBORAH E. ADKINS	NTAGGART	PPS00141804	7/26/2024	27.10
		Check PPS00141804:	27.10					
ONE TIME VENDOR	Pikepass	VO809807	14.77	PPS Refund - SAMUEL J. FLORES	NTAGGART	PPS00141805	7/26/2024	14.77

Vendor Name	Fund Desc	Voucher NO.	Amt Applied	Description	Approver	Check No.	Date Paid	Amt Check
		Check PPS00141805:	14.77					
ONE TIME VENDOR	Pikepass	VO809808	186.27	PPS Refund - COURTNEY F. WOOD	NTAGGART	PPS00141806	7/26/2024	186.27
		Check PPS00141806:	186.27					
ONE TIME VENDOR	Pikepass	VO809809	12.60	PPS Refund - JASON P. MILLER	NTAGGART	PPS00141807	7/26/2024	12.60
		Check PPS00141807:	12.60					
ONE TIME VENDOR	Pikepass	VO809810	38.30	PPS Refund - KAHLEN L. WISEMAN	NTAGGART	PPS00141808	7/26/2024	38.30
		Check PPS00141808:	38.30					
ONE TIME VENDOR	Pikepass	VO809811	36.50	PPS Refund - LYNDEN B. WHARRY	NTAGGART	PPS00141809	7/26/2024	36.50
		Check PPS00141809:	36.50					
ONE TIME VENDOR	Pikepass	VO809812	3.00	PPS Refund - JENNIFER GRAHAM	NTAGGART	PPS00141810	7/26/2024	3.00
		Check PPS00141810:	3.00					
ONE TIME VENDOR	Pikepass	VO809813	100.00	PPS Refund - CARISSA HEMPHILL	NTAGGART	PPS00141811	7/26/2024	100.00
		Check PPS00141811:	100.00					
ONE TIME VENDOR	Pikepass	VO809814	135.00	PPS Refund - ROBBY E. BILYEU	NTAGGART	PPS00141812	7/26/2024	135.00
		Check PPS00141812:	135.00					
ONE TIME VENDOR	Pikepass	VO809815	20.53	PPS Refund - ROSS W. LINCOLN	NTAGGART	PPS00141813	7/26/2024	20.53
		Check PPS00141813:	20.53					
ONE TIME VENDOR	Pikepass	VO809816	209.37	PPS Refund - FERGUSON ENTERPRISES INC	NTAGGART	PPS00141814	7/26/2024	209.37
		Check PPS00141814:	209.37					
ONE TIME VENDOR	Pikepass	VO809817	15.70	PPS Refund - JOYCE C. JONES	NTAGGART	PPS00141815	7/26/2024	15.70
		Check PPS00141815:	15.70					
ONE TIME VENDOR	Pikepass	VO809818	48.51	PPS Refund - JOHN K. WILLIAMS	NTAGGART	PPS00141816	7/26/2024	48.51
		Check PPS00141816:	48.51					
ONE TIME VENDOR	Pikepass	VO809819	41.81	PPS Refund - GARY W. ATKINS	NTAGGART	PPS00141817	7/26/2024	41.81
		Check PPS00141817:	41.81					
ONE TIME VENDOR	Pikepass	VO809820	12.45	PPS Refund - PAMELA H. DILLARD	NTAGGART	PPS00141818	7/26/2024	12.45
		Check PPS00141818:	12.45					
ONE TIME VENDOR	Pikepass	VO809821	15.03	PPS Refund - ALVIN F. JAN	NTAGGART	PPS00141819	7/26/2024	15.03
		Check PPS00141819:	15.03					
ONE TIME VENDOR	Pikepass	VO809822	51.94	PPS Refund - JOSE L. VAZQUEZ	NTAGGART	PPS00141820	7/26/2024	51.94
		Check PPS00141820:	51.94					
ONE TIME VENDOR	Pikepass	VO809823	40.70	PPS Refund - TONY L. YOUNG	NTAGGART	PPS00141821	7/26/2024	40.70
		Check PPS00141821:	40.70					
ONE TIME VENDOR	Pikepass	VO809824	4.76	PPS Refund - ANTHONY L. JOHNSON	NTAGGART	PPS00141822	7/26/2024	4.76
		Check PPS00141822:	4.76					
ONE TIME VENDOR	Pikepass	VO809825	31.05	PPS Refund - TIM J. CHAMPION	NTAGGART	PPS00141823	7/26/2024	31.05



Vendor Name	Fund Desc	Voucher NO.	Amt Applied	Description	Approver	Check No.	Date Paid	Amt Check
		Check PPS00141823:	31.05					
ONE TIME VENDOR	Pikepass	VO809826	13.65	PPS Refund - ROBERT L. JACKSON	NTAGGART	PPS00141824	7/26/2024	13.65
		Check PPS00141824:	13.65					
ONE TIME VENDOR	Pikepass	VO809827	41.30	PPS Refund - BRUCE L. DODSON	NTAGGART	PPS00141825	7/26/2024	41.30
		Check PPS00141825:	41.30					
ONE TIME VENDOR	Pikepass	VO809828	6.25	PPS Refund - LEONARD N. KREFT	NTAGGART	PPS00141826	7/26/2024	6.25
		Check PPS00141826:	6.25					
ONE TIME VENDOR	Pikepass	VO809829	24.60	PPS Refund - DERRICK E. DAVIS	NTAGGART	PPS00141827	7/26/2024	24.60
		Check PPS00141827:	24.60					
ONE TIME VENDOR	Pikepass	VO809830	6.50	PPS Refund - DEREK G. MARLAR	NTAGGART	PPS00141828	7/26/2024	6.50
		Check PPS00141828:	6.50					
ONE TIME VENDOR	Pikepass	VO809831	30.00	PPS Refund - MARILYN D. WALTON	NTAGGART	PPS00141829	7/26/2024	30.00
		Check PPS00141829:	30.00					
ONE TIME VENDOR	Pikepass	VO809832	35.53	PPS Refund - MITCHELL C. FREY	NTAGGART	PPS00141830	7/26/2024	35.53
		Check PPS00141830:	35.53					
ONE TIME VENDOR	Pikepass	VO809833	59.94	PPS Refund - RYAN L. BARRETT	NTAGGART	PPS00141831	7/26/2024	59.94
		Check PPS00141831:	59.94					
ONE TIME VENDOR	Pikepass	VO809834	42.61	PPS Refund - JUANITA SEPULVEDA	NTAGGART	PPS00141832	7/26/2024	42.61
		Check PPS00141832:	42.61					
ONE TIME VENDOR	Pikepass	VO809835	21.90	PPS Refund - MATTHIAS BENKERT	NTAGGART	PPS00141833	7/26/2024	21.90
		Check PPS00141833:	21.90					
ONE TIME VENDOR	Pikepass	VO809836	38.80	PPS Refund - MARGARET M. DAVIS	NTAGGART	PPS00141834	7/26/2024	38.80
		Check PPS00141834:	38.80					
ONE TIME VENDOR	Pikepass	VO809837	24.25	PPS Refund - DELRAE E. WILLIAMS	NTAGGART	PPS00141835	7/26/2024	24.25
		Check PPS00141835:	24.25					
ONE TIME VENDOR	Pikepass	VO809838	56.32	PPS Refund - CHERRY W. SNIDER	NTAGGART	PPS00141836	7/26/2024	56.32
		Check PPS00141836:	56.32					
ONE TIME VENDOR	Pikepass	VO809839	87.62	PPS Refund - EXPRESS REDI-MIX	NTAGGART	PPS00141837	7/26/2024	87.62
		Check PPS00141837:	87.62					
ONE TIME VENDOR	Pikepass	VO809840	30.45	PPS Refund - GULNUR UALIYEVA	NTAGGART	PPS00141838	7/26/2024	30.45
		Check PPS00141838:	30.45					
ONE TIME VENDOR	Pikepass	VO809841	27.45	PPS Refund - MERCEDES M. WILLIAMS	NTAGGART	PPS00141839	7/26/2024	27.45
		Check PPS00141839:	27.45					
ONE TIME VENDOR	Revenue Fund	VO807628	24.49	JULY 2024 EXPENSES	JSMITH	RRV00349235	7/2/2024	24.49
		Check RRV00349235:	24.49					
ONE TIME VENDOR	Revenue Fund	VO807629	87.32	JULY 2024 EXPENSES	JSMITH	RRV00349236	7/2/2024	87.32

Vendor Name	Fund Desc	Voucher NO.	Amt Applied	Description	Approver	Check No.	Date Paid	Amt Check
		Check RRV00349236:	87.32					
		<b>Total for ONE TIME VENDOR:</b>	<b>39,858.79</b>					
OOLOGAH TAG AGENCY - MARY WE	Revenue Fund	VO808255	27.50	FEE/ISSUANCE 11 PIKEPASS 06/2024	APERINGO	RRV00349562	7/10/2024	27.50
		Check RRV00349562:	27.50					
		<b>Total for OOLOGAH TAG AGENCY - MARY WEST:</b>	<b>27.50</b>					
ORCHID UNIFORM RETAIL SALES, LLC	Revenue Fund	VO807560	3,229.20	UNIFORMS	TJDILL	RRV00349217	7/2/2024	3,229.20
		Check RRV00349217:	3,229.20					
ORCHID UNIFORM RETAIL SALES, LLC	Revenue Fund	VO809508	2,824.00	SAFETY & MEDICAL SUPPLIES	SALLEN	RRV00349979	7/25/2024	5,927.12
		VO809506	813.12	SAFETY & MEDICAL SUPPLIES	PGOGGIN			
		VO809507	2,290.00	SAFETY & MEDICAL SUPPLIES	MCOLLINS			
		Check RRV00349979:	5,927.12					
		<b>Total for ORCHID UNIFORM RETAIL SALES, LLC:</b>	<b>9,156.32</b>					
ORKIN-TULSA	Revenue Fund	VO809545	43.36	PEST CONTROL SERVICES	JSMITH	RRV00349993	7/25/2024	43.36
		Check RRV00349993:	43.36					
		<b>Total for ORKIN-TULSA:</b>	<b>43.36</b>					
OSAGE TAG AGENCY	Revenue Fund	VO808256	85.00	FEE/ISSUANCE 34 PIKEPASS 06/2024	APERINGO	RRV00349563	7/10/2024	85.00
		Check RRV00349563:	85.00					
		<b>Total for OSAGE TAG AGENCY:</b>	<b>85.00</b>					
OTIS ELEVATOR COMPANY, INC.	Revenue Fund	VO807581	3,584.16	OTHER MAINTENANCE	TGORE	RRV00349211	7/2/2024	3,584.16
		Check RRV00349211:	3,584.16					
		<b>Total for OTIS ELEVATOR COMPANY, INC.:</b>	<b>3,584.16</b>					
OVERHEAD DOOR COMPANY OF STII	Revenue Fund	VO807609	683.50	BUILD MAINT SUPPLIES; BUILD MAINT SERV	RROWEN	RRV00349222	7/2/2024	683.50
		Check RRV00349222:	683.50					
		<b>Total for OVERHEAD DOOR COMPANY OF STILLWATER:</b>	<b>683.50</b>					
OWASSO TAG AGENCY	Revenue Fund	VO808257	380.00	FEE/ISSUANCE 152 PIKEPASS 06/2024	APERINGO	RRV00349564	7/10/2024	380.00
		Check RRV00349564:	380.00					
		<b>Total for OWASSO TAG AGENCY:</b>	<b>380.00</b>					
OZARK TRAIL MOTEL	Revenue Fund	VO808258	22.50	FEE/ISSUANCE 9 PIKEPASS 06/2024	APERINGO	RRV00349565	7/10/2024	22.50
		Check RRV00349565:	22.50					
		<b>Total for OZARK TRAIL MOTEL:</b>	<b>22.50</b>					
P & K EQUIPMENT	Revenue Fund	VO808110	214.96	EQUIPMENT PARTS AND SUPPLIES	BCANTREL	RRV00349410	7/9/2024	214.96
		Check RRV00349410:	214.96					
P & K EQUIPMENT	Revenue Fund	VO809092	61.33	EQUIPMENT PARTS AND SUPPLIES	BCANTREL	RRV00349863	7/18/2024	61.33
		Check RRV00349863:	61.33					
P & K EQUIPMENT	Revenue Fund	VO810038	216.16	EQUIPMENT PARTS AND SUPPLIES	BCANTREL	RRV00350086	7/29/2024	249.52
		VO810040	33.36	EQUIPMENT PARTS AND SUPPLIES	BCANTREL			
		Check RRV00350086:	249.52					
		<b>Total for P &amp; K EQUIPMENT:</b>	<b>525.81</b>					
P & K EQUIPMENT - MCALESTER	Revenue Fund	VO809085	149.94	EQUIPMENT PARTS AND SUPPLIES	BELLIS	RRV00349864	7/18/2024	149.94
		Check RRV00349864:	149.94					

Vendor Name	Fund Desc	Voucher NO.	Amt Applied	Description	Approver	Check No.	Date Paid	Amt Check
P & K EQUIPMENT - MCALESTER	Revenue Fund	VO809548	38.00	EQUIPMENT PARTS AND SUPPLIES	BWESTER	RRV00349995	7/25/2024	446.34
		VO809551	408.34	EQUIPMENT PARTS AND SUPPLIES	BWESTER			
		Check RRV00349995:	446.34					
		<b>Total for P &amp; K EQUIPMENT - MCALESTER:</b>	<b>596.28</b>					
P & K EQUIPMENT, INC.	Revenue Fund	VO809093	23.46	EQUIPMENT PARTS AND SUPPLIES	RROWEN	RRV00349860	7/18/2024	104.54
		VO809087	81.08	EQUIPMENT PARTS AND SUPPLIES	RROWEN			
		Check RRV00349860:	104.54					
		<b>Total for P &amp; K EQUIPMENT, INC.:</b>	<b>104.54</b>					
P & K EQUIPMENT, INC. - EDMOND	Revenue Fund	VO807604	121.00	EQUIPMENT PARTS AND SUPPLIES	PGOGGIN	RRV00349223	7/2/2024	4,453.56
		VO807590	82.56	EQUIPMENT PARTS AND SUPPLIES	RDTAYLOR			
		VO807593	4,250.00	EQUIPMENT PARTS AND SUPPLIES	SALLEN			
		Check RRV00349223:	4,453.56					
P & K EQUIPMENT, INC. - EDMOND	Revenue Fund	VO808109	139.12	EQUIPMENT PARTS AND SUPPLIES	PGOGGIN	RRV00349408	7/9/2024	139.12
		Check RRV00349408:	139.12					
P & K EQUIPMENT, INC. - EDMOND	Revenue Fund	VO809090	40.25	EQUIPMENT PARTS AND SUPPLIES	PGOGGIN	RRV00349861	7/18/2024	309.77
		VO809091	176.91	EQUIPMENT PARTS AND SUPPLIES	PGOGGIN			
		VO809089	92.61	EQUIPMENT PARTS AND SUPPLIES	PGOGGIN			
		Check RRV00349861:	309.77					
P & K EQUIPMENT, INC. - EDMOND	Revenue Fund	VO809565	138.96	EQUIPMENT PARTS AND SUPPLIES	PGOGGIN	RRV00349994	7/25/2024	138.96
		Check RRV00349994:	138.96					
P & K EQUIPMENT, INC. - EDMOND	Revenue Fund	VO810036	683.77	EQUIPMENT PARTS AND SUPPLIES	PGOGGIN	RRV00350084	7/29/2024	735.11
		VO810035	51.34	EQUIPMENT PARTS AND SUPPLIES	PGOGGIN			
		Check RRV00350084:	735.11					
		<b>Total for P &amp; K EQUIPMENT, INC. - EDMOND:</b>	<b>5,776.52</b>					
P & K EQUIPMENT, INC. - OWASSO	Revenue Fund	VO807585	31.47	EQUIPMENT PARTS AND SUPPLIES	JJENKINS	RRV00349224	7/2/2024	571.35
		VO807582	332.53	HARDWARE; EQUIPMENT PARTS	JJENKINS			
		VO807586	96.56	EQUIPMENT PARTS AND SUPPLIES	JJENKINS			
		VO807599	110.79	EQUIPMENT PARTS AND SUPPLIES	RDTAYLOR			
		Check RRV00349224:	571.35					
P & K EQUIPMENT, INC. - OWASSO	Revenue Fund	VO808106	366.75	EQUIPMENT PARTS AND SUPPLIES	JJENKINS	RRV00349409	7/9/2024	393.31
		VO808105	26.56	EQUIPMENT PARTS; HARDWARE	JJENKINS			
		Check RRV00349409:	393.31					
P & K EQUIPMENT, INC. - OWASSO	Revenue Fund	VO809086	55.96	EQUIPMENT PARTS AND SUPPLIES	JJENKINS	RRV00349862	7/18/2024	55.96
		Check RRV00349862:	55.96					
P & K EQUIPMENT, INC. - OWASSO	Revenue Fund	VO810033	153.29	EQUIPMENT PARTS AND SUPPLIES	DCRAIG	RRV00350085	7/29/2024	153.29
		Check RRV00350085:	153.29					
		<b>Total for P &amp; K EQUIPMENT, INC. - OWASSO:</b>	<b>1,173.91</b>					
P & K EQUIPMENT, INC. - PRYOR	Revenue Fund	VO807588	75.94	EQUIPMENT PARTS AND SUPPLIES	DCRAIG	RRV00349456	7/9/2024	563.54
		VO808128	487.60	EQUIPMENT PARTS AND SUPPLIES	CHUGHES			
		Check RRV00349456:	563.54					
P & K EQUIPMENT, INC. - PRYOR	Revenue Fund	VO810034	122.75	EQUIPMENT PARTS AND SUPPLIES	DCRAIG	RRV00350087	7/29/2024	122.75
		Check RRV00350087:	122.75					

Vendor Name	Fund Desc	Voucher NO.	Amt Applied	Description	Approver	Check No.	Date Paid	Amt Check
<b>Total for P &amp; K EQUIPMENT, INC. - PRYOR:</b>			<b>686.29</b>					
P & M WRECKER	Revenue Fund	VO809095	50.00	EQUIPMENT REPAIR	CSTEVENS	RRV00349866	7/18/2024	50.00
		Check RRV00349866:	50.00					
<b>Total for P &amp; M WRECKER:</b>			<b>50.00</b>					
P & T ENTERPRISES	Revenue Fund	VO807557	53.43	VEHICLE PARTS AND SUPPLIES	RROWEN	RRV00349227	7/2/2024	53.43
		Check RRV00349227:	53.43					
P & T ENTERPRISES	Revenue Fund	VO808910	378.49	EQUIPMENT PARTS AND SUPPLIES	RROWEN	RRV00349852	7/18/2024	696.63
		VO808916	181.98	VEHICLE PARTS AND SUPPLIES	RROWEN			
		VO808912	54.08	VEHICLE PARTS AND SUPPLIES	RROWEN			
		VO808914	82.08	VEHICLE PARTS AND SUPPLIES	RROWEN			
		Check RRV00349852:	696.63					
P & T ENTERPRISES	Revenue Fund	VO809980	206.07	VEHICLE PARTS AND SUPPLIES	RROWEN	RRV00350089	7/29/2024	465.92
		VO809981	-62.75	CREDIT-VEHICLE PARTS AND SUPPLIES	RROWEN			
		VO809977	199.99	VEHICLE PARTS AND SUPPLIES	RROWEN			
		VO809982	122.61	VEHICLE PARTS AND SUPPLIES	RROWEN			
		Check RRV00350089:	465.92					
<b>Total for P &amp; T ENTERPRISES:</b>			<b>1,215.98</b>					
P&K EQUIPMENT INC. - CHICKASHA	Revenue Fund	VO807606	440.68	EQUIPMENT PARTS; EQUIPMENT REPAIR	KWALLIS	RRV00349226	7/2/2024	656.78
		VO807607	32.03	EQUIPMENT PARTS AND SUPPLIES	KWALLIS			
		VO807608	184.07	EQUIPMENT PARTS AND SUPPLIES	KWALLIS			
		Check RRV00349226:	656.78					
P&K EQUIPMENT INC. - CHICKASHA	Revenue Fund	VO808112	82.25	EQUIPMENT PARTS AND SUPPLIES	KWALLIS	RRV00349411	7/9/2024	82.25
		Check RRV00349411:	82.25					
P&K EQUIPMENT INC. - CHICKASHA	Revenue Fund	VO809014	66.60	EQUIPMENT PARTS & SUPPLIES	KWALLIS	RRV00349829	7/17/2024	275.46
		VO809015	208.86	EQUIPMENT PARTS & SUPPLIES	KWALLIS			
		Check RRV00349829:	275.46					
P&K EQUIPMENT INC. - CHICKASHA	Revenue Fund	VO809566	653.56	EQUIPMENT PARTS AND SUPPLIES	KWALLIS	RRV00349996	7/25/2024	653.56
		Check RRV00349996:	653.56					
P&K EQUIPMENT INC. - CHICKASHA	Revenue Fund	VO810041	274.76	EQUIPMENT PARTS AND SUPPLIES	KWALLIS	RRV00350088	7/29/2024	274.76
		Check RRV00350088:	274.76					
<b>Total for P&amp;K EQUIPMENT INC. - CHICKASHA:</b>			<b>1,942.81</b>					
PACE HEAT & AIR	Revenue Fund	VO810056	5,350.00	BULDING MAINTENANCE SERVICES	MCOLLINS	RRV00350094	7/31/2024	5,350.00
		Check RRV00350094:	5,350.00					
<b>Total for PACE HEAT &amp; AIR:</b>			<b>5,350.00</b>					
PALFINGER USA, LLC	Revenue Fund	VO808911	45.11	EQUIPMENT PARTS	JJENKINS	RRV00349785	7/17/2024	45.11
		Check RRV00349785:	45.11					
<b>Total for PALFINGER USA, LLC:</b>			<b>45.11</b>					
PARTS CITY LTE, LLC	Revenue Fund	VO808261	55.00	FEE/ISSUANCE 22 PIKEPASS 06/2024	APERINGO	RRV00349566	7/10/2024	55.00
		Check RRV00349566:	55.00					
PARTS CITY LTE, LLC	Revenue Fund	VO809096	150.43	EQUIPMENT PARTS AND SUPPLIES	CHUGHES	RRV00349859	7/18/2024	207.19
		VO809097	56.76	EQUIPMENT PARTS AND SUPPLIES	CHUGHES			

Vendor Name	Fund Desc	Voucher NO.	Amt Applied	Description	Approver	Check No.	Date Paid	Amt Check
		Check RRV00349859:	<u>207.19</u>					
		<b>Total for PARTS CITY LTE, LLC:</b>	<b>262.19</b>					
PATCO ELECTRICAL SERVICES, INC.	Revenue Fund	VO807219	594.70	BUILD MAINT SERV; BUILD MAINT SUPP	TGORE	RRV00349239	7/2/2024	2,634.16
		VO807221	194.46	OTHER CONTRACTUAL SERVICES	TGORE			
		VO807220	205.00	OTHER CONTRACTUAL SERVICES	TGORE			
		VO807633	1,640.00	OTHER CONTRACTUAL SERVICES	TGORE			
		Check RRV00349239:	<u>2,634.16</u>					
		<b>Total for PATCO ELECTRICAL SERVICES, INC.:</b>	<b>2,634.16</b>					
PATE INDUSTRIAL SUPPLY, INC.	Revenue Fund	VO810058	56.37	EQUIPMENT PARTS AND SUPPLIES	BCANTREL	RRV00350095	7/31/2024	56.37
		Check RRV00350095:	<u>56.37</u>					
		<b>Total for PATE INDUSTRIAL SUPPLY, INC.:</b>	<b>56.37</b>					
PAULS VALLEY TAG AGENCY	Revenue Fund	VO808262	35.00	FEE/ISSUANCE 14 PIKEPASS 06/2024	APERINGO	RRV00349567	7/10/2024	35.00
		Check RRV00349567:	<u>35.00</u>					
		<b>Total for PAULS VALLEY TAG AGENCY:</b>	<b>35.00</b>					
PAWHUSKA TAG OFFICE	Revenue Fund	VO808280	22.50	FEE/ISSUANCE 9 PIKEPASS 06/2024	APERINGO	RRV00349569	7/11/2024	22.50
		Check RRV00349569:	<u>22.50</u>					
		<b>Total for PAWHUSKA TAG OFFICE:</b>	<b>22.50</b>					
PAWNEE TAG AGENCY - 5912	Revenue Fund	VO808281	35.00	FEE/ISSUANCE 14 PIKEPASS 06/2024	APERINGO	RRV00349568	7/11/2024	35.00
		Check RRV00349568:	<u>35.00</u>					
		<b>Total for PAWNEE TAG AGENCY - 5912:</b>	<b>35.00</b>					
PENN GLASS COMPANY LLC	Revenue Fund	VO808282	42.50	FEE/ISSUANCE 17 PIKEPASS 06/2024	APERINGO	RRV00349570	7/11/2024	42.50
		Check RRV00349570:	<u>42.50</u>					
		<b>Total for PENN GLASS COMPANY LLC:</b>	<b>42.50</b>					
PEOPLES ELECTRIC COOPERATIVE	Revenue Fund	VO807708	705.52	ELECTRIC	BPATTERS	EFT018759	7/5/2024	705.52
		Check EFT018759:	<u>705.52</u>					
		<b>Total for PEOPLES ELECTRIC COOPERATIVE:</b>	<b>705.52</b>					
PERKINS TAG AGENCY #6018	Revenue Fund	VO808283	115.00	FEE/ISSUANCE 46 PIKEPASS 06/2024	APERINGO	RRV00349571	7/11/2024	115.00
		Check RRV00349571:	<u>115.00</u>					
		<b>Total for PERKINS TAG AGENCY #6018:</b>	<b>115.00</b>					
PERRY TAG AGENCY #5215	Revenue Fund	VO808284	17.50	FEE/ISSUANCE 7 PIKEPASS 06/2024	APERINGO	RRV00349572	7/11/2024	17.50
		Check RRV00349572:	<u>17.50</u>					
		<b>Total for PERRY TAG AGENCY #5215:</b>	<b>17.50</b>					
PETTY'S COMMUNITY HARDWARE	Revenue Fund	VO809505	63.26	SMALL TOOLS & EQUIPMENT PARTS/SUPPLIES	JSMART	RRV00349958	7/24/2024	96.90
		VO809497	24.65	SMALL TOOLS & EQUIPMENT PARTS	JSMART			
		VO809500	8.99	EQUIPMENT PARTS & SUPPLIES	JSMART			
		Check RRV00349958:	<u>96.90</u>					
PETTY'S COMMUNITY HARDWARE	Revenue Fund	VO809998	5.60	HARDWARE	JSMART	RRV00350127	7/31/2024	5.60
		Check RRV00350127:	<u>5.60</u>					
		<b>Total for PETTY'S COMMUNITY HARDWARE:</b>	<b>102.50</b>					
PINNACLE BUSINESS SYSTEMS, INC.	Revenue Fund	VO809038	155,930.00	OTHER IT MAINTENANCE ; 307482	JP4JECH	REV00016052	7/18/2024	155,930.00
		Check REV00016052:	<u>155,930.00</u>					
		<b>Total for PINNACLE BUSINESS SYSTEMS, INC.:</b>	<b>155,930.00</b>					

Vendor Name	Fund Desc	Voucher NO.	Amt Applied	Description	Approver	Check No.	Date Paid	Amt Check																																																																																																																																																																																																														
PLANK AUTO SUPPLY INC.	Revenue Fund	VO807611	<u>360.00</u>	VEHICLE PARTS AND SUPPLIES	RDTAYLOR	RRV00349383	7/9/2024	360.00																																																																																																																																																																																																														
		Check RRV00349383:	360.00						PLANK AUTO SUPPLY INC.	Revenue Fund	VO809099	-15.24	CREDIT INVOICE-VEHICLE PARTS AND SUPPLIE	RDTAYLOR	RRV00349865	7/18/2024	762.96	VO809098	518.65	VEHICLE PARTS AND SUPPLIES	RDTAYLOR	VO809101	150.35	VEHICLE PARTS; SMALL TOOLS	RDTAYLOR	VO809102	<u>109.20</u>	VEHICLE PARTS; SAFETY; PAINTING	RDTAYLOR	Check RRV00349865:	762.96		PLANK AUTO SUPPLY INC.	Revenue Fund	VO809564	43.46	SAFETY & MEDICAL SUPPLIES	RDTAYLOR	RRV00350010	7/25/2024	724.47	VO809567	55.32	VEHICLE PART AND SUPPLIES	RDTAYLOR	VO809573	113.43	VEHICLE PARTS AND SUPPLIES	RDTAYLOR	VO809574	419.99	SMALL TOOLS & EQUIP	RDTAYLOR	VO809571	-3.14	CREDIT-VEHICLE PARTS AND SUPPLIES	RDTAYLOR	VO809575	<u>95.41</u>	VEHICLE PARTS & SUPPLIES	RDTAYLOR	Check RRV00350010:	724.47		PLANK AUTO SUPPLY INC.	Revenue Fund	VO810060	<u>59.35</u>	VEHICLE PARTS AND SUPPLIES	RDTAYLOR	RRV00350096	7/31/2024	59.35	Check RRV00350096:	59.35		<b>Total for PLANK AUTO SUPPLY INC.:</b>	<b>1,906.78</b>		POE & ASSOCIATES, INC.	Capital Projects	VO808808	<u>455,671.65</u>	PM-0101: PRGRM MGMT: SP-65: # 51426	TJD4JECH	23A0000227	7/15/2024	455,671.65	Check 23A0000227:	455,671.65		POE & ASSOCIATES, INC.	Capital Projects	VO808997	<u>1,200.00</u>	SP-66: T-26701A: AA-001: APRSL RVW:51367	TJDILL	23A0000233	7/18/2024	1,200.00	Check 23A0000233:	1,200.00		POE & ASSOCIATES, INC.	Capital Projects	VO810049	44,425.00	PM-0101: EWC-28801A: ROW OVRSGT: 51481	TGORE	23A0000250	7/30/2024	50,425.00	VO810094	<u>6,000.00</u>	EWC-28001: AA-003-009: AP RVW: 51480	TGORE	Check 23A0000250:	50,425.00		POE & ASSOCIATES, INC.	General	VO808971	2,987.50	AET-002: MU TP: RES ENG/MILEAGE: 51442	LNELSON	GEN00021489	7/17/2024	76,393.56	VO808963	9,065.00	SP-59: OVRLL PRGM MGMT: INV# 51330	BMANHALT	VO808966	1,655.00	SP-59: GILC EXPRSWY/DATA TRANSF: 51331	BMANHALT	VO808972	46,457.40	AET-004: IND TP: RES ENG/MILE/TST: 51444	TJDILL	VO808973	<u>16,228.66</u>	AET-001: CIM TP: RES ENG/MILE/: 51441	TJDILL	Check GEN00021489:	76,393.56		POE & ASSOCIATES, INC.	General	VO809864	<u>1,350.00</u>	SP-59: OVRLL PRGM MGMT: 51435	BMANHALT	GEN00021528	7/26/2024	1,350.00	Check GEN00021528:	1,350.00		<b>Total for POE &amp; ASSOCIATES, INC.:</b>	<b>585,040.21</b>		PONCA CITY TAG OFFICE - 3617	Revenue Fund	VO808285	<u>152.50</u>	FEE/ISSUANCE 61 PIKEPASS 06/2024	APERINGO	RRV00349573	7/11/2024	152.50	Check RRV00349573:	152.50		<b>Total for PONCA CITY TAG OFFICE - 3617:</b>			<b>152.50</b>						PORTER PUBLIC WORKS AUTHORITY	Revenue Fund	VO807463	49.13	ACCT#692 BULK WATER	BPATTERS	RRV00349162	7/1/2024	111.92	VO807462	<u>62.79</u>	ACCT#508 MUSKOGEE MAINT	BPATTERS	Check RRV00349162:	111.92		<b>Total for PORTER PUBLIC WORKS AUTHORITY:</b>			<b>111.92</b>						POSTAL ANNEX #18024	Revenue Fund	VO808286	<u>17.50</u>	FEE/ISSUANCE 7 PIKEPASS 06/2024	APERINGO
PLANK AUTO SUPPLY INC.	Revenue Fund	VO809099	-15.24	CREDIT INVOICE-VEHICLE PARTS AND SUPPLIE	RDTAYLOR	RRV00349865	7/18/2024	762.96																																																																																																																																																																																																														
		VO809098	518.65	VEHICLE PARTS AND SUPPLIES	RDTAYLOR																																																																																																																																																																																																																	
		VO809101	150.35	VEHICLE PARTS; SMALL TOOLS	RDTAYLOR																																																																																																																																																																																																																	
		VO809102	<u>109.20</u>	VEHICLE PARTS; SAFETY; PAINTING	RDTAYLOR																																																																																																																																																																																																																	
		Check RRV00349865:	762.96		PLANK AUTO SUPPLY INC.				Revenue Fund	VO809564	43.46	SAFETY & MEDICAL SUPPLIES	RDTAYLOR	RRV00350010	7/25/2024	724.47	VO809567	55.32	VEHICLE PART AND SUPPLIES	RDTAYLOR	VO809573	113.43	VEHICLE PARTS AND SUPPLIES	RDTAYLOR	VO809574	419.99	SMALL TOOLS & EQUIP	RDTAYLOR	VO809571	-3.14	CREDIT-VEHICLE PARTS AND SUPPLIES	RDTAYLOR			VO809575	<u>95.41</u>	VEHICLE PARTS & SUPPLIES	RDTAYLOR				Check RRV00350010:	724.47		PLANK AUTO SUPPLY INC.	Revenue Fund	VO810060	<u>59.35</u>	VEHICLE PARTS AND SUPPLIES	RDTAYLOR	RRV00350096	7/31/2024	59.35	Check RRV00350096:	59.35		<b>Total for PLANK AUTO SUPPLY INC.:</b>	<b>1,906.78</b>		POE & ASSOCIATES, INC.	Capital Projects	VO808808	<u>455,671.65</u>	PM-0101: PRGRM MGMT: SP-65: # 51426	TJD4JECH	23A0000227	7/15/2024	455,671.65	Check 23A0000227:	455,671.65		POE & ASSOCIATES, INC.	Capital Projects	VO808997	<u>1,200.00</u>	SP-66: T-26701A: AA-001: APRSL RVW:51367	TJDILL	23A0000233	7/18/2024	1,200.00	Check 23A0000233:	1,200.00		POE & ASSOCIATES, INC.	Capital Projects	VO810049	44,425.00	PM-0101: EWC-28801A: ROW OVRSGT: 51481	TGORE	23A0000250	7/30/2024	50,425.00	VO810094	<u>6,000.00</u>	EWC-28001: AA-003-009: AP RVW: 51480	TGORE	Check 23A0000250:	50,425.00		POE & ASSOCIATES, INC.	General	VO808971	2,987.50	AET-002: MU TP: RES ENG/MILEAGE: 51442	LNELSON	GEN00021489	7/17/2024	76,393.56	VO808963	9,065.00	SP-59: OVRLL PRGM MGMT: INV# 51330	BMANHALT	VO808966	1,655.00	SP-59: GILC EXPRSWY/DATA TRANSF: 51331	BMANHALT	VO808972	46,457.40	AET-004: IND TP: RES ENG/MILE/TST: 51444	TJDILL	VO808973	<u>16,228.66</u>	AET-001: CIM TP: RES ENG/MILE/: 51441	TJDILL	Check GEN00021489:	76,393.56		POE & ASSOCIATES, INC.	General	VO809864	<u>1,350.00</u>	SP-59: OVRLL PRGM MGMT: 51435	BMANHALT	GEN00021528	7/26/2024	1,350.00	Check GEN00021528:	1,350.00		<b>Total for POE &amp; ASSOCIATES, INC.:</b>	<b>585,040.21</b>		PONCA CITY TAG OFFICE - 3617	Revenue Fund	VO808285	<u>152.50</u>	FEE/ISSUANCE 61 PIKEPASS 06/2024	APERINGO	RRV00349573	7/11/2024	152.50	Check RRV00349573:	152.50		<b>Total for PONCA CITY TAG OFFICE - 3617:</b>			<b>152.50</b>						PORTER PUBLIC WORKS AUTHORITY	Revenue Fund	VO807463	49.13	ACCT#692 BULK WATER	BPATTERS	RRV00349162	7/1/2024	111.92	VO807462	<u>62.79</u>	ACCT#508 MUSKOGEE MAINT	BPATTERS	Check RRV00349162:	111.92		<b>Total for PORTER PUBLIC WORKS AUTHORITY:</b>			<b>111.92</b>						POSTAL ANNEX #18024	Revenue Fund	VO808286	<u>17.50</u>	FEE/ISSUANCE 7 PIKEPASS 06/2024	APERINGO	RRV00349574	7/11/2024	17.50	Check RRV00349574:	17.50															
PLANK AUTO SUPPLY INC.	Revenue Fund	VO809564	43.46	SAFETY & MEDICAL SUPPLIES		RDTAYLOR	RRV00350010	7/25/2024		724.47																																																																																																																																																																																																												
		VO809567	55.32	VEHICLE PART AND SUPPLIES		RDTAYLOR																																																																																																																																																																																																																
		VO809573	113.43	VEHICLE PARTS AND SUPPLIES		RDTAYLOR																																																																																																																																																																																																																
		VO809574	419.99	SMALL TOOLS & EQUIP		RDTAYLOR																																																																																																																																																																																																																
		VO809571	-3.14	CREDIT-VEHICLE PARTS AND SUPPLIES		RDTAYLOR																																																																																																																																																																																																																
		VO809575	<u>95.41</u>	VEHICLE PARTS & SUPPLIES		RDTAYLOR																																																																																																																																																																																																																
		Check RRV00350010:	724.47		PLANK AUTO SUPPLY INC.	Revenue Fund			VO810060		<u>59.35</u>	VEHICLE PARTS AND SUPPLIES	RDTAYLOR	RRV00350096	7/31/2024	59.35	Check RRV00350096:	59.35		<b>Total for PLANK AUTO SUPPLY INC.:</b>	<b>1,906.78</b>		POE & ASSOCIATES, INC.	Capital Projects	VO808808	<u>455,671.65</u>	PM-0101: PRGRM MGMT: SP-65: # 51426	TJD4JECH	23A0000227	7/15/2024	455,671.65	Check 23A0000227:	455,671.65		POE & ASSOCIATES, INC.	Capital Projects	VO808997	<u>1,200.00</u>	SP-66: T-26701A: AA-001: APRSL RVW:51367	TJDILL	23A0000233	7/18/2024	1,200.00	Check 23A0000233:	1,200.00		POE & ASSOCIATES, INC.	Capital Projects	VO810049	44,425.00	PM-0101: EWC-28801A: ROW OVRSGT: 51481	TGORE	23A0000250	7/30/2024	50,425.00	VO810094	<u>6,000.00</u>	EWC-28001: AA-003-009: AP RVW: 51480	TGORE	Check 23A0000250:	50,425.00		POE & ASSOCIATES, INC.	General	VO808971	2,987.50	AET-002: MU TP: RES ENG/MILEAGE: 51442	LNELSON	GEN00021489	7/17/2024	76,393.56	VO808963	9,065.00	SP-59: OVRLL PRGM MGMT: INV# 51330	BMANHALT	VO808966	1,655.00	SP-59: GILC EXPRSWY/DATA TRANSF: 51331	BMANHALT	VO808972	46,457.40	AET-004: IND TP: RES ENG/MILE/TST: 51444	TJDILL	VO808973	<u>16,228.66</u>	AET-001: CIM TP: RES ENG/MILE/: 51441	TJDILL	Check GEN00021489:	76,393.56		POE & ASSOCIATES, INC.	General	VO809864	<u>1,350.00</u>	SP-59: OVRLL PRGM MGMT: 51435	BMANHALT	GEN00021528	7/26/2024	1,350.00	Check GEN00021528:	1,350.00		<b>Total for POE &amp; ASSOCIATES, INC.:</b>	<b>585,040.21</b>		PONCA CITY TAG OFFICE - 3617	Revenue Fund	VO808285	<u>152.50</u>	FEE/ISSUANCE 61 PIKEPASS 06/2024	APERINGO	RRV00349573	7/11/2024	152.50	Check RRV00349573:	152.50		<b>Total for PONCA CITY TAG OFFICE - 3617:</b>			<b>152.50</b>						PORTER PUBLIC WORKS AUTHORITY	Revenue Fund	VO807463	49.13	ACCT#692 BULK WATER	BPATTERS	RRV00349162	7/1/2024	111.92	VO807462	<u>62.79</u>	ACCT#508 MUSKOGEE MAINT	BPATTERS	Check RRV00349162:	111.92		<b>Total for PORTER PUBLIC WORKS AUTHORITY:</b>			<b>111.92</b>						POSTAL ANNEX #18024	Revenue Fund	VO808286	<u>17.50</u>	FEE/ISSUANCE 7 PIKEPASS 06/2024	APERINGO	RRV00349574	7/11/2024	17.50	Check RRV00349574:	17.50																																																				
PLANK AUTO SUPPLY INC.	Revenue Fund	VO810060	<u>59.35</u>	VEHICLE PARTS AND SUPPLIES			RDTAYLOR	RRV00350096	7/31/2024	59.35																																																																																																																																																																																																												
		Check RRV00350096:	59.35																																																																																																																																																																																																																			
		<b>Total for PLANK AUTO SUPPLY INC.:</b>	<b>1,906.78</b>																																																																																																																																																																																																																			
POE & ASSOCIATES, INC.	Capital Projects	VO808808	<u>455,671.65</u>	PM-0101: PRGRM MGMT: SP-65: # 51426	TJD4JECH	23A0000227	7/15/2024	455,671.65																																																																																																																																																																																																														
		Check 23A0000227:	455,671.65						POE & ASSOCIATES, INC.	Capital Projects	VO808997	<u>1,200.00</u>	SP-66: T-26701A: AA-001: APRSL RVW:51367	TJDILL	23A0000233	7/18/2024	1,200.00	Check 23A0000233:	1,200.00		POE & ASSOCIATES, INC.	Capital Projects	VO810049	44,425.00	PM-0101: EWC-28801A: ROW OVRSGT: 51481	TGORE	23A0000250	7/30/2024	50,425.00	VO810094	<u>6,000.00</u>	EWC-28001: AA-003-009: AP RVW: 51480	TGORE	Check 23A0000250:	50,425.00		POE & ASSOCIATES, INC.	General	VO808971	2,987.50	AET-002: MU TP: RES ENG/MILEAGE: 51442	LNELSON	GEN00021489	7/17/2024	76,393.56	VO808963	9,065.00	SP-59: OVRLL PRGM MGMT: INV# 51330	BMANHALT	VO808966	1,655.00	SP-59: GILC EXPRSWY/DATA TRANSF: 51331	BMANHALT	VO808972	46,457.40	AET-004: IND TP: RES ENG/MILE/TST: 51444	TJDILL	VO808973	<u>16,228.66</u>	AET-001: CIM TP: RES ENG/MILE/: 51441	TJDILL	Check GEN00021489:	76,393.56		POE & ASSOCIATES, INC.	General	VO809864	<u>1,350.00</u>	SP-59: OVRLL PRGM MGMT: 51435	BMANHALT	GEN00021528	7/26/2024	1,350.00	Check GEN00021528:	1,350.00		<b>Total for POE &amp; ASSOCIATES, INC.:</b>	<b>585,040.21</b>		PONCA CITY TAG OFFICE - 3617	Revenue Fund	VO808285	<u>152.50</u>	FEE/ISSUANCE 61 PIKEPASS 06/2024	APERINGO	RRV00349573	7/11/2024	152.50	Check RRV00349573:	152.50		<b>Total for PONCA CITY TAG OFFICE - 3617:</b>			<b>152.50</b>						PORTER PUBLIC WORKS AUTHORITY	Revenue Fund	VO807463	49.13	ACCT#692 BULK WATER	BPATTERS	RRV00349162	7/1/2024	111.92	VO807462	<u>62.79</u>	ACCT#508 MUSKOGEE MAINT	BPATTERS	Check RRV00349162:	111.92		<b>Total for PORTER PUBLIC WORKS AUTHORITY:</b>			<b>111.92</b>						POSTAL ANNEX #18024	Revenue Fund	VO808286	<u>17.50</u>	FEE/ISSUANCE 7 PIKEPASS 06/2024	APERINGO	RRV00349574	7/11/2024	17.50	Check RRV00349574:	17.50																																																																														
POE & ASSOCIATES, INC.	Capital Projects	VO808997	<u>1,200.00</u>	SP-66: T-26701A: AA-001: APRSL RVW:51367	TJDILL	23A0000233	7/18/2024	1,200.00																																																																																																																																																																																																														
		Check 23A0000233:	1,200.00						POE & ASSOCIATES, INC.	Capital Projects	VO810049	44,425.00	PM-0101: EWC-28801A: ROW OVRSGT: 51481	TGORE	23A0000250	7/30/2024	50,425.00	VO810094	<u>6,000.00</u>	EWC-28001: AA-003-009: AP RVW: 51480			TGORE	Check 23A0000250:	50,425.00					POE & ASSOCIATES, INC.	General	VO808971	2,987.50	AET-002: MU TP: RES ENG/MILEAGE: 51442	LNELSON	GEN00021489			7/17/2024	76,393.56	VO808963	9,065.00				SP-59: OVRLL PRGM MGMT: INV# 51330	BMANHALT	VO808966	1,655.00	SP-59: GILC EXPRSWY/DATA TRANSF: 51331	BMANHALT	VO808972	46,457.40	AET-004: IND TP: RES ENG/MILE/TST: 51444	TJDILL	VO808973	<u>16,228.66</u>	AET-001: CIM TP: RES ENG/MILE/: 51441	TJDILL	Check GEN00021489:	76,393.56		POE & ASSOCIATES, INC.	General			VO809864	<u>1,350.00</u>	SP-59: OVRLL PRGM MGMT: 51435					BMANHALT	GEN00021528	7/26/2024	1,350.00	Check GEN00021528:	1,350.00		<b>Total for POE &amp; ASSOCIATES, INC.:</b>	<b>585,040.21</b>		PONCA CITY TAG OFFICE - 3617	Revenue Fund	VO808285	<u>152.50</u>	FEE/ISSUANCE 61 PIKEPASS 06/2024	APERINGO	RRV00349573	7/11/2024	152.50	Check RRV00349573:	152.50		<b>Total for PONCA CITY TAG OFFICE - 3617:</b>			<b>152.50</b>											PORTER PUBLIC WORKS AUTHORITY	Revenue Fund	VO807463	49.13	ACCT#692 BULK WATER	BPATTERS	RRV00349162	7/1/2024	111.92	VO807462	<u>62.79</u>	ACCT#508 MUSKOGEE MAINT	BPATTERS	Check RRV00349162:	111.92		<b>Total for PORTER PUBLIC WORKS AUTHORITY:</b>			<b>111.92</b>						POSTAL ANNEX #18024	Revenue Fund	VO808286	<u>17.50</u>	FEE/ISSUANCE 7 PIKEPASS 06/2024	APERINGO	RRV00349574	7/11/2024	17.50	Check RRV00349574:	17.50																																																																					
POE & ASSOCIATES, INC.	Capital Projects	VO810049	44,425.00	PM-0101: EWC-28801A: ROW OVRSGT: 51481	TGORE	23A0000250	7/30/2024	50,425.00																																																																																																																																																																																																														
		VO810094	<u>6,000.00</u>	EWC-28001: AA-003-009: AP RVW: 51480	TGORE																																																																																																																																																																																																																	
		Check 23A0000250:	50,425.00		POE & ASSOCIATES, INC.				General	VO808971	2,987.50	AET-002: MU TP: RES ENG/MILEAGE: 51442	LNELSON	GEN00021489	7/17/2024	76,393.56	VO808963	9,065.00	SP-59: OVRLL PRGM MGMT: INV# 51330	BMANHALT	VO808966	1,655.00	SP-59: GILC EXPRSWY/DATA TRANSF: 51331	BMANHALT	VO808972	46,457.40	AET-004: IND TP: RES ENG/MILE/TST: 51444	TJDILL	VO808973			<u>16,228.66</u>	AET-001: CIM TP: RES ENG/MILE/: 51441	TJDILL	Check GEN00021489:		76,393.56				POE & ASSOCIATES, INC.	General	VO809864	<u>1,350.00</u>	SP-59: OVRLL PRGM MGMT: 51435	BMANHALT	GEN00021528	7/26/2024	1,350.00	Check GEN00021528:	1,350.00		<b>Total for POE &amp; ASSOCIATES, INC.:</b>	<b>585,040.21</b>		PONCA CITY TAG OFFICE - 3617	Revenue Fund	VO808285	<u>152.50</u>	FEE/ISSUANCE 61 PIKEPASS 06/2024	APERINGO	RRV00349573	7/11/2024	152.50	Check RRV00349573:	152.50		<b>Total for PONCA CITY TAG OFFICE - 3617:</b>			<b>152.50</b>						PORTER PUBLIC WORKS AUTHORITY	Revenue Fund	VO807463	49.13	ACCT#692 BULK WATER	BPATTERS	RRV00349162	7/1/2024	111.92	VO807462	<u>62.79</u>	ACCT#508 MUSKOGEE MAINT	BPATTERS	Check RRV00349162:	111.92		<b>Total for PORTER PUBLIC WORKS AUTHORITY:</b>			<b>111.92</b>						POSTAL ANNEX #18024	Revenue Fund	VO808286	<u>17.50</u>	FEE/ISSUANCE 7 PIKEPASS 06/2024	APERINGO	RRV00349574	7/11/2024	17.50	Check RRV00349574:	17.50																																																																																																						
POE & ASSOCIATES, INC.	General	VO808971	2,987.50	AET-002: MU TP: RES ENG/MILEAGE: 51442		LNELSON	GEN00021489	7/17/2024		76,393.56																																																																																																																																																																																																												
		VO808963	9,065.00	SP-59: OVRLL PRGM MGMT: INV# 51330		BMANHALT																																																																																																																																																																																																																
		VO808966	1,655.00	SP-59: GILC EXPRSWY/DATA TRANSF: 51331		BMANHALT																																																																																																																																																																																																																
		VO808972	46,457.40	AET-004: IND TP: RES ENG/MILE/TST: 51444		TJDILL																																																																																																																																																																																																																
		VO808973	<u>16,228.66</u>	AET-001: CIM TP: RES ENG/MILE/: 51441	TJDILL																																																																																																																																																																																																																	
Check GEN00021489:	76,393.56		POE & ASSOCIATES, INC.	General	VO809864	<u>1,350.00</u>	SP-59: OVRLL PRGM MGMT: 51435	BMANHALT	GEN00021528	7/26/2024	1,350.00	Check GEN00021528:	1,350.00		<b>Total for POE &amp; ASSOCIATES, INC.:</b>	<b>585,040.21</b>		PONCA CITY TAG OFFICE - 3617	Revenue Fund	VO808285	<u>152.50</u>	FEE/ISSUANCE 61 PIKEPASS 06/2024	APERINGO	RRV00349573	7/11/2024	152.50	Check RRV00349573:	152.50		<b>Total for PONCA CITY TAG OFFICE - 3617:</b>			<b>152.50</b>						PORTER PUBLIC WORKS AUTHORITY	Revenue Fund	VO807463	49.13	ACCT#692 BULK WATER	BPATTERS	RRV00349162	7/1/2024	111.92	VO807462	<u>62.79</u>	ACCT#508 MUSKOGEE MAINT	BPATTERS	Check RRV00349162:	111.92		<b>Total for PORTER PUBLIC WORKS AUTHORITY:</b>			<b>111.92</b>						POSTAL ANNEX #18024	Revenue Fund	VO808286	<u>17.50</u>	FEE/ISSUANCE 7 PIKEPASS 06/2024	APERINGO	RRV00349574	7/11/2024	17.50	Check RRV00349574:	17.50																																																																																																																																												
POE & ASSOCIATES, INC.	General	VO809864			<u>1,350.00</u>	SP-59: OVRLL PRGM MGMT: 51435	BMANHALT					GEN00021528	7/26/2024	1,350.00																																																																																																																																																																																																								
		Check GEN00021528:			1,350.00																																																																																																																																																																																																																	
		<b>Total for POE &amp; ASSOCIATES, INC.:</b>	<b>585,040.21</b>																																																																																																																																																																																																																			
PONCA CITY TAG OFFICE - 3617	Revenue Fund	VO808285	<u>152.50</u>	FEE/ISSUANCE 61 PIKEPASS 06/2024	APERINGO	RRV00349573	7/11/2024	152.50																																																																																																																																																																																																														
		Check RRV00349573:	152.50																																																																																																																																																																																																																			
<b>Total for PONCA CITY TAG OFFICE - 3617:</b>			<b>152.50</b>																																																																																																																																																																																																																			
PORTER PUBLIC WORKS AUTHORITY	Revenue Fund	VO807463	49.13	ACCT#692 BULK WATER	BPATTERS	RRV00349162	7/1/2024	111.92																																																																																																																																																																																																														
		VO807462	<u>62.79</u>	ACCT#508 MUSKOGEE MAINT	BPATTERS																																																																																																																																																																																																																	
		Check RRV00349162:	111.92																																																																																																																																																																																																																			
<b>Total for PORTER PUBLIC WORKS AUTHORITY:</b>			<b>111.92</b>																																																																																																																																																																																																																			
POSTAL ANNEX #18024	Revenue Fund	VO808286	<u>17.50</u>	FEE/ISSUANCE 7 PIKEPASS 06/2024	APERINGO	RRV00349574	7/11/2024	17.50																																																																																																																																																																																																														
		Check RRV00349574:	17.50																																																																																																																																																																																																																			

Vendor Name	Fund Desc	Voucher NO.	Amt Applied	Description	Approver	Check No.	Date Paid	Amt Check
		<b>Total for POSTAL ANNEX #18024:</b>	<b>17.50</b>					
POSTAL ANNEX #20003	Revenue Fund	VO808287	17.50	FEE/ISSUANCE 7 PIKEPASS 06/2024	APERINGO	RRV00349575	7/11/2024	17.50
		Check RRV00349575:	17.50					
		<b>Total for POSTAL ANNEX #20003:</b>	<b>17.50</b>					
POTEAU TAG AGENCY	Revenue Fund	VO808288	95.00	FEE/ISSUANCE 38 PIKEPASS 06/2024	APERINGO	RRV00349576	7/11/2024	95.00
		Check RRV00349576:	95.00					
		<b>Total for POTEAU TAG AGENCY:</b>	<b>95.00</b>					
POWELL, RHONDA	Revenue Fund	VO808835	31.07	JULY 2024 EXPENSES	TGORE	RRV00349747	7/16/2024	31.07
		Check RRV00349747:	31.07					
		<b>Total for POWELL, RHONDA:</b>	<b>31.07</b>					
PRAGUE TAG AGENCY	Revenue Fund	VO809860	37.50	FEE/ISSUANCE 15 PIKEPASS 6/2024	APERINGO	RRV00350041	7/26/2024	37.50
		Check RRV00350041:	37.50					
		<b>Total for PRAGUE TAG AGENCY:</b>	<b>37.50</b>					
PRATTVILLE TAG AGENCY	Revenue Fund	VO808290	120.00	FEE/ISSUANCE 48 PIKEPASS 06/2024	APERINGO	RRV00349577	7/11/2024	120.00
		Check RRV00349577:	120.00					
		<b>Total for PRATTVILLE TAG AGENCY:</b>	<b>120.00</b>					
PRECISION FLUID POWER, INC.	Revenue Fund	VO807613	591.00	EQUIPMENT REPAIR	RDTAYLOR	RRV00349384	7/9/2024	591.00
		Check RRV00349384:	591.00					
		<b>Total for PRECISION FLUID POWER, INC.:</b>	<b>591.00</b>					
PREGLER LAWN & GARDEN	Revenue Fund	VO809103	379.82	EQUIPMENT PARTS AND SUPPLIES	BELLIS	RRV00349867	7/18/2024	734.51
		VO809105	354.69	EQUIPMENT PARTS AND SUPPLIES	BELLIS			
		Check RRV00349867:	734.51					
		<b>Total for PREGLER LAWN &amp; GARDEN:</b>	<b>734.51</b>					
PREHIRE SCREENING SERVICES LLC	Revenue Fund	VO808120	323.50	OTHER PROFESSIONAL SERVICES	BJEPSEN	RRV00349412	7/9/2024	323.50
		Check RRV00349412:	323.50					
		<b>Total for PREHIRE SCREENING SERVICES LLC:</b>	<b>323.50</b>					
PREMIER TRUCK GROUP	General	VO809249	141,625.00	2025 FREIGHTLINER:# 120DE-VU5327: WR	DMA4TGAT	GEN00021506	7/22/2024	141,625.00
		Check GEN00021506:	141,625.00					
PREMIER TRUCK GROUP	Revenue Fund	VO809109	469.40	EQUIPMENT REPAIR	JJENKINS	RRV00349869	7/18/2024	2,594.45
		VO809110	1,005.19	VEHICLE PARTS AND SUPPLIES	SALLEN			
		VO809106	440.98	EQUIPMENT PARTS AND SUPPLIES	BELLIS			
		VO809108	497.60	EQUIPMENT PARTS AND SUPPLIES	BELLIS			
		VO809112	181.28	VEHICLE PARTS AND SUPPLIES	RROWEN			
		Check RRV00349869:	2,594.45					
PREMIER TRUCK GROUP	Revenue Fund	VO809568	605.24	VEHICLE PARTS AND SUPPLIES	RDTAYLOR	RRV00349997	7/25/2024	605.24
		Check RRV00349997:	605.24					
PREMIER TRUCK GROUP	Revenue Fund	VO810062	97.27	VEHICLE PARTS AND SUPPLIES	DCRAIG	RRV00350097	7/31/2024	97.27
		Check RRV00350097:	97.27					
		<b>Total for PREMIER TRUCK GROUP:</b>	<b>144,921.96</b>					
PREMIERE PRESS & GRAPHICS	Revenue Fund	VO808121	1,547.30	TOLL BOOTH SUPPLIES-DEPOSIT SLIPS	JMELTON	RRV00349413	7/9/2024	1,547.30
		Check RRV00349413:	1,547.30					

Vendor Name	Fund Desc	Voucher NO.	Amt Applied	Description	Approver	Check No.	Date Paid	Amt Check
<b>Total for PREMIERE PRESS &amp; GRAPHICS:</b>			<b>1,547.30</b>					
PRESORT FIRST CLASS, INC.	Revenue Fund	VO809114	271.11	POSTAGE	AHEITZ	RRV00349868	7/18/2024	704.98
		VO809116	433.87	POSTAGE	APERINGO			
		Check RRV00349868:	704.98					
<b>Total for PRESORT FIRST CLASS, INC.:</b>			<b>704.98</b>					
PRO OVERHEAD DOOR	Revenue Fund	VO809578	913.00	EQUIP PARTS; BUILD MAINT SERV	JJENKINS	RRV00349998	7/25/2024	913.00
		Check RRV00349998:	913.00					
<b>Total for PRO OVERHEAD DOOR:</b>			<b>913.00</b>					
PROTIVITI GOVERNMENT SERVICES, General		VO808425	11,078.64	OTHER PROFESSIONAL SVCS ; INV-32689	DMA4TGAT	GEN00021470	7/11/2024	22,454.64
		VO808426	11,376.00	OTHER PROFESSIONAL SVCS ; INV-32782	DMA4TGAT			
		Check GEN00021470:	22,454.64					
<b>Total for PROTIVITI GOVERNMENT SERVICES, INC:</b>			<b>22,454.64</b>					
PRUETTS FOOD, INC.	Revenue Fund	VO809118	404.77	TRAINING & EDUCATION	BELLIS	RRV00349870	7/18/2024	404.77
		Check RRV00349870:	404.77					
<b>Total for PRUETTS FOOD, INC.:</b>			<b>404.77</b>					
PRYOR TAG AGENCY #4922 - LINDSAY	Revenue Fund	VO808291	197.50	FEE/ISSUANCE 79 PIKEPASS 06/2024	APERINGO	RRV00349579	7/11/2024	197.50
		Check RRV00349579:	197.50					
<b>Total for PRYOR TAG AGENCY #4922 - LINDSAY HOOVER:</b>			<b>197.50</b>					
PRYOR WASTE & RECYCLING L.L.C.	Revenue Fund	VO809581	400.00	SOLID WASTE DISPOSAL	CHUGHES	RRV00349999	7/25/2024	400.00
		Check RRV00349999:	400.00					
<b>Total for PRYOR WASTE &amp; RECYCLING L.L.C.:</b>			<b>400.00</b>					
PURCELL TAG AGENCY - MARIA HART	Revenue Fund	VO808292	50.00	FEE/ISSUANCE 20 PIKEPASS 06/2024	APERINGO	RRV00349580	7/11/2024	50.00
		Check RRV00349580:	50.00					
<b>Total for PURCELL TAG AGENCY - MARIA HART #4414:</b>			<b>50.00</b>					
QUAIL TAG AGENCY	Revenue Fund	VO808293	365.00	FEE/ISSUANCE 146 PIKEPASS 06/2024	APERINGO	RRV00349581	7/11/2024	365.00
		Check RRV00349581:	365.00					
<b>Total for QUAIL TAG AGENCY:</b>			<b>365.00</b>					
QUALITY FIRE & SAFETY	Revenue Fund	VO807614	2,016.50	OTHER MAINTENANCE	SALLEN	RRV00349385	7/9/2024	3,389.50
		VO807615	1,373.00	OTHER MAINTENANCE	SALLEN			
		Check RRV00349385:	3,389.50					
<b>Total for QUALITY FIRE &amp; SAFETY:</b>			<b>3,389.50</b>					
QUANTIE AUTO SUPPLY	Revenue Fund	VO808915	125.94	BUILDING MAINTENANCE SUPPLIES - EQUIPMEN	CHUGHES	RRV00349907	7/23/2024	125.94
		Check RRV00349907:	125.94					
QUANTIE AUTO SUPPLY	Revenue Fund	VO809583	69.06	EQUIPMENT PARTS AND SUPPLIES	CHUGHES	RRV00350000	7/25/2024	180.02
		VO809582	110.96	EQUIPMENT PARTS AND SUPPLIES	CHUGHES			
		Check RRV00350000:	180.02					
QUANTIE AUTO SUPPLY	Revenue Fund	VO810064	426.99	VEHICLE PARTS; EQUIPMENT PARTS	CHUGHES	RRV00350098	7/31/2024	426.99
		Check RRV00350098:	426.99					
<b>Total for QUANTIE AUTO SUPPLY:</b>			<b>732.95</b>					
QUESTMARK INFORMATION MANAGE	Revenue Fund	VO809041	18,532.45	POSTAGE/PRINT,PPS MAY 2024 ; 1010541	DMA4TGAT	REV00016053	7/18/2024	173,240.27
		VO809040	99,707.82	PRINTING, PP MAY 2024 ; 1010397	DMA4TGAT			



Vendor Name	Fund Desc	Voucher NO.	Amt Applied	Description	Approver	Check No.	Date Paid	Amt Check
		VO809042	55,000.00	POSTAGE, JULY 2024 ; 1010543	DMA4TGAT			
		Check REV00016053:	173,240.27					
QUESTMARK INFORMATION MANA	Revenue Fund	VO809252	700,000.00	POSTAGE PP, JULY 2024; 1010542	DMA4TGAT	REV00016058	7/19/2024	700,000.00
		Check REV00016058:	700,000.00					
QUESTMARK INFORMATION MANA	Revenue Fund	VO808123	3,004.83	PRINTING	JPORTER	RRV00349414	7/9/2024	3,004.83
		Check RRV00349414:	3,004.83					
<b>Total for QUESTMARK INFORMATION MANAGEMENT, INC.:</b>			<b>876,245.10</b>					
QUIKSERVICE STEEL COMPANY	Revenue Fund	VO808918	34.55	VEHICLE PARTS	JJENKINS	RRV00349787	7/17/2024	34.55
		Check RRV00349787:	34.55					
<b>Total for QUIKSERVICE STEEL COMPANY:</b>			<b>34.55</b>					
QUILL LLC	Revenue Fund	VO807745	14.28	OFFICE SUPPLIES	BWESTER	RRV00349295	7/5/2024	31.73
		VO807743	17.45	OFFICE SUPPLIES	BWESTER			
		Check RRV00349295:	31.73					
QUILL LLC	Revenue Fund	VO809124	53.98	OTHER COMMODITIES AND SUPPLIES	BELLIS	RRV00349871	7/18/2024	53.98
		Check RRV00349871:	53.98					
<b>Total for QUILL LLC:</b>			<b>85.71</b>					
RALPH & SONS	Revenue Fund	VO807746	42.90	EQUIPMENT REPAIRS	KWALLIS	RRV00349296	7/5/2024	42.90
		Check RRV00349296:	42.90					
RALPH & SONS	Revenue Fund	VO807990	34.00	EQUIPMENT REPAIRS	KWALLIS	RRV00349374	7/8/2024	72.50
		VO807993	38.50	EQUIPMENT REPAIR	KWALLIS			
		Check RRV00349374:	72.50					
RALPH & SONS	Revenue Fund	VO808315	24.00	EQUIPMENT REPAIR	KWALLIS	RRV00349618	7/11/2024	24.00
		Check RRV00349618:	24.00					
RALPH & SONS	Revenue Fund	VO809120	20.00	EQUIPMENT REPAIR	KWALLIS	RRV00349872	7/18/2024	20.00
		Check RRV00349872:	20.00					
RALPH & SONS	Revenue Fund	VO809340	20.00	EQUIPMENT REPAIR	KWALLIS	RRV00349909	7/23/2024	20.00
		Check RRV00349909:	20.00					
RALPH & SONS	Revenue Fund	VO809589	20.00	EQUIPMENT REPAIR	KWALLIS	RRV00350002	7/25/2024	89.50
		VO809584	20.00	EQUIPMENT REPAIR	KWALLIS			
		VO809587	49.50	EQUIPMENT REPAIR	KWALLIS			
		Check RRV00350002:	89.50					
RALPH & SONS	Revenue Fund	VO810070	20.00	EQUIPMENT REPAIR	KWALLIS	RRV00350100	7/31/2024	62.50
		VO810068	18.50	EQUIPMENT REPAIR	KWALLIS			
		VO810067	24.00	EQUIPMENT REPAIR	KWALLIS			
		Check RRV00350100:	62.50					
<b>Total for RALPH &amp; SONS:</b>			<b>331.40</b>					
RALPH'S PACKING CO	Revenue Fund	VO808319	79.26	EMPLOYEE INCENTIVE AWARDS-FOOD	RROWEN	RRV00349617	7/11/2024	79.26
		Check RRV00349617:	79.26					
<b>Total for RALPH'S PACKING CO:</b>			<b>79.26</b>					
RAYS WESTSIDE TAG AGENCY	Revenue Fund	VO808294	230.00	FEE/ISSUANCE 92 PIKEPASS 06/2024	APERINGO	RRV00349582	7/11/2024	230.00

Vendor Name	Fund Desc	Voucher NO.	Amt Applied	Description	Approver	Check No.	Date Paid	Amt Check
		Check RRV00349582:	230.00					
		<b>Total for RAYS WESTSIDE TAG AGENCY:</b>	<b>230.00</b>					
REASOR'S	Revenue Fund	VO809590	41.34	TRAINING & EDUCATION	JJENKINS	RRV00350001	7/25/2024	41.34
		Check RRV00350001:	41.34					
		<b>Total for REASOR'S:</b>	<b>41.34</b>					
RED CAP TAG AGENCY	Revenue Fund	VO808297	70.00	FEE/ISSUANCE 28 PIKEPASS 06/2024	APERINGO	RRV00349584	7/11/2024	70.00
		Check RRV00349584:	70.00					
		<b>Total for RED CAP TAG AGENCY:</b>	<b>70.00</b>					
RED RIVER FORD LINCOLN, INC.	Revenue Fund	VO808308	15.00	FEE/INVOICE 6 PIKEPASS 06/2024	APERINGO	RRV00349585	7/11/2024	15.00
		Check RRV00349585:	15.00					
		<b>Total for RED RIVER FORD LINCOLN, INC.:</b>	<b>15.00</b>					
REPUBLIC SERVICES #060	Revenue Fund	VO808904	890.57	SOLID WASTE	PGOGGIN	RRV00349782	7/17/2024	890.57
		Check RRV00349782:	890.57					
REPUBLIC SERVICES #060	Revenue Fund	VO809125	726.90	SOLID WASTE DISPOSAL	JSMART	RRV00349854	7/18/2024	1,813.04
		VO809126	1,086.14	SOLID WASTE DISPOSAL	SALLEN			
		Check RRV00349854:	1,813.04					
		<b>Total for REPUBLIC SERVICES #060:</b>	<b>2,703.61</b>					
REPUBLIC SERVICES - #375	Revenue Fund	VO808919	824.51	SOLID WASTE	BWESTER	RRV00349788	7/17/2024	824.51
		Check RRV00349788:	824.51					
REPUBLIC SERVICES - #375	Revenue Fund	VO810072	762.77	SOLID WASTE DISPOSAL; LATE FEES	BWESTER	RRV00350099	7/31/2024	762.77
		Check RRV00350099:	762.77					
		<b>Total for REPUBLIC SERVICES - #375:</b>	<b>1,587.28</b>					
RIGGS TAG AGENCY	Revenue Fund	VO808309	40.00	FEE/ISSUANCE 16 PIKEPASS 06/2024	APERINGO	RRV00349586	7/11/2024	40.00
		Check RRV00349586:	40.00					
		<b>Total for RIGGS TAG AGENCY:</b>	<b>40.00</b>					
RIPPY, JASON	Revenue Fund	VO808832	117.52	JULY 2024 EXPENSES	BELLIS	RRV00349743	7/16/2024	117.52
		Check RRV00349743:	117.52					
		<b>Total for RIPPY, JASON:</b>	<b>117.52</b>					
ROBERTSON TIRE	Revenue Fund	VO808322	331.80	VEHICLE PARTS; EQUIPMENT REPAIR	JJENKINS	RRV00349619	7/11/2024	446.70
		VO808326	114.90	VEHICLE PARTS; EQUIPMENT REPAIR	JJENKINS			
		Check RRV00349619:	446.70					
ROBERTSON TIRE	Revenue Fund	VO809593	200.40	VEHICLE PARTS; EQUIPMENT REPAIR	JJENKINS	RRV00350003	7/25/2024	200.40
		Check RRV00350003:	200.40					
		<b>Total for ROBERTSON TIRE:</b>	<b>647.10</b>					
ROBINSON AGENCY	Revenue Fund	VO808311	5.00	FEE/ISSUANCE 2 PIKEPASS 06/2024	APERINGO	RRV00349587	7/11/2024	5.00
		Check RRV00349587:	5.00					
		<b>Total for ROBINSON AGENCY:</b>	<b>5.00</b>					
ROBINSON CONSTRUCTION, INC.	General	VO807641	738,341.27	SP-63B; ESTIMATE NO. 2	TJD4JECH	GEN00021441	7/3/2024	738,341.27
		Check GEN00021441:	738,341.27					
ROBINSON CONSTRUCTION, INC.	General	VO809013	733,003.69	SP-63B; ESTIMATE NO. 3	TJD4JECH	GEN00021493	7/17/2024	733,003.69

Vendor Name	Fund Desc	Voucher NO.	Amt Applied	Description	Approver	Check No.	Date Paid	Amt Check
		Check GEN00021493:	733,003.69					
ROBINSON CONSTRUCTION, INC.	General	VO809526	1,703,023.19	IN-MC-62G: ESTIMATE NO. 7	TJD4JECH	GEN00021514	7/25/2024	1,703,023.19
		Check GEN00021514:	1,703,023.19					
ROBINSON CONSTRUCTION, INC.	General	VO809534	416,532.85	SP-63A: ESTIMATE NO. 10	TJD4JECH	GEN00021515	7/25/2024	416,532.85
		Check GEN00021515:	416,532.85					
<b>Total for ROBINSON CONSTRUCTION, INC.:</b>			<b>3,590,901.00</b>					
ROBINSON GLASS INC.	Revenue Fund	VO808312	52.50	FEE/ISSUANCE 21 PIKEPASS 06/2024	APERINGO	RRV00349589	7/11/2024	52.50
		Check RRV00349589:	52.50					
<b>Total for ROBINSON GLASS INC.:</b>			<b>52.50</b>					
ROBINSON GLASS OF TULSA, INC.	Revenue Fund	VO808313	125.00	FEE/ISSUANCE 50 PIKEPASS 06/2024	APERINGO	RRV00349588	7/11/2024	125.00
		Check RRV00349588:	125.00					
<b>Total for ROBINSON GLASS OF TULSA, INC.:</b>			<b>125.00</b>					
ROD PUMPS, INC.	Revenue Fund	VO809127	12.00	HARDWARE	RDTAYLOR	RRV00349873	7/18/2024	12.00
		Check RRV00349873:	12.00					
<b>Total for ROD PUMPS, INC.:</b>			<b>12.00</b>					
RON'S HEAT & AIR LLC.	Revenue Fund	VO809128	382.00	BUILD MAINT SUPP; BUILD MAINT SERV	DCRAIG	RRV00349874	7/18/2024	382.00
		Check RRV00349874:	382.00					
<b>Total for RON'S HEAT &amp; AIR LLC.:</b>			<b>382.00</b>					
RON-CO PLUMBING	Revenue Fund	VO810073	4,200.00	OTHER CONTRACTUAL SERVICES	MCOLLINS	RRV00350101	7/31/2024	4,200.00
		Check RRV00350101:	4,200.00					
<b>Total for RON-CO PLUMBING:</b>			<b>4,200.00</b>					
ROSS SEED COMPANY	Revenue Fund	VO807994	47.98	INSECTICIDES-BUILDING MAINTENANCE	KWALLIS	RRV00349375	7/8/2024	47.98
		Check RRV00349375:	47.98					
ROSS SEED COMPANY	Revenue Fund	VO808334	199.98	INSECTICIDES & HERBICIDES	KWALLIS	RRV00349620	7/11/2024	199.98
		Check RRV00349620:	199.98					
ROSS SEED COMPANY	Revenue Fund	VO809129	49.98	INSECTICIDES AND HERBICIDES	KWALLIS	RRV00349875	7/18/2024	49.98
		Check RRV00349875:	49.98					
ROSS SEED COMPANY	Revenue Fund	VO809596	199.98	INSECTICIDES & HERBICIDES	KWALLIS	RRV00350004	7/25/2024	199.98
		Check RRV00350004:	199.98					
<b>Total for ROSS SEED COMPANY:</b>			<b>497.92</b>					
ROWEN, RAYMOND	Revenue Fund	VO808131	118.72	JULY 2024 EXPENSES	SALLEN	RRV00349457	7/9/2024	118.72
		Check RRV00349457:	118.72					
<b>Total for ROWEN, RAYMOND:</b>			<b>118.72</b>					
RUNYAN WRECKER SERVICE	Revenue Fund	VO809598	20.00	EQUIPMENT REPAIR	CSTEVENS	RRV00350005	7/25/2024	20.00
		Check RRV00350005:	20.00					
<b>Total for RUNYAN WRECKER SERVICE:</b>			<b>20.00</b>					
RURAL WATER DISTRICT # 1 - MURR.	Revenue Fund	VO808009	60.51	WATER DISTRICT	BPATTERS	EFT018777	7/9/2024	60.51
		Check EFT018777:	60.51					
<b>Total for RURAL WATER DISTRICT # 1 - MURRAY COUNTY:</b>			<b>60.51</b>					

Vendor Name	Fund Desc	Voucher NO.	Amt Applied	Description	Approver	Check No.	Date Paid	Amt Check
RURAL WATER DISTRICT # 5 - ADAIR	Revenue Fund	VO807443	25.00	WATER	BPATTERS	EFT018733	7/1/2024	25.00
		Check EFT018733:	25.00					
<b>Total for RURAL WATER DISTRICT # 5 - ADAIR:</b>			<b>25.00</b>					
RURAL WATER DISTRICT # 5 - CLAREI	Revenue Fund	VO807439	28.00	WATER	BPATTERS	EFT018734	7/1/2024	28.00
		Check EFT018734:	28.00					
<b>Total for RURAL WATER DISTRICT # 5 - CLAREMORE:</b>			<b>28.00</b>					
RURAL WATER DISTRICT # 5 - MUSKOGEE	Revenue Fund	VO807658	76.69	ACCT#899 MUSKOGEE MAINT	BPATTERS	RRV00349244	7/3/2024	76.69
		Check RRV00349244:	76.69					
<b>Total for RURAL WATER DISTRICT # 5 - MUSKOGEE:</b>			<b>76.69</b>					
RURAL WATER DISTRICT # 5 - PITTSBURG CO.	Revenue Fund	VO808010	1,345.19	WATER SERVICE	BPATTERS	EFT018778	7/9/2024	1,345.19
		Check EFT018778:	1,345.19					
<b>Total for RURAL WATER DISTRICT # 5 - PITTSBURG CO.:</b>			<b>1,345.19</b>					
RURAL WATER DISTRICT # 6 - GRADY COUNTY	Revenue Fund	VO807473	1,233.31	WATER SERVICE	BPATTERS	EFT018737	7/1/2024	1,233.31
		Check EFT018737:	1,233.31					
<b>Total for RURAL WATER DISTRICT # 6 - GRADY COUNTY:</b>			<b>1,233.31</b>					
RURAL WATER DISTRICT #2 - OTTAWA COUNTY	Revenue Fund	VO807657	24.00	ACCT#1044600 AFTON TOLL GATE	BPATTERS	RRV00349243	7/3/2024	24.00
		Check RRV00349243:	24.00					
<b>Total for RURAL WATER DISTRICT #2 - OTTAWA COUNTY:</b>			<b>24.00</b>					
RURAL WATER DISTRICT #5 - WAGONER COUNTY	Revenue Fund	VO807729	30.00	WATER	BPATTERS	EFT018768	7/5/2024	30.00
		Check EFT018768:	30.00					
<b>Total for RURAL WATER DISTRICT #5 - WAGONER COUNTY:</b>			<b>30.00</b>					
RURAL WATER DISTRICT-WAGONER CTY #4	Revenue Fund	VO807722	16.50	WATER SERVICE	BPATTERS	EFT018769	7/5/2024	16.50
		Check EFT018769:	16.50					
<b>Total for RURAL WATER DISTRICT-WAGONER CTY #4:</b>			<b>16.50</b>					
RURAL WATER MANAGEMENT DISTRICT # 3	Revenue Fund	VO807904	52.00	ACCT#6760 FFETCHER MAINT	BPATTERS	RRV00349334	7/8/2024	52.00
		Check RRV00349334:	52.00					
<b>Total for RURAL WATER MANAGEMENT DISTRICT # 3:</b>			<b>52.00</b>					
RURAL WATER- CREEK CTY#3 - SAPULPA	Revenue Fund	VO807595	61.50	WATER SERVICE	BPATTERS	EFT018751	7/2/2024	61.50
		Check EFT018751:	61.50					
<b>Total for RURAL WATER- CREEK CTY#3 - SAPULPA:</b>			<b>61.50</b>					
RUTH SHYER	General	VO809413	3,250.00	OTHER PROFESSIONAL SVCS ; 592	DMA4TGAT	GEN00021511	7/24/2024	3,250.00
		Check GEN00021511:	3,250.00					
<b>Total for RUTH SHYER:</b>			<b>3,250.00</b>					
RYAN WHALEY ATTORNEYS	General	VO807937	35,879.76	MAY 24' LGL FEE: GEN RSRCH/ INVST: 50217	JPORTER	GEN00021450	7/8/2024	35,879.76
		Check GEN00021450:	35,879.76					
<b>Total for RYAN WHALEY ATTORNEYS:</b>			<b>35,879.76</b>					
S & W LLC	Revenue Fund	VO807441	429.60	SMALL TOOLS & SUPPLIES	RDTAYLOR	RRV00349190	7/2/2024	429.60
		Check RRV00349190:	429.60					
<b>Total for S &amp; W LLC:</b>			<b>429.60</b>					
SAF-T-GLOVE, INC.	Revenue Fund	VO809366	98.25	SAFETY&MEDICAL; SHIPPING	RDTAYLOR	RRV00349918	7/24/2024	98.25
		Check RRV00349918:	98.25					

Vendor Name	Fund Desc	Voucher NO.	Amt Applied	Description	Approver	Check No.	Date Paid	Amt Check
		<b>Total for SAF-T-GLOVE, INC.:</b>	<u>98.25</u>					
SAFELITE AUTOGLASS	Revenue Fund	VO809360	478.58	EQUIPMENT REPAIR	PGOGGIN	RRV00349917	7/23/2024	478.58
		Check RRV00349917:	<u>478.58</u>					
		<b>Total for SAFELITE AUTOGLASS:</b>	<u>478.58</u>					
SALINA - SPAVINAW TELEPHONE CO	Revenue Fund	VO808016	139.86	PHONE	JLYTLE	EFT018781	7/9/2024	139.86
		Check EFT018781:	<u>139.86</u>					
		<b>Total for SALINA - SPAVINAW TELEPHONE CO.:</b>	<u>139.86</u>					
SALLISAW TAG AGENCY	Revenue Fund	VO808314	157.50	FEE/ISSUANCE 63 PIKEPASS 06/2024	APERINGO	RRV00349590	7/11/2024	157.50
		Check RRV00349590:	<u>157.50</u>					
		<b>Total for SALLISAW TAG AGENCY:</b>	<u>157.50</u>					
SAM'S CLUB/GEGRB	Revenue Fund	VO809130	639.26	EMPLOYEE INCENTIVE-FOOD; OTHER COMM	PWILLIAM	RRV00349876	7/18/2024	1,489.53
		VO809132	39.99	FINANCIAL CHARGES-LATE FEES	PWILLIAM			
		VO809131	748.98	OFFICE FURNITURE	PWILLIAM			
		VO809133	61.30	FINANCIAL CHARGES-INTEREST CHARGE	PWILLIAM			
		Check RRV00349876:	<u>1,489.53</u>					
SAM'S CLUB/GEGRB	Revenue Fund	VO809362	39.93	FINANCIAL CHARGES-INTEREST FEES	PWILLIAM	RRV00349916	7/23/2024	198.93
		VO809361	159.00	OFFICE FURNITURE	PWILLIAM			
		Check RRV00349916:	<u>198.93</u>					
		<b>Total for SAM'S CLUB/GEGRB:</b>	<u>1,688.46</u>					
SAMS TIRE & WHEEL LLC - VINITA	Revenue Fund	VO808690	14.00	EQUIPMENT REPAIRS	DCRAIG	RRV00349789	7/17/2024	14.00
		Check RRV00349789:	<u>14.00</u>					
		<b>Total for SAMS TIRE &amp; WHEEL LLC - VINITA:</b>	<u>14.00</u>					
SAMS TIRE SHOP, LLC	Revenue Fund	VO807452	140.00	EQUIPMENT REPAIRS	DCRAIG	RRV00349168	7/2/2024	140.00
		Check RRV00349168:	<u>140.00</u>					
SAMS TIRE SHOP, LLC	Revenue Fund	VO808014	100.00	EQUIPMENT REPAIRS	DCRAIG	RRV00349386	7/9/2024	100.00
		Check RRV00349386:	<u>100.00</u>					
SAMS TIRE SHOP, LLC	Revenue Fund	VO809368	14.00	EQUIPMENT REPAIRS	DCRAIG	RRV00349919	7/24/2024	42.00
		VO809370	14.00	EQUIPMENT REPAIRS	DCRAIG			
		VO809371	14.00	EQUIPMENT REPAIRS	DCRAIG			
		Check RRV00349919:	<u>42.00</u>					
		<b>Total for SAMS TIRE SHOP, LLC:</b>	<u>282.00</u>					
SAND SPRINGS TAG AGENCY - #7265	Revenue Fund	VO808318	212.50	FEE/ISSUANCE 85 PIKEPASS 06/2024	APERINGO	RRV00349591	7/11/2024	212.50
		Check RRV00349591:	<u>212.50</u>					
		<b>Total for SAND SPRINGS TAG AGENCY - #7265:</b>	<u>212.50</u>					
SAPULPA TAG OFFICE - SEAN SOWEL	Revenue Fund	VO808320	185.00	FEE/ISSUANCE 74 PIKEPASS 06/2024	APERINGO	RRV00349592	7/11/2024	185.00
		Check RRV00349592:	<u>185.00</u>					
		<b>Total for SAPULPA TAG OFFICE - SEAN SOWEL #1921:</b>	<u>185.00</u>					
SAYRE TAG AGENCY	Revenue Fund	VO808323	32.50	FEE/ISSUANCE 13 PIKEPASS 06/2024	APERINGO	RRV00349593	7/11/2024	32.50
		Check RRV00349593:	<u>32.50</u>					
		<b>Total for SAYRE TAG AGENCY:</b>	<u>32.50</u>					
SCOVIL AND SIDES HARDWARE CO	Revenue Fund	VO809865	1,895.00	OTHER COMMODITIES	MCOLLINS	RRV00350043	7/29/2024	1,895.00

Vendor Name	Fund Desc	Voucher NO.	Amt Applied	Description	Approver	Check No.	Date Paid	Amt Check
		Check RRV00350043:	1,895.00					
		<b>Total for SCOVIL AND SIDES HARDWARE CO:</b>	<b>1,895.00</b>					
SEMINOLE TAG AGENCY	Revenue Fund	VO808325	67.50	FEE/ISSUANCE 27 PIKEPASS 06/2024	APERINGO	RRV00349594	7/11/2024	67.50
		Check RRV00349594:	67.50					
		<b>Total for SEMINOLE TAG AGENCY:</b>	<b>67.50</b>					
SEQUOYAH TECHNOLOGIES LLC	General	VO809412	16,800.00	OTHER PROFESSIONAL SVCS ; 2405	DMA4TGAT	GEN00021512	7/24/2024	16,800.00
		Check GEN00021512:	16,800.00					
		<b>Total for SEQUOYAH TECHNOLOGIES LLC:</b>	<b>16,800.00</b>					
SERVICE OKLAHOMA	Revenue Fund	VO809017	12.66	GOV PERMITS & LICENSES	SALLEN	RRV00349851	7/18/2024	12.66
		Check RRV00349851:	12.66					
SERVICE OKLAHOMA	Revenue Fund	VO810076	40.00	GOV PERMITS & LICENSES	JSMITH	RRV00350093	7/31/2024	40.00
		Check RRV00350093:	40.00					
		<b>Total for SERVICE OKLAHOMA:</b>	<b>52.66</b>					
SEXTON, STEVEN R.	Revenue Fund	VO808036	56.50	JULY 2024 EXPENSES	RDTAYLOR	RRV00349390	7/9/2024	56.50
		Check RRV00349390:	56.50					
		<b>Total for SEXTON, STEVEN R.:</b>	<b>56.50</b>					
SHANE BURK GLASS & MIRROR OF L	Revenue Fund	VO808327	40.00	FEE/ISSUANCE 16 PIKEPASS 06/2024	APERINGO	RRV00349595	7/11/2024	40.00
		Check RRV00349595:	40.00					
		<b>Total for SHANE BURK GLASS &amp; MIRROR OF LAWTON:</b>	<b>40.00</b>					
SHAWNEE NORTH TAG - MICHELLE T	Revenue Fund	VO808329	42.50	FEE/ISSUANCE 17 PIKEPASS 06/2024	APERINGO	RRV00349596	7/11/2024	42.50
		Check RRV00349596:	42.50					
		<b>Total for SHAWNEE NORTH TAG - MICHELLE TERRELL:</b>	<b>42.50</b>					
SHAWNEE TAG AGENCY	Revenue Fund	VO808331	115.00	FEE/ISSUANCE 46 PIKEPASS 06/2024	APERINGO	RRV00349597	7/11/2024	115.00
		Check RRV00349597:	115.00					
		<b>Total for SHAWNEE TAG AGENCY:</b>	<b>115.00</b>					
SHELL CREEK RWD #12	Revenue Fund	VO807654	327.40	ACCT#2 WATER & METER CHARGE	BPATTERS	RRV00349245	7/3/2024	327.40
		Check RRV00349245:	327.40					
		<b>Total for SHELL CREEK RWD #12:</b>	<b>327.40</b>					
SHERWOOD CONSTRUCTION COMP	Capital Projects	VO808156	57,131.60	T-MC-128C: ESTIMATE NO. 9	TJDILL	23A0000225	7/9/2024	57,131.60
		Check 23A0000225:	57,131.60					
SHERWOOD CONSTRUCTION COMP	Capital Projects	VO808730	376,691.95	T-MC-131: ESTIMATE NO. 3	TJD4JECH	23A0000226	7/15/2024	376,691.95
		Check 23A0000226:	376,691.95					
SHERWOOD CONSTRUCTION COMP	General	VO808158	2,910.36	T-MC-128C: ESTIMATE NO. 9	TJDILL	GEN00021458	7/9/2024	2,910.36
		Check GEN00021458:	2,910.36					
SHERWOOD CONSTRUCTION COMP	General	VO808726	195,849.14	T-MC-131: ESTIMATE NO. 3	TJDILL	GEN00021478	7/15/2024	195,849.14
		Check GEN00021478:	195,849.14					
		<b>Total for SHERWOOD CONSTRUCTION COMPANY, INC.:</b>	<b>632,583.05</b>					
SHI INTERNATIONAL CORP.	General	VO806920	19,715.97	RADIOS & COMM EQUIP ; B18342862	MLOEFFEL	GEN00021446	7/3/2024	19,715.97
		Check GEN00021446:	19,715.97					

Vendor Name	Fund Desc	Voucher NO.	Amt Applied	Description	Approver	Check No.	Date Paid	Amt Check
SHI INTERNATIONAL CORP.	General	VO808527	<u>11,197.49</u>	ANNUAL SFTWR RENEW & SUB ; B18438004	MLOEFFEL	GEN00021472	7/12/2024	11,197.49
		Check GEN00021472:	11,197.49					
SHI INTERNATIONAL CORP.	Revenue Fund	VO807663	<u>43,952.21</u>	LEASEQUERY RENEW, GASB 87/96;B18290569	ABOULDEN	REV00016025	7/3/2024	43,952.21
		Check REV00016025:	43,952.21					
SHI INTERNATIONAL CORP.	Revenue Fund	VO807206	<u>13,752.90</u>	ANNUAL SFTWR RENEW&SUB; B18436024	ABOULDEN	REV00016036	7/15/2024	13,752.90
		Check REV00016036:	13,752.90					
SHI INTERNATIONAL CORP.	Revenue Fund	VO809665	<u>14,921.50</u>	ANNUAL SFTWR RENEW / SUB ; B18517175	ABOULDEN	REV00016074	7/26/2024	14,921.50
		Check REV00016074:	14,921.50					
<b>Total for SHI INTERNATIONAL CORP.:</b>			<b>103,540.07</b>					
SIDEJOB, INC.	General	VO807250	3,185.20	OTHER PROFESSIONAL SVCS ; 6710	DMA4TGAT	GEN00021442	7/3/2024	100,348.83
		VO807254	3,325.88	OTHER PROFESSIONAL SVCS ; 6714	DMA4TGAT			
		VO807259	2,000.00	OTHER PROFESSIONAL SVCS ; 6719	DMA4TGAT			
		VO807261	1,800.00	OTHER PROFESSIONAL SVCS ; 6721	DMA4TGAT			
		VO807263	1,800.00	OTHER PROFESSIONAL SVCS ; 6723	JECHELLE			
		VO807268	2,120.40	OTHER PROFESSIONAL SVCS ; 6728	DMA4TGAT			
		VO807269	2,099.20	OTHER PROFESSIONAL SVCS ; 6729	DMA4TGAT			
		VO807272	2,679.60	OTHER PROFESSIONAL SVCS ; 6732	DMA4TGAT			
		VO807276	1,824.80	OTHER PROFESSIONAL SVCS ; 6736	DMA4TGAT			
		VO807280	1,647.36	OTHER PROFESSIONAL SVCS ; 6740	DMA4TGAT			
		VO807283	3,000.00	OTHER PROFESSIONAL SVCS ; 6743	JECHELLE			
		VO807285	1,580.00	OTHER PROFESSIONAL SVCS ; 6745	DMA4TGAT			
		VO807290	3,840.00	OTHER PROFESSIONAL SVCS ; 6751	DMA4TGAT			
		VO807247	1,727.86	OTHER PROFESSIONAL SVCS ; 6707	DMA4TGAT			
		VO807249	1,520.00	OTHER PROFESSIONAL SVCS ; 6709	DMA4TGAT			
		VO807255	807.03	OTHER PROFESSIONAL SVCS ; 6715	DMA4TGAT			
		VO807257	1,600.00	OTHER PROFESSIONAL SVCS ; 6717	DMA4TGAT			
		VO807260	3,744.00	OTHER PROFESSIONAL SVCS ; 6720	DMA4TGAT			
		VO807264	1,408.00	OTHER PROFESSIONAL SVCS ; 6724	DMA4TGAT			
		VO807267	1,671.20	OTHER PROFESSIONAL SVCS ; 6727	DMA4TGAT			
		VO807275	1,999.71	OTHER PROFESSIONAL SVCS ; 6735	DMA4TGAT			
		VO807277	2,419.20	OTHER PROFESSIONAL SVCS ; 6737	DMA4TGAT			
		VO807278	1,724.00	OTHER PROFESSIONAL SVCS ; 6738	DMA4TGAT			
		VO807282	1,840.00	OTHER PROFESSIONAL SVCS ; 6742	DMA4TGAT			
		VO807284	3,240.00	OTHER PROFESSIONAL SVCS ; 6744	DMA4TGAT			
		VO807287	2,583.75	OTHER PROFESSIONAL SVCS ; 6747	ABOULDEN			
		VO807288	1,408.00	OTHER PROFESSIONAL SVCS ; 6748	DMA4TGAT			
		VO807289	4,000.00	OTHER PROFESSIONAL SVCS ; 6750	DMA4TGAT			
		VO807291	1,626.80	OTHER PROFESSIONAL SVCS ; 6752	DMA4TGAT			
		VO807248	3,991.60	OTHER PROFESSIONAL SVCS ; 6708	DMA4TGAT			
		VO807251	1,320.00	OTHER PROFESSIONAL SVCS ; 6711	DMA4TGAT			
		VO807252	1,809.60	OTHER PROFESSIONAL SVCS ; 6712	DMA4TGAT			
		VO807253	4,445.20	OTHER PROFESSIONAL SVCS ; 6713	DMA4TGAT			
VO807256	2,649.60	OTHER PROFESSIONAL SVCS ; 6716	DMA4TGAT					
VO807258	1,485.00	OTHER PROFESSIONAL SVCS ; 6718	DMA4TGAT					
VO807262	1,353.28	OTHER PROFESSIONAL SVCS ; 6722	DMA4TGAT					
VO807265	3,486.00	OTHER PROFESSIONAL SVCS ; 6725	DMA4TGAT					
VO807266	1,760.00	OTHER PROFESSIONAL SVCS ; 6726	DMA4TGAT					
VO807270	2,659.20	OTHER PROFESSIONAL SVCS ; 6730	DMA4TGAT					
VO807271	2,000.00	OTHER PROFESSIONAL SVCS ; 6731	DMA4TGAT					
VO807273	1,728.00	OTHER PROFESSIONAL SVCS ; 6733	DMA4TGAT					

Vendor Name	Fund Desc	Voucher NO.	Amt Applied	Description	Approver	Check No.	Date Paid	Amt Check
		VO807274	1,860.00	OTHER PROFESSIONAL SVCS ; 6734	DMA4TGAT			
		VO807279	1,135.36	OTHER PROFESSIONAL SVCS ; 6739	DMA4TGAT			
		VO807281	3,324.00	OTHER PROFESSIONAL SVCS ; 6741	DMA4TGAT			
		VO807286	1,120.00	OTHER PROFESSIONAL SVCS ; 6746	DMA4TGAT			
		Check GEN00021442:	100,348.83					
SIDEJOB, INC.	General	VO807953	1,818.80	OTHER PROFESSIONAL SVCS ; 6755	DMA4TGAT	GEN00021456	7/9/2024	102,244.51
		VO807967	1,800.00	OTHER PROFESSIONAL SVCS ; 6766	DMA4TGAT			
		VO807975	1,800.00	OTHER PROFESSIONAL SVCS ; 6771	JECHELLE			
		VO807985	2,856.00	OTHER PROFESSIONAL SVCS ; 6773	DMA4TGAT			
		VO807997	1,934.40	OTHER PROFESSIONAL SVCS ; 6776	DMA4TGAT			
		VO808000	2,659.20	OTHER PROFESSIONAL SVCS ; 6778	DMA4TGAT			
		VO808002	1,900.00	OTHER PROFESSIONAL SVCS ; 6779	DMA4TGAT			
		VO808004	1,920.00	OTHER PROFESSIONAL SVCS ; 6781	DMA4TGAT			
		VO808007	1,824.80	OTHER PROFESSIONAL SVCS ; 6784	DMA4TGAT			
		VO808030	1,724.00	OTHER PROFESSIONAL SVCS ; 6786	DMA4TGAT			
		VO808032	1,419.20	OTHER PROFESSIONAL SVCS ; 6787	DMA4TGAT			
		VO808043	1,840.00	OTHER PROFESSIONAL SVCS ; 6790	DMA4TGAT			
		VO808045	3,000.00	OTHER PROFESSIONAL SVCS ; 6791	JECHELLE			
		VO808047	3,240.00	OTHER PROFESSIONAL SVCS ; 6792	DMA4TGAT			
		VO808050	1,120.00	OTHER PROFESSIONAL SVCS ; 6794	DMA4TGAT			
		VO808058	1,626.80	OTHER PROFESSIONAL SVCS ; 6800	DMA4TGAT			
		VO807956	1,520.00	OTHER PROFESSIONAL SVCS ; 6757	DMA4TGAT			
		VO807963	3,801.00	OTHER PROFESSIONAL SVCS ; 6762	DMA4TGAT			
		VO807964	1,537.20	OTHER PROFESSIONAL SVCS ; 6763	DMA4TGAT			
		VO807965	2,649.60	OTHER PROFESSIONAL SVCS ; 6764	DMA4TGAT			
		VO807973	1,691.60	OTHER PROFESSIONAL SVCS ; 6770	DMA4TGAT			
		VO807983	1,496.00	OTHER PROFESSIONAL SVCS ; 6772	DMA4TGAT			
		VO807996	1,671.20	OTHER PROFESSIONAL SVCS ; 6775	DMA4TGAT			
		VO807999	2,099.20	OTHER PROFESSIONAL SVCS ; 6777	DMA4TGAT			
		VO808003	2,598.40	OTHER PROFESSIONAL SVCS ; 6780	DMA4TGAT			
		VO808048	1,580.00	OTHER PROFESSIONAL SVCS ; 6793	DMA4TGAT			
		VO808052	2,600.00	OTHER PROFESSIONAL SVCS ; 6795	ABOULDEN			
		VO808053	1,760.00	OTHER PROFESSIONAL SVCS ; 6796	DMA4TGAT			
		VO807955	3,991.60	OTHER PROFESSIONAL SVCS ; 6756	DMA4TGAT			
		VO807957	3,185.20	OTHER PROFESSIONAL SVCS ; 6758	DMA4TGAT			
		VO807960	1,280.00	OTHER PROFESSIONAL SVCS ; 6759	DMA4TGAT			
		VO807961	1,809.60	OTHER PROFESSIONAL SVCS ; 6760	DMA4TGAT			
		VO807962	4,445.20	OTHER PROFESSIONAL SVCS ; 6761	DMA4TGAT			
		VO807966	1,600.00	OTHER PROFESSIONAL SVCS ; 6765	DMA4TGAT			
		VO807968	2,000.00	OTHER PROFESSIONAL SVCS ; 6767	DMA4TGAT			
		VO807969	3,744.00	OTHER PROFESSIONAL SVCS ; 6768	DMA4TGAT			
		VO807972	2,000.00	OTHER PROFESSIONAL SVCS ; 6769	DMA4TGAT			
		VO807995	2,200.00	OTHER PROFESSIONAL SVCS ; 6774	DMA4TGAT			
		VO808005	1,116.00	OTHER PROFESSIONAL SVCS ; 6782	DMA4TGAT			
		VO808006	2,051.99	OTHER PROFESSIONAL SVCS ; 6783	DMA4TGAT			
		VO808008	2,419.20	OTHER PROFESSIONAL SVCS ; 6785	DMA4TGAT			
		VO808033	1,750.32	OTHER PROFESSIONAL SVCS ; 6788	DMA4TGAT			
		VO808040	3,324.00	OTHER PROFESSIONAL SVCS ; 6789	DMA4TGAT			
		VO808055	4,000.00	OTHER PROFESSIONAL SVCS ; 6798	DMA4TGAT			
		VO808056	3,840.00	OTHER PROFESSIONAL SVCS ; 6799	DMA4TGAT			
		Check GEN00021456:	102,244.51					
SIDEJOB, INC.	General	VO808647	3,185.20	OTHER PROFESSIONAL SVCS ; 6806	DMA4TGAT	GEN00021482	7/15/2024	104,515.72



Vendor Name	Fund Desc	Voucher NO.	Amt Applied	Description	Approver	Check No.	Date Paid	Amt Check
		VO808649	1,809.60	OTHER PROFESSIONAL SVCS ; 6808	DMA4TGAT			
		VO808736	2,000.00	OTHER PROFESSIONAL SVCS ; 6815	DMA4TGAT			
		VO808738	1,650.00	OTHER PROFESSIONAL SVCS ; 6817	DMA4TGAT			
		VO808739	1,691.60	OTHER PROFESSIONAL SVCS ; 6818	DMA4TGAT			
		VO808758	2,035.00	OTHER PROFESSIONAL SVCS ; 6822	DMA4TGAT			
		VO808759	1,671.20	OTHER PROFESSIONAL SVCS ; 6823	DMA4TGAT			
		VO808762	1,636.80	OTHER PROFESSIONAL SVCS ; 6824	DMA4TGAT			
		VO808764	2,099.20	OTHER PROFESSIONAL SVCS ; 6825	DMA4TGAT			
		VO808767	2,493.00	OTHER PROFESSIONAL SVCS ; 6826	DMA4TGAT			
		VO808773	1,860.00	OTHER PROFESSIONAL SVCS ; 6830	DMA4TGAT			
		VO808775	1,824.80	OTHER PROFESSIONAL SVCS ; 6832	DMA4TGAT			
		VO808789	1,840.00	OTHER PROFESSIONAL SVCS ; 6838	DMA4TGAT			
		VO808645	3,991.60	OTHER PROFESSIONAL SVCS ; 6804	DMA4TGAT			
		VO808646	1,520.00	OTHER PROFESSIONAL SVCS ; 6805	DMA4TGAT			
		VO808648	1,400.00	OTHER PROFESSIONAL SVCS ; 6807	DMA4TGAT			
		VO808732	1,537.20	OTHER PROFESSIONAL SVCS ; 6811	DMA4TGAT			
		VO808737	3,744.00	OTHER PROFESSIONAL SVCS ; 6816	DMA4TGAT			
		VO808740	1,800.00	OTHER PROFESSIONAL SVCS ; 6819	JECHELLE			
		VO808742	1,628.00	OTHER PROFESSIONAL SVCS ; 6820	DMA4TGAT			
		VO808768	1,900.00	OTHER PROFESSIONAL SVCS ; 6827	DMA4TGAT			
		VO808769	3,248.00	OTHER PROFESSIONAL SVCS ; 6828	DMA4TGAT			
		VO808774	2,038.92	OTHER PROFESSIONAL SVCS ; 6831	DMA4TGAT			
		VO808777	2,419.20	OTHER PROFESSIONAL SVCS ; 6833	DMA4TGAT			
		VO808778	1,724.00	OTHER PROFESSIONAL SVCS ; 6834	DMA4TGAT			
		VO808787	3,324.00	OTHER PROFESSIONAL SVCS ; 6837	DMA4TGAT			
		VO808792	3,000.00	OTHER PROFESSIONAL SVCS ; 6839	JECHELLE			
		VO808798	760.00	OTHER PROFESSIONAL SVCS ; 6842	DMA4TGAT			
		VO808800	2,567.50	OTHER PROFESSIONAL SVCS ; 6844	ABOULDEN			
		VO808802	1,760.00	OTHER PROFESSIONAL SVCS ; 6845	DMA4TGAT			
		VO808805	3,840.00	OTHER PROFESSIONAL SVCS ; 6848	DMA4TGAT			
		VO808644	1,818.80	OTHER PROFESSIONAL SVCS ; 6803	DMA4TGAT			
		VO808650	4,445.20	OTHER PROFESSIONAL SVCS ; 6809	DMA4TGAT			
		VO808651	3,597.38	OTHER PROFESSIONAL SVCS ; 6810	DMA4TGAT			
		VO808733	2,649.60	OTHER PROFESSIONAL SVCS ; 6812	DMA4TGAT			
		VO808734	1,600.00	OTHER PROFESSIONAL SVCS ; 6813	DMA4TGAT			
		VO808735	1,530.00	OTHER PROFESSIONAL SVCS ; 6814	DMA4TGAT			
		VO808757	4,452.00	OTHER PROFESSIONAL SVCS ; 6821	DMA4TGAT			
		VO808772	1,920.00	OTHER PROFESSIONAL SVCS ; 6829	DMA4TGAT			
		VO808782	1,419.20	OTHER PROFESSIONAL SVCS ; 6835	DMA4TGAT			
		VO808785	1,750.32	OTHER PROFESSIONAL SVCS ; 6836	DMA4TGAT			
		VO808794	3,240.00	OTHER PROFESSIONAL SVCS ; 6840	DMA4TGAT			
		VO808797	1,580.00	OTHER PROFESSIONAL SVCS ; 6841	DMA4TGAT			
		VO808799	1,120.00	OTHER PROFESSIONAL SVCS ; 6843	DMA4TGAT			
		VO808804	4,000.00	OTHER PROFESSIONAL SVCS ; 6847	DMA4TGAT			
		VO808806	1,394.40	OTHER PROFESSIONAL SVCS ; 6849	DMA4TGAT			
		Check GEN00021482:	104,515.72					
SIDEJOB, INC.	General	VO808856	3,991.60	OTHER PROFESSIONAL SVCS ; 6853	DMA4TGAT	GEN00021486	7/17/2024	96,106.84
		VO808857	1,520.00	OTHER PROFESSIONAL SVCS ; 6854	DMA4TGAT			
		VO808860	1,320.00	OTHER PROFESSIONAL SVCS ; 6856	DMA4TGAT			
		VO808868	2,000.00	OTHER PROFESSIONAL SVCS ; 6864	DMA4TGAT			
		VO808924	1,800.00	OTHER PROFESSIONAL SVCS ; 6867	JECHELLE			
		VO808925	1,760.00	OTHER PROFESSIONAL SVCS ; 6868	DMA4TGAT			
		VO808926	2,688.00	OTHER PROFESSIONAL SVCS ; 6869	DMA4TGAT			

Vendor Name	Fund Desc	Voucher NO.	Amt Applied	Description	Approver	Check No.	Date Paid	Amt Check
		VO808927	2,200.00	OTHER PROFESSIONAL SVCS ; 6870	DMA4TGAT			
		VO808933	3,166.80	OTHER PROFESSIONAL SVCS ; 6876	DMA4TGAT			
		VO808939	1,693.44	OTHER PROFESSIONAL SVCS ; 6881	DMA4TGAT			
		VO808940	1,724.00	OTHER PROFESSIONAL SVCS ; 6882	DMA4TGAT			
		VO808948	1,120.00	OTHER PROFESSIONAL SVCS ; 6890	DMA4TGAT			
		VO808949	1,760.00	OTHER PROFESSIONAL SVCS ; 6892	DMA4TGAT			
		VO808951	3,840.00	OTHER PROFESSIONAL SVCS ; 6895	DMA4TGAT			
		VO808952	1,626.80	OTHER PROFESSIONAL SVCS ; 6896	DMA4TGAT			
		VO808855	1,682.39	OTHER PROFESSIONAL SVCS ; 6852	DMA4TGAT			
		VO808864	3,461.63	OTHER PROFESSIONAL SVCS ; 6859	DMA4TGAT			
		VO808923	1,691.60	OTHER PROFESSIONAL SVCS ; 6866	DMA4TGAT			
		VO808931	2,659.20	OTHER PROFESSIONAL SVCS ; 6874	DMA4TGAT			
		VO808937	2,065.06	OTHER PROFESSIONAL SVCS ; 6879	DMA4TGAT			
		VO808944	1,840.00	OTHER PROFESSIONAL SVCS ; 6886	DMA4TGAT			
		VO808946	3,240.00	OTHER PROFESSIONAL SVCS ; 6888	DMA4TGAT			
		VO808859	3,185.20	OTHER PROFESSIONAL SVCS ; 6855	DMA4TGAT			
		VO808862	1,809.60	OTHER PROFESSIONAL SVCS ; 6857	DMA4TGAT			
		VO808863	4,445.20	OTHER PROFESSIONAL SVCS ; 6858	DMA4TGAT			
		VO808865	1,537.20	OTHER PROFESSIONAL SVCS ; 6860	DMA4TGAT			
		VO808866	2,649.60	OTHER PROFESSIONAL SVCS ; 6861	DMA4TGAT			
		VO808867	1,800.00	OTHER PROFESSIONAL SVCS ; 6863	DMA4TGAT			
		VO808869	3,744.00	OTHER PROFESSIONAL SVCS ; 6865	DMA4TGAT			
		VO808928	1,671.20	OTHER PROFESSIONAL SVCS ; 6871	DMA4TGAT			
		VO808929	2,008.80	OTHER PROFESSIONAL SVCS ; 6872	DMA4TGAT			
		VO808930	2,099.20	OTHER PROFESSIONAL SVCS ; 6873	DMA4TGAT			
		VO808932	2,000.00	OTHER PROFESSIONAL SVCS ; 6875	DMA4TGAT			
		VO808934	1,920.00	OTHER PROFESSIONAL SVCS ; 6877	DMA4TGAT			
		VO808935	1,488.00	OTHER PROFESSIONAL SVCS ; 6878	DMA4TGAT			
		VO808938	1,824.80	OTHER PROFESSIONAL SVCS ; 6880	DMA4TGAT			
		VO808941	1,419.20	OTHER PROFESSIONAL SVCS ; 6883	DMA4TGAT			
		VO808942	1,750.32	OTHER PROFESSIONAL SVCS ; 6884	DMA4TGAT			
		VO808943	3,324.00	OTHER PROFESSIONAL SVCS ; 6885	DMA4TGAT			
		VO808945	3,000.00	OTHER PROFESSIONAL SVCS ; 6887	JECHELLE			
		VO808947	1,580.00	OTHER PROFESSIONAL SVCS ; 6889	DMA4TGAT			
		VO808950	4,000.00	OTHER PROFESSIONAL SVCS ; 6894	DMA4TGAT			
		Check GEN00021486:	96,106.84					
SIDEJOB, INC.	General	VO809426	3,991.60	OTHER PROFESSIONAL SVCS ; 6900	DMA4TGAT	GEN00021513	7/24/2024	101,674.23
		VO809437	1,537.20	OTHER PROFESSIONAL SVCS ; 6907	DMA4TGAT			
		VO809449	2,000.00	OTHER PROFESSIONAL SVCS ; 6911	DMA4TGAT			
		VO809456	3,444.00	OTHER PROFESSIONAL SVCS ; 6916	DMA4TGAT			
		VO809460	2,678.40	OTHER PROFESSIONAL SVCS ; 6919	DMA4TGAT			
		VO809461	2,099.20	OTHER PROFESSIONAL SVCS ; 6920	DMA4TGAT			
		VO809465	3,248.00	OTHER PROFESSIONAL SVCS ; 6923	DMA4TGAT			
		VO809470	1,824.80	OTHER PROFESSIONAL SVCS ; 6927	DMA4TGAT			
		VO809471	2,419.20	OTHER PROFESSIONAL SVCS ; 6928	DMA4TGAT			
		VO809474	1,348.24	OTHER PROFESSIONAL SVCS ; 6930	DMA4TGAT			
		VO809476	3,324.00	OTHER PROFESSIONAL SVCS ; 6932	DMA4TGAT			
		VO809479	3,240.00	OTHER PROFESSIONAL SVCS ; 6935	DMA4TGAT			
		VO809486	4,000.00	OTHER PROFESSIONAL SVCS ; 6941	DMA4TGAT			
		VO809488	1,394.40	OTHER PROFESSIONAL SVCS ; 6943	DMA4TGAT			
		VO809433	1,809.60	OTHER PROFESSIONAL SVCS ; 6904	DMA4TGAT			
		VO809445	1,600.00	OTHER PROFESSIONAL SVCS ; 6909	DMA4TGAT			
		VO809447	1,777.50	OTHER PROFESSIONAL SVCS ; 6910	DMA4TGAT			

Vendor Name	Fund Desc	Voucher NO.	Amt Applied	Description	Approver	Check No.	Date Paid	Amt Check
		VO809452	1,691.60	OTHER PROFESSIONAL SVCS ; 6913	DMA4TGAT			
		VO809453	1,800.00	OTHER PROFESSIONAL SVCS ; 6914	JECHELLE			
		VO809459	1,671.20	OTHER PROFESSIONAL SVCS ; 6918	DMA4TGAT			
		VO809466	1,920.00	OTHER PROFESSIONAL SVCS ; 6924	DMA4TGAT			
		VO809468	1,860.00	OTHER PROFESSIONAL SVCS ; 6925	DMA4TGAT			
		VO809472	1,724.00	OTHER PROFESSIONAL SVCS ; 6929	DMA4TGAT			
		VO809478	3,000.00	OTHER PROFESSIONAL SVCS ; 6934	JECHELLE			
		VO809482	1,580.00	OTHER PROFESSIONAL SVCS ; 6936	DMA4TGAT			
		VO809424	1,727.86	OTHER PROFESSIONAL SVCS ; 6899	DMA4TGAT			
		VO809427	1,520.00	OTHER PROFESSIONAL SVCS ; 6901	DMA4TGAT			
		VO809429	2,548.16	OTHER PROFESSIONAL SVCS ; 6902	DMA4TGAT			
		VO809430	1,360.00	OTHER PROFESSIONAL SVCS ; 6903	DMA4TGAT			
		VO809434	4,445.20	OTHER PROFESSIONAL SVCS ; 6905	DMA4TGAT			
		VO809435	3,190.13	OTHER PROFESSIONAL SVCS ; 6906	DMA4TGAT			
		VO809443	2,649.60	OTHER PROFESSIONAL SVCS ; 6908	DMA4TGAT			
		VO809450	3,744.00	OTHER PROFESSIONAL SVCS ; 6912	DMA4TGAT			
		VO809455	1,760.00	OTHER PROFESSIONAL SVCS ; 6915	DMA4TGAT			
		VO809458	2,145.00	OTHER PROFESSIONAL SVCS ; 6917	DMA4TGAT			
		VO809462	2,625.96	OTHER PROFESSIONAL SVCS ; 6921	DMA4TGAT			
		VO809464	2,000.00	OTHER PROFESSIONAL SVCS ; 6922	DMA4TGAT			
		VO809469	2,065.06	OTHER PROFESSIONAL SVCS ; 6926	DMA4TGAT			
		VO809475	1,750.32	OTHER PROFESSIONAL SVCS ; 6931	DMA4TGAT			
		VO809477	1,840.00	OTHER PROFESSIONAL SVCS ; 6933	DMA4TGAT			
		VO809483	1,120.00	OTHER PROFESSIONAL SVCS ; 6937	DMA4TGAT			
		VO809487	3,840.00	OTHER PROFESSIONAL SVCS ; 6942	DMA4TGAT			
		VO809484	2,600.00	OTHER PROFESSIONAL SVCS ; 6938	ABOULDEN			
		VO809485	1,760.00	OTHER PROFESSIONAL SVCS ; 6939	DMA4TGAT			
		Check GEN00021513:	101,674.23					
SIDEJOB, INC.	Revenue Fund	VO808339	1,800.00	OTHER PROFESSIONAL SERVICES	PWILLIAM	RRV00349621	7/11/2024	1,800.00
		Check RRV00349621:	1,800.00					
SIDEJOB, INC.	Revenue Fund	VO808699	1,800.00	OTHER PROFESSIONAL SERVICES	PWILLIAM	RRV00349892	7/19/2024	1,800.00
		Check RRV00349892:	1,800.00					
SIDEJOB, INC.	Revenue Fund	VO809375	1,800.00	OTHER PROFESSIONAL SERVICES	DMA4TGAT	RRV00349920	7/24/2024	1,800.00
		Check RRV00349920:	1,800.00					
SIDEJOB, INC.	Revenue Fund	VO809868	1,800.00	OTHER PROFESSIONAL SERVICES	DMA4TGAT	RRV00350044	7/29/2024	1,800.00
		Check RRV00350044:	1,800.00					
		<b>Total for SIDEJOB, INC.:</b>	<b>512,090.13</b>					
SIGNS BY JADE	Revenue Fund	VO809870	60.00	VEHICLE PARTS AND SUPPLIES	BWESTER	RRV00350045	7/29/2024	60.00
		Check RRV00350045:	60.00					
		<b>Total for SIGNS BY JADE:</b>	<b>60.00</b>					
SKIATOOK TAG AGENCY	Revenue Fund	VO808333	70.00	FEE/ISSUANCE 28 PIKEPASS 06/2024	APERINGO	RRV00349598	7/11/2024	70.00
		Check RRV00349598:	70.00					
		<b>Total for SKIATOOK TAG AGENCY:</b>	<b>70.00</b>					
SKYWAY HONDA	Revenue Fund	VO808336	22.50	FEE/ISSUANCE 9 PIKEPASS 06/2024	APERINGO	RRV00349599	7/11/2024	22.50
		Check RRV00349599:	22.50					
		<b>Total for SKYWAY HONDA:</b>	<b>22.50</b>					

Vendor Name	Fund Desc	Voucher NO.	Amt Applied	Description	Approver	Check No.	Date Paid	Amt Check
SMITH FARM AND GARDEN - 5606	Revenue Fund	VO809379	76.57	EQUIPMENT PARTS	DCRAIG	RRV00349921	7/24/2024	76.57
		Check RRV00349921:	76.57					
SMITH FARM AND GARDEN - 5606	Revenue Fund	VO809871	39.50	EQUIPMENT PARTS	DCRAIG	RRV00350046	7/29/2024	39.50
		Check RRV00350046:	39.50					
<b>Total for SMITH FARM AND GARDEN - 5606:</b>			<b>116.07</b>					
SMITH ROBERTS BALDISCHWILER, LL General		VO809917	28,297.80	C-MC-30: LABR/TRP/TEST: 55973	TJDILL	GEN00021534	7/29/2024	28,297.80
		Check GEN00021534:	28,297.80					
SMITH ROBERTS BALDISCHWILER, LL Reserve Maintenance		VO810069	5,000.00	AS BLT RECORD PLANS, T-MC-137 ; 55963	TJD4JECH	RMT00006059	7/30/2024	5,000.00
		Check RMT00006059:	5,000.00					
<b>Total for SMITH ROBERTS BALDISCHWILER, LLC:</b>			<b>33,297.80</b>					
SMITH, MELISA D.	Revenue Fund	VO808130	37.63	JULY 2024 EXPENSES	KINMAN	RRV00349458	7/9/2024	37.63
		Check RRV00349458:	37.63					
<b>Total for SMITH, MELISA D.:</b>			<b>37.63</b>					
SNYDER TAG AGENCY	Revenue Fund	VO808338	27.50	FEE/ISSUANCE 11 PIKEPASS 06/2024	APERINGO	RRV00349600	7/11/2024	27.50
		Check RRV00349600:	27.50					
<b>Total for SNYDER TAG AGENCY:</b>			<b>27.50</b>					
SOFTCHOICE CORPORATION	General	VO808529	395.97	NON-CAP SOFTWARE ; 91389473	MLOEFFEL	GEN00021473	7/12/2024	395.97
		Check GEN00021473:	395.97					
<b>Total for SOFTCHOICE CORPORATION:</b>			<b>395.97</b>					
SOONER FOODS INC.	Revenue Fund	VO808343	40.03	SAFETY SUPPLIES; OTHER COMMODITIES	CSTEVENS	RRV00349622	7/11/2024	40.03
		Check RRV00349622:	40.03					
SOONER FOODS INC.	Revenue Fund	VO808700	56.94	EMPLOYEE INCENTIVE - FOOD/CATERING	CSTEVENS	RRV00349791	7/17/2024	56.94
		Check RRV00349791:	56.94					
<b>Total for SOONER FOODS INC.:</b>			<b>96.97</b>					
SOONER ROAD TAG AGENCY	Revenue Fund	VO808341	52.50	FEE/ISSUANCE 21 PIKEPASS 06/2024	APERINGO	RRV00349601	7/11/2024	52.50
		Check RRV00349601:	52.50					
<b>Total for SOONER ROAD TAG AGENCY:</b>			<b>52.50</b>					
SOONER WIPING RAGS LLC	Revenue Fund	VO809872	192.50	CLEANING & JANITORIAL SUPPLIES	DCRAIG	RRV00350047	7/29/2024	192.50
		Check RRV00350047:	192.50					
<b>Total for SOONER WIPING RAGS LLC:</b>			<b>192.50</b>					
SOUTHERN DISPOSAL, INC.	Revenue Fund	VO809380	430.00	TRASH DISPOSAL	BWESTER	RRV00349922	7/24/2024	860.00
		VO809381	430.00	TRASH DISPOSAL				
		Check RRV00349922:	860.00					
<b>Total for SOUTHERN DISPOSAL, INC.:</b>			<b>860.00</b>					
SOUTHERN TIRE MART	Revenue Fund	VO807464	2,462.36	EQUIPMENT PARTS	MCOLLINS DCRAIG	RRV00349172	7/2/2024	3,252.56
		VO807465	790.20	VEHICLE PARTS				
		Check RRV00349172:	3,252.56					
SOUTHERN TIRE MART	Revenue Fund	VO808703	325.50	EQUIPMENT PARTS & SUPPLIES	DCRAIG PGOGGIN	RRV00349893	7/19/2024	520.89
		VO809134	195.39	VEHICLE PARTS; EQUIPMENT REPAIR				
		Check RRV00349893:	520.89					

Vendor Name	Fund Desc	Voucher NO.	Amt Applied	Description	Approver	Check No.	Date Paid	Amt Check
SOUTHERN TIRE MART	Revenue Fund	VO809389	741.00	VEHICLE PARTS	DCRAIG	RRV00349923	7/24/2024	741.00
		Check RRV00349923:	741.00					
SOUTHERN TIRE MART	Revenue Fund	VO809874	815.80	VEHICLE PARTS;EQUIPMENT REPAIRS	PGOGGIN	RRV00350051	7/29/2024	815.80
		Check RRV00350051:	815.80					
<b>Total for SOUTHERN TIRE MART:</b>			<b>5,330.25</b>					
SPARKLIGHT	Revenue Fund	VO808018	294.94	PHONE	JLYTLE	EFT018780	7/9/2024	294.94
		Check EFT018780:	294.94					
<b>Total for SPARKLIGHT:</b>			<b>294.94</b>					
SPIRO TAG AGENCY, LLC	Revenue Fund	VO808344	45.00	FEE/ISSUANCE 18 PIKEPASS 06/2024	APERINGO	RRV00349602	7/11/2024	45.00
		Check RRV00349602:	45.00					
<b>Total for SPIRO TAG AGENCY, LLC:</b>			<b>45.00</b>					
STANDARD AUTO PARTS OF BRISTOW, INC.	Revenue Fund	VO808347	25.98	PAINTING SUPPLIES	RDTAYLOR	RRV00349627	7/11/2024	25.98
		Check RRV00349627:	25.98					
<b>Total for STANDARD AUTO PARTS OF BRISTOW, INC.:</b>			<b>25.98</b>					
STANDARD MACHINE, L.L.C.	Revenue Fund	VO808707	432.00	SIGNING SUPPLIES	BELLIS	RRV00349798	7/17/2024	432.00
		Check RRV00349798:	432.00					
<b>Total for STANDARD MACHINE, L.L.C.:</b>			<b>432.00</b>					
STANDLEY SYSTEMS, INC.	Revenue Fund	VO808387	445.19	EQUIPMENT RENTAL	AHEITZ	RRV00349625	7/11/2024	4,750.37
		VO808389	654.33	EQUIPMENT RENTAL	AHEITZ			
		VO808390	107.41	EQUIPMENT RENTAL	AHEITZ			
		VO808393	502.70	EQUIPMENT RENTAL	BCANTREL			
		VO808382	545.50	EQUIPMENT RENTAL	JJENKINS			
		VO808385	482.90	EQUIPMENT RENTAL	PGOGGIN			
		VO808386	162.62	EQUIPMENT RENTAL	AHEITZ			
		VO808391	464.24	EQUIPMENT RENTAL	JMELTON			
		VO808394	485.26	EQUIPMENT RENTAL	KWALLIS			
		VO808349	445.23	EQUIPMENT RENTAL	CHUGHES			
		VO808388	454.99	EQUIPMENT RENTAL	AHEITZ			
Check RRV00349625:			4,750.37					
STANDLEY SYSTEMS, INC.	Revenue Fund	VO808395	3,948.35	EQUIPMENT RENTAL	JSMITH	RRV00349626	7/11/2024	3,948.35
		Check RRV00349626:	3,948.35					
STANDLEY SYSTEMS, INC.	Revenue Fund	VO808709	531.61	EQUIPMENT RENTAL - BASE AND OVERAGE	RDTAYLOR	RRV00349794	7/17/2024	2,212.09
		VO808714	860.88	EQUIPMENT RENTAL - BASE	DCRAIG			
		VO808999	409.80	EQUIPMENT RENTAL - BASE	DCRAIG			
		VO808715	409.80	EQUIPMENT RENTAL - BASE	RROWEN			
		Check RRV00349794:	2,212.09					
STANDLEY SYSTEMS, INC.	Revenue Fund	VO809311	373.72	EQUIPMENT RENTAL	TGORE	RRV00349902	7/22/2024	7,756.10
		VO809312	7,382.38	EQUIPMENT RENTAL	TGORE			
		Check RRV00349902:	7,756.10					
<b>Total for STANDLEY SYSTEMS, INC.:</b>			<b>18,666.91</b>					
STAPLES BUSINESS ADVANTAGE (AC)	Revenue Fund	VO808396	168.32	SAFETY & MEDICAL SUPPLIES	JJENKINS	RRV00349624	7/11/2024	168.32
		Check RRV00349624:	168.32					
STAPLES BUSINESS ADVANTAGE (AC)	Revenue Fund	VO807471	-7.66	OTHER COMMODITIES & SUPPLIES	JJENKINS	RRV00349723	7/12/2024	510.19

Vendor Name	Fund Desc	Voucher NO.	Amt Applied	Description	Approver	Check No.	Date Paid	Amt Check
		VO807476	22.09	CLEANING SUPPLIES	DCRAIG			
		VO807488	152.93	OTHER COMMOITIES & SUPPLIES	KWALLIS			
		VO808534	157.32	OTHER COMMODITIES & SUPPLIES	JJENKINS			
		VO807485	55.79	OFFICE SUPPLIES	BCANTREL			
		VO807490	40.52	OFFICE SUPPLIES	KWALLIS			
		VO808535	7.66	OFFICE SUPPLIES - DM REVERSAL	JJENKINS			
		VO807486	73.88	OFFICE SUPPLIES	DCRAIG			
		VO808524	7.66	OFFICE SUPPLIES	APERINGO			
		Check RRV00349723:	510.19					
STAPLES BUSINESS ADVANTAGE	(AC Revenue Fund)	VO808716	152.18	OFFICE SUPPLIES- OTHER COMODOTIES	TJDILL	RRV00349792	7/17/2024	159.15
		VO808717	6.97	OTHER COMMODITIES & SUPPLIES	TJDILL			
		Check RRV00349792:	159.15					
STAPLES BUSINESS ADVANTAGE	(AC Revenue Fund)	VO809580	174.08	OTHER COMMODITIES;OFFICE SUPPLIES	TJDILL	RRV00350014	7/26/2024	207.65
		VO809592	33.57	OTHER COMMODITIES & SUPPLIES	TJDILL			
		Check RRV00350014:	207.65					
STAPLES BUSINESS ADVANTAGE	(AC Revenue Fund)	VO809881	390.67	OFFICE SUPP; SAFETY SUPP; CLEANING SUPP	PGOGGIN	RRV00350048	7/29/2024	649.02
		VO809883	258.35	OFFICE SUPP;CLEANING SUPP; SAFETY SUPP	KWALLIS			
		Check RRV00350048:	649.02					
		<b>Total for STAPLES BUSINESS ADVANTAGE (ADV):</b>	<b>1,694.33</b>					
STATE OF OKLA. OFF. OF ST. TREASU	Revenue Fund	VO808834	1,750,000.00	BIWEEKLY PR:6/30/24-7/13/24;97825B0100	MG4JECH	REV00016043	7/16/2024	1,750,000.00
		Check REV00016043:	1,750,000.00					
STATE OF OKLA. OFF. OF ST. TREASU	Revenue Fund	VO810052	1,800,000.00	BIWEEKLY PR:7/14/24-7/27/24;97825B0200	MG4JECH	REV00016084	7/30/2024	1,800,000.00
		Check REV00016084:	1,800,000.00					
		<b>Total for STATE OF OKLA. OFF. OF ST. TREASURER:</b>	<b>3,550,000.00</b>					
STEFFENSON INSURANCE	Revenue Fund	VO808346	22.50	FEE/ISSUANCE 9 PIKEPASS 06/2024	APERINGO	RRV00349603	7/11/2024	22.50
		Check RRV00349603:	22.50					
		<b>Total for STEFFENSON INSURANCE:</b>	<b>22.50</b>					
STILLWATER MILLING COMPANY - CI	Revenue Fund	VO807493	440.25	FENCING SUPPLIES	DCRAIG	RRV00349173	7/2/2024	440.25
		Check RRV00349173:	440.25					
STILLWATER MILLING COMPANY - CI	Revenue Fund	VO808721	140.17	FENCING SUPPLIES	DCRAIG	RRV00349797	7/17/2024	140.17
		Check RRV00349797:	140.17					
		<b>Total for STILLWATER MILLING COMPANY - CLAREMORE:</b>	<b>580.42</b>					
STILLWATER MILLING COMPANY - D,	Revenue Fund	VO809884	76.00	EQUIPMENT PARTS & SUPPLIES	CSTEVENS	RRV00350052	7/29/2024	76.00
		Check RRV00350052:	76.00					
		<b>Total for STILLWATER MILLING COMPANY - DAVIS:</b>	<b>76.00</b>					
STILLWATER MILLING COMPANY - SI	Revenue Fund	VO808724	809.90	INSECTICIDES & HERBICIDES	RROWEN	RRV00349799	7/17/2024	809.90
		Check RRV00349799:	809.90					
		<b>Total for STILLWATER MILLING COMPANY - STILLWATER:</b>	<b>809.90</b>					
STILLWATER TAG AGENCY LLC	Revenue Fund	VO808352	190.00	FEE/ISSUANCE 76 PIKEPASS 06/2024	APERINGO	RRV00349604	7/11/2024	190.00
		Check RRV00349604:	190.00					
		<b>Total for STILLWATER TAG AGENCY LLC:</b>	<b>190.00</b>					
STOP STICK LTD	General	VO807958	658.49	F150- STOP STICK KIT: 0034239-IN	JSMITH	GEN00021452	7/9/2024	13,410.29

Vendor Name	Fund Desc	Voucher NO.	Amt Applied	Description	Approver	Check No.	Date Paid	Amt Check
		VO807959	<u>12,751.80</u>	TAHOE- STOP STICK KIT: 0034237-IN	JSMITH			
		Check GEN00021452:	<u>13,410.29</u>					
		<b>Total for STOP STICK LTD:</b>	<b>13,410.29</b>					
STRATUS BUILDING SOLUTIONS-OKC Revenue Fund		VO808397	<u>2,808.00</u>	CUSTODIAL SERVICES-JUNE 2024	TJDILL	RRV00349628	7/11/2024	3,258.00
		VO808398	<u>450.00</u>	OTHER CONTRACTUAL SERVICES	TJDILL			
		Check RRV00349628:	<u>3,258.00</u>					
STRATUS BUILDING SOLUTIONS-OKC Revenue Fund		VO809304	<u>36.59</u>	CLEANING & JANITORIAL SUPPLIES	TGORE	RRV00349903	7/22/2024	706.96
		VO809306	<u>170.37</u>	JANITORIAL & OTHER SUPPLIES	TJDILL			
		VO809297	<u>500.00</u>	OTHER CONTRACTUAL SERVICES	TGORE			
		Check RRV00349903:	<u>706.96</u>					
		<b>Total for STRATUS BUILDING SOLUTIONS-OKC:</b>	<b>3,964.96</b>					
STROUD TAG AGENCY	Revenue Fund	VO808354	<u>77.50</u>	FEE/ISSUANCE 31 PIKEPASS 06/2024	APERINGO	RRV00349605	7/11/2024	77.50
		Check RRV00349605:	<u>77.50</u>					
		<b>Total for STROUD TAG AGENCY:</b>	<b>77.50</b>					
STROUD TRUE VALUE - 1053	Revenue Fund	VO808725	<u>11.99</u>	OTHER COMMODITIES & SUPPLIES	RDTAYLOR	RRV00349795	7/17/2024	107.45
		VO808727	<u>54.98</u>	SMALL TOOLS - HARDWARE	RDTAYLOR			
		VO808728	<u>40.48</u>	SMALL TOOLS & EQUIP	RDTAYLOR			
		Check RRV00349795:	<u>107.45</u>					
STROUD TRUE VALUE - 1053	Revenue Fund	VO809418	<u>38.99</u>	SMALL TOOLS & EQUIP	RDTAYLOR	RRV00349944	7/24/2024	355.66
		VO809420	<u>52.49</u>	OTHER MAINTENANCE;EQUIP PARTS & SUPPLIES	RDTAYLOR			
		VO809432	<u>264.18</u>	ASPHALT & CONCRETE	RDTAYLOR			
		Check RRV00349944:	<u>355.66</u>					
STROUD TRUE VALUE - 1053	Revenue Fund	VO809885	<u>21.99</u>	SMALL TOOLS & EQUIPMENT	RDTAYLOR	RRV00350050	7/29/2024	21.99
		Check RRV00350050:	<u>21.99</u>					
		<b>Total for STROUD TRUE VALUE - 1053:</b>	<b>485.10</b>					
STUART TAG OFFICE - AMY BREWER	Revenue Fund	VO808356	<u>20.00</u>	FEE/ISSUANCE 8 PIKEPASS 06/2024	APERINGO	RRV00349606	7/11/2024	20.00
		Check RRV00349606:	<u>20.00</u>					
		<b>Total for STUART TAG OFFICE - AMY BREWER #3221:</b>	<b>20.00</b>					
SULPHUR MUNICIPAL AUTHORITY	Revenue Fund	VO807437	<u>97.34</u>	WATER	BPATTERS	EFT018735	7/1/2024	97.34
		Check EFT018735:	<u>97.34</u>					
		<b>Total for SULPHUR MUNICIPAL AUTHORITY:</b>	<b>97.34</b>					
SUMMIT UTILITIES OKLAHOMA, INC	Revenue Fund	VO808011	<u>82.52</u>	ELECTRIC	BPATTERS	EFT018779	7/9/2024	82.52
		Check EFT018779:	<u>82.52</u>					
		<b>Total for SUMMIT UTILITIES OKLAHOMA, INC:</b>	<b>82.52</b>					
SUPERMERCADOS MORELOS - 621 N	Revenue Fund	VO808365	<u>7.50</u>	FEE/ISSUANCE 3 PIKEPASS 06/2024	APERINGO	RRV00349607	7/11/2024	7.50
		Check RRV00349607:	<u>7.50</u>					
		<b>Total for SUPERMERCADOS MORELOS - 621 N MOORE:</b>	<b>7.50</b>					
SUPERMERCADOS MORELOS - E 31 T	Revenue Fund	VO808370	<u>17.50</u>	FEE/ISSUANCE 7 PIKEPASS 06/2024	APERINGO	RRV00349612	7/11/2024	17.50
		Check RRV00349612:	<u>17.50</u>					
		<b>Total for SUPERMERCADOS MORELOS - E 31 TULSA:</b>	<b>17.50</b>					
SUPERMERCADOS MORELOS - N HAI	Revenue Fund	VO808371	<u>32.50</u>	FEE/ISSUANCE 13 PIKEPASS 06/2024	APERINGO	RRV00349613	7/11/2024	32.50
		Check RRV00349613:	<u>32.50</u>					

Vendor Name	Fund Desc	Voucher NO.	Amt Applied	Description	Approver	Check No.	Date Paid	Amt Check
<b>Total for SUPERMERCADOS MORELOS - N HARVARD TULSA:</b>			<b>32.50</b>					
SUPERMERCADOS MORELOS - N MA Revenue Fund		VO808361	15.00	FEE/ISSUANCE 6 PIKEPASS 06/2024	APERINGO	RRV00349615	7/11/2024	15.00
		Check RRV00349615:	15.00					
<b>Total for SUPERMERCADOS MORELOS - N MACARTHUR WA:</b>			<b>15.00</b>					
SUPERMERCADOS MORELOS - NW 2 Revenue Fund		VO808366	20.00	FEE/ISSUANCE 8 PIKEPASS 06/2024	APERINGO	RRV00349611	7/11/2024	20.00
		Check RRV00349611:	20.00					
<b>Total for SUPERMERCADOS MORELOS - NW 23 OKC:</b>			<b>20.00</b>					
SUPERMERCADOS MORELOS - NW 5 Revenue Fund		VO808367	2.50	FEE/ISSUANCE 1 PIKEPASS 06/2024	APERINGO	RRV00349610	7/11/2024	2.50
		Check RRV00349610:	2.50					
<b>Total for SUPERMERCADOS MORELOS - NW 50 OKC:</b>			<b>2.50</b>					
SUPERMERCADOS MORELOS - S GAF Revenue Fund		VO808369	22.50	FEE/ISSUANCE 9 PIKEPASS 06/2024	APERINGO	RRV00349614	7/11/2024	22.50
		Check RRV00349614:	22.50					
<b>Total for SUPERMERCADOS MORELOS - S GARNETT TULSA:</b>			<b>22.50</b>					
SUPERMERCADOS MORELOS - S PEO Revenue Fund		VO808372	30.00	FEE/ISSUANCE 12 PIKEPASS 06/2024	APERINGO	RRV00349616	7/11/2024	30.00
		Check RRV00349616:	30.00					
<b>Total for SUPERMERCADOS MORELOS - S PEORIA TULSA:</b>			<b>30.00</b>					
SUPERMERCADOS MORELOS - SE 59 Revenue Fund		VO808368	20.00	FEE/ISSUANCE 8 PIKEPASS 06/2024	APERINGO	RRV00349608	7/11/2024	20.00
		Check RRV00349608:	20.00					
<b>Total for SUPERMERCADOS MORELOS - SE 59 OKC:</b>			<b>20.00</b>					
SUPERMERCADOS MORELOS - W HC Revenue Fund		VO808359	17.50	FEE/ISSUANCE 7 PIKEPASS 06/2024	APERINGO	RRV00349609	7/11/2024	17.50
		Check RRV00349609:	17.50					
<b>Total for SUPERMERCADOS MORELOS - W HOUSTON BA:</b>			<b>17.50</b>					
SWADLEY'S BAR-B-Q	Revenue Fund	VO809536	75.94	BUSINESS EXPENSES	PGOGGIN	RRV00349985	7/25/2024	75.94
		Check RRV00349985:	75.94					
<b>Total for SWADLEY'S BAR-B-Q:</b>			<b>75.94</b>					
SYNERGY DATACOM SUPPLY INC.	Revenue Fund	VO807495	658.42	OFFICES SUPPLIES - DATA PROCESSING SUP	MLOEFFEL	RRV00349174	7/2/2024	658.42
		Check RRV00349174:	658.42					
SYNERGY DATACOM SUPPLY INC.	Revenue Fund	VO809618	96.81	SMALL TOOLS;OTHER COMM;OFFICE SUPPLIES	MLOEFFEL	RRV00350015	7/26/2024	2,929.63
		VO809636	139.23	DATA PROCESSING;OTHER COMMODITIES	MLOEFFEL			
		VO809595	1,556.90	OTHER COMMODITIES;DATA PROCESSING	MLOEFFEL			
		VO809604	772.25	OFFICE SUPPLIES;DATA PROCESSING	MLOEFFEL			
		VO809620	335.83	DATA PROCESSING	MLOEFFEL			
		VO809625	28.61	EQUIPMENT PARTS & SUPPLIES	MLOEFFEL			
		Check RRV00350015:	2,929.63					
<b>Total for SYNERGY DATACOM SUPPLY INC.:</b>			<b>3,588.05</b>					
T & C ASPHALT MATERIALS LLC	Revenue Fund	VO807517	650.00	ASPHALT & CONCRETE SUPPLIES	RDTAYLOR	RRV00349175	7/2/2024	1,300.00
		VO807512	650.00	ASPHALT & CONCRETE SUPPLIES	RDTAYLOR			
		Check RRV00349175:	1,300.00					
<b>Total for T &amp; C ASPHALT MATERIALS LLC:</b>			<b>1,300.00</b>					
T & G CONSTRUCTION	Revenue Fund	VO808746	373.86	ASPHALT & CONCRETE	KWALLIS	RRV00349801	7/17/2024	373.86
		Check RRV00349801:	373.86					
<b>Total for T &amp; G CONSTRUCTION:</b>			<b>373.86</b>					



Vendor Name	Fund Desc	Voucher NO.	Amt Applied	Description	Approver	Check No.	Date Paid	Amt Check
T & W TIRE	Revenue Fund	VO807502 Check RRV00349283:	<u>651.60</u> 651.60	EQUIPMENT PARTS AND SUPPLIES	DCRAIG	RRV00349283	7/5/2024	651.60
T & W TIRE	Revenue Fund	VO807651 Check RRV00349291:	<u>392.20</u> 392.20	CORRECTED-EQUIPMENT PARTS AND SUPPLIES	JJENKINS	RRV00349291	7/5/2024	392.20
T & W TIRE	Revenue Fund	VO809383 Check RRV00349924:	<u>328.75</u> 328.75	EQUIPMENT PARTS; LABOR	DCRAIG	RRV00349924	7/24/2024	328.75
T & W TIRE	Revenue Fund	VO809440 VO809463 Check RRV00349947:	<u>120.16</u> <u>295.00</u> 415.16	EQUIPMENT REPAIRS EQUIPMENT REPAIRS	BWESTER DCRAIG	RRV00349947	7/24/2024	415.16
T & W TIRE	Revenue Fund	VO810080 VO810081 VO810079 Check RRV00350104:	<u>25.00</u> <u>276.85</u> <u>188.70</u> 490.55	EQUIPMENT REPAIR VEHICLE PARTS; EQUIP REPAIR EQUIPMENT PARTS AND SUPPLIES	BWESTER BWESTER DCRAIG	RRV00350104	7/31/2024	490.55
		<b>Total for T &amp; W TIRE:</b>	<b>2,278.26</b>					
T-N-C CLEANING - 9924	Revenue Fund	VO808399 Check RRV00349629:	<u>750.00</u> 750.00	CUSTODIAL SERVICES-JULY 2024	JSMITH	RRV00349629	7/11/2024	750.00
		<b>Total for T-N-C CLEANING - 9924:</b>	<b>750.00</b>					
T. H. ROGERS LUMBER CO	Revenue Fund	VO807503 VO807509 Check RRV00349179:	<u>266.30</u> <u>3.98</u> 270.28	FENCING SUPPLIES - HARDWARE HARDWARE	DCRAIG DCRAIG	RRV00349179	7/2/2024	270.28
T. H. ROGERS LUMBER CO	Revenue Fund	VO809467 Check RRV00349946:	<u>22.99</u> 22.99	SMALL TOOL & EQUIP	KWALLIS	RRV00349946	7/24/2024	22.99
		<b>Total for T. H. ROGERS LUMBER CO:</b>	<b>293.27</b>					
T. H. ROGERS LUMBER COMPANY	Revenue Fund	VO808753 Check RRV00349802:	<u>31.99</u> 31.99	HARDWARE	CSTEVENSON	RRV00349802	7/17/2024	31.99
		<b>Total for T. H. ROGERS LUMBER COMPANY:</b>	<b>31.99</b>					
TAG AGENCY OF ENID, INC	Revenue Fund	VO808481 Check RRV00349642:	<u>175.00</u> 175.00	FEE/ISSUANCE 70 PIKEPASS 06/2024	APERINGO	RRV00349642	7/11/2024	175.00
		<b>Total for TAG AGENCY OF ENID, INC:</b>	<b>175.00</b>					
TAGS 2 GO	Revenue Fund	VO808415 Check RRV00349640:	<u>30.00</u> 30.00	FEE/ISSUANCE 12 PIKEPASS 06/2024	APERINGO	RRV00349640	7/11/2024	30.00
		<b>Total for TAGS 2 GO:</b>	<b>30.00</b>					
TAYLOR SEPTIC TANK CLEANING	Revenue Fund	VO807522 Check RRV00349176:	<u>75.00</u> 75.00	EQUIPMENT RENTAL	RDTAYLOR	RRV00349176	7/2/2024	75.00
TAYLOR SEPTIC TANK CLEANING	Revenue Fund	VO809473 Check RRV00349945:	<u>75.00</u> 75.00	OTHER CONTRACTUAL;EQUIP RENTAL	RDTAYLOR	RRV00349945	7/24/2024	75.00
		<b>Total for TAYLOR SEPTIC TANK CLEANING:</b>	<b>150.00</b>					
TDS TELECOM - 94510	Revenue Fund	VO807436 Check EFT018730:	<u>242.99</u> 242.99	PHONE SERVICE	JLYTLE	EFT018730	7/1/2024	242.99
		<b>Total for TDS TELECOM - 94510:</b>	<b>242.99</b>					

Vendor Name	Fund Desc	Voucher NO.	Amt Applied	Description	Approver	Check No.	Date Paid	Amt Check
TEAL, GLYNDA	Revenue Fund	VO808826	<u>191.62</u>	JULY 2024 EXPENSES	KINMAN	RRV00349741	7/16/2024	191.62
		Check RRV00349741:	<u>191.62</u>					
		<b>Total for TEAL, GLYNDA:</b>	<b>191.62</b>					
TECH - LOCK	Revenue Fund	VO807531	<u>238.00</u>	BUILDING MAINTENANCE	JEHELLE	RRV00349177	7/2/2024	238.00
		Check RRV00349177:	<u>238.00</u>					
TECH - LOCK	Revenue Fund	VO809307	<u>95.00</u>	OTHER CONTRACTUAL SERVICES	TGOORE	RRV00349904	7/22/2024	95.00
		Check RRV00349904:	<u>95.00</u>					
		<b>Total for TECH - LOCK:</b>	<b>333.00</b>					
TECHSMITH	Revenue Fund	VO808748	<u>568.75</u>	ANNUAL SOFTWARE RENEWAL & SUBSCRIPTION	MLOEFFEL	RRV00349800	7/17/2024	568.75
		Check RRV00349800:	<u>568.75</u>					
		<b>Total for TECHSMITH:</b>	<b>568.75</b>					
TEIM DESIGN, PLLC	Capital Projects	VO809672	122,394.00	EWC-28803B: M2 RDWY DSGN: 12744	TJDILL	23A0000240	7/26/2024	446,936.81
		VO809670	30,634.50	EWC-28503A: M2 RDWY DSGN: 12741				
		VO809671	194,109.16	EWC-28603A: M2 RDWY DSGN: 12742				
		VO809673	36,913.60	EWC-28403B: M2 RDWY DSGN: 12740				
		VO809674	62,885.55	EWC-28303A: M2 RDWY DSGN: 12739				
		Check 23A0000240:	<u>446,936.81</u>					
<b>Total for TEIM DESIGN, PLLC:</b>	<b>446,936.81</b>							
TELCO SUPPLY COMPANY	General	VO809049	<u>180,217.36</u>	IN-MC-66: FIBER INSTALL: INV-20876	TJDILL	GEN00021501	7/19/2024	180,217.36
		Check GEN00021501:	<u>180,217.36</u>					
TELCO SUPPLY COMPANY	General	VO809873	38,594.95	SP-63B: FIBER CONDUIT INSTALL: INV-20914	TJDILL	GEN00021529	7/26/2024	116,909.80
		VO809878	78,314.85	SP-63B: FIBER CONDUIT INSTALL: INV-20941				
		Check GEN00021529:	<u>116,909.80</u>					
TELCO SUPPLY COMPANY	General	VO809912	<u>48,674.87</u>	IN-MC-66: FIBER INSTALL: INV-20886	TJDILL	GEN00021533	7/29/2024	48,674.87
		Check GEN00021533:	<u>48,674.87</u>					
TELCO SUPPLY COMPANY	Revenue Fund	VO808676	<u>3,916.87</u>	OTHER CONTRACTUAL - DATA PROCESSING	MLOEFFEL	RRV00349724	7/15/2024	3,916.87
		Check RRV00349724:	<u>3,916.87</u>					
		<b>Total for TELCO SUPPLY COMPANY:</b>	<b>349,718.90</b>					
TERRY ENTERPRISES	Revenue Fund	VO808640	<u>85,969.50</u>	MOWING SVCS, IN-M-23 ; 062024	JEHELLE	REV00016034	7/13/2024	85,969.50
		Check REV00016034:	<u>85,969.50</u>					
TERRY ENTERPRISES	Revenue Fund	VO809046	<u>54,750.75</u>	MOWING SVCS, IN-M-23 ; 070124	JEHELLE	REV00016054	7/18/2024	54,750.75
		Check REV00016054:	<u>54,750.75</u>					
		<b>Total for TERRY ENTERPRISES:</b>	<b>140,720.25</b>					
TETRA TECH FHC	General	VO808974	<u>43,325.80</u>	SP-63B: WR AET CVRSN: SR CON/TST 5226660	TJDILL	GEN00021491	7/17/2024	43,325.80
		Check GEN00021491:	<u>43,325.80</u>					
TETRA TECH FHC	General	VO809925	<u>6,000.00</u>	WR-MC-144: ADVRTSMNT/BIDDNG: 52274650	DBUTLER	GEN00021535	7/29/2024	6,000.00
		Check GEN00021535:	<u>6,000.00</u>					
		<b>Total for TETRA TECH FHC:</b>	<b>49,325.80</b>					
THE CARPET STORE	Revenue Fund	VO809309	250.00	OTHER CONTRACTUAL SERVICES	TGOORE	RRV00349942	7/24/2024	325.00
		VO809419	75.00	OTHER CONTRACTUAL SERVICES				

Vendor Name	Fund Desc	Voucher NO.	Amt Applied	Description	Approver	Check No.	Date Paid	Amt Check
		Check RRV00349942:	325.00					
		<b>Total for THE CARPET STORE:</b>	<b>325.00</b>					
THE RIVER'S EDGE COUNTERTOPS IN	Capital Projects	VO810125	806,730.69	EWC-28801A: TENANT MOVE COST:AA-007	TJD4JECH	23A0000251	7/31/2024	806,730.69
		Check 23A0000251:	806,730.69					
		<b>Total for THE RIVER'S EDGE COUNTERTOPS INC:</b>	<b>806,730.69</b>					
THE TAG AGENCY OF CACHE	Revenue Fund	VO808418	62.50	FEE/ISSUANCE 25 PIKEPASS 06/2024	APERINGO	RRV00349761	7/16/2024	62.50
		Check RRV00349761:	62.50					
		<b>Total for THE TAG AGENCY OF CACHE:</b>	<b>62.50</b>					
THE TAG AGENCY OF LINDSAY	Revenue Fund	VO808427	42.50	FEE/ISSUANCE 17 PIKEPASS 06/2024	APERINGO	RRV00349639	7/11/2024	42.50
		Check RRV00349639:	42.50					
		<b>Total for THE TAG AGENCY OF LINDSAY:</b>	<b>42.50</b>					
TIGER TAG AGENCY, LLC	Revenue Fund	VO808430	15.00	FEE/ISSUANCE 6 PIKEPASS 06/2024	APERINGO	RRV00349643	7/11/2024	15.00
		Check RRV00349643:	15.00					
		<b>Total for TIGER TAG AGENCY, LLC:</b>	<b>15.00</b>					
TINKER TAG AGENCY	Revenue Fund	VO808432	45.00	FEE/ISSUANCE 18 PIKEPASS 06/2024	APERINGO	RRV00349644	7/11/2024	45.00
		Check RRV00349644:	45.00					
		<b>Total for TINKER TAG AGENCY:</b>	<b>45.00</b>					
TISHOMINGO TAG AGENCY	Revenue Fund	VO808433	12.50	FEE/ISSUANCE 5 PIKEPASS 06/2024	APERINGO	RRV00349645	7/11/2024	12.50
		Check RRV00349645:	12.50					
		<b>Total for TISHOMINGO TAG AGENCY:</b>	<b>12.50</b>					
TITSWORTH, JOHN	Revenue Fund	VO808833	174.20	JULY 2024 EXPENSES	JPORTER	RRV00349744	7/16/2024	174.20
		Check RRV00349744:	174.20					
		<b>Total for TITSWORTH, JOHN:</b>	<b>174.20</b>					
TOWN WEST TAG AGENCY	Revenue Fund	VO808434	777.50	FEE/ISSUANCE 311 PIKEPASS 06/2024	APERINGO	RRV00349646	7/11/2024	777.50
		Check RRV00349646:	777.50					
		<b>Total for TOWN WEST TAG AGENCY:</b>	<b>777.50</b>					
TRAFFIC & LIGHTING SYSTEMS, LLC	General	VO807706	14,496.75	RDWY LGHT RPAIR/MATRL: CREEK: 224505.02	JSMITH	GEN00021449	7/3/2024	14,496.75
		Check GEN00021449:	14,496.75					
TRAFFIC & LIGHTING SYSTEMS, LLC	General	VO810046	11,777.07	RDWY LGHT RPAIR/MATRL: IND TP: 224507.02	JSMITH	GEN00021538	7/30/2024	11,777.07
		Check GEN00021538:	11,777.07					
		<b>Total for TRAFFIC &amp; LIGHTING SYSTEMS, LLC:</b>	<b>26,273.82</b>					
TRAFFIX DEVICES, INC.	Revenue Fund	VO807537	193.55	EQUIPMENT PARTS AND SUPPLIES	KWALLIS	RRV00349180	7/2/2024	193.55
		Check RRV00349180:	193.55					
		<b>Total for TRAFFIX DEVICES, INC.:</b>	<b>193.55</b>					
TRAILER WORLD OF TULSA	Revenue Fund	VO808755	4,250.00	MOBILE EQUIPMENT AND VEHICLES	MCOLLINS	RRV00349803	7/17/2024	4,250.00
		Check RRV00349803:	4,250.00					
		<b>Total for TRAILER WORLD OF TULSA:</b>	<b>4,250.00</b>					
TRANSCORE - 933493	General	VO808532	28,840.10	OTHER PROF SVCS, SFTWR ESCROW;24-01205	DMA4TGAT	GEN00021474	7/12/2024	298,840.10
		VO808533	270,000.00	INFINITY TOLL EQUIPMENT ; 24-01640	DMA4TGAT			
		Check GEN00021474:	298,840.10					

Vendor Name	Fund Desc	Voucher NO.	Amt Applied	Description	Approver	Check No.	Date Paid	Amt Check
TRANSCORE - 933493	General	VO809251	3,128,864.04	INSTALL INFNTY-TURNER TP: INV# 24-01735	JP4JECH	GEN00021505	7/22/2024	3,128,864.04
		Check GEN00021505:	3,128,864.04					
TRANSCORE - 933493	Revenue Fund	VO808642	27,121.74	EQUIPMENT REPLCMNT-FSR ; 24-01523	ABOULDEN	REV00016035	7/13/2024	50,011.44
		VO808643	22,889.70	PARTS USAGE, MAY 2024 ; 24-01539				
		Check REV00016035:	50,011.44					
TRANSCORE - 933493	Revenue Fund	VO809277	641,661.47	MNTHLY MAINT FEE, JUNE 2024 ; 24-01739	JP4JECH	REV00016065	7/22/2024	641,661.47
		Check REV00016065:	641,661.47					
TRANSCORE - 933493	Revenue Fund	VO810032	59,741.52	PARTS USAGE, JUNE 2024 ; 24-01820	ABOULDEN	REV00016083	7/29/2024	59,741.52
		Check REV00016083:	59,741.52					
TRANSCORE - 933493	Revenue Fund	VO808528	5,869.90	EQUIPMENT REPLACEMENT	ABOULDEN	RRV00349722	7/12/2024	5,869.90
		Check RRV00349722:	5,869.90					
		<b>Total for TRANSCORE - 933493:</b>	<b>4,184,988.47</b>					
TRI CITY TAG AGENCY	Revenue Fund	VO808436	57.50	FEE/ISSUANCE 23 PIKEPASS 06/2024	APERINGO	RRV00349647	7/11/2024	57.50
		Check RRV00349647:	57.50					
		<b>Total for TRI CITY TAG AGENCY:</b>	<b>57.50</b>					
TULSA ASPHALT LLC	Revenue Fund	VO807542	2,498.74	ASHPHALT & CONCRETE SUPPLIES	MKALKA	RRV00349182	7/2/2024	2,498.74
		Check RRV00349182:	2,498.74					
TULSA ASPHALT LLC	Revenue Fund	VO810083	4,265.31	ASHPHALT & CONCRETE SUPPLIES	MCCOLLINS	RRV00350102	7/31/2024	4,265.31
		Check RRV00350102:	4,265.31					
		<b>Total for TULSA ASPHALT LLC:</b>	<b>6,764.05</b>					
TULSA RV	Revenue Fund	VO808437	35.00	FEE/ISSUANCE 14 PIKEPASS 06/2024	APERINGO	RRV00349638	7/11/2024	35.00
		Check RRV00349638:	35.00					
		<b>Total for TULSA RV:</b>	<b>35.00</b>					
TURLEY TAG AGENCY - DELPHIA STO	Revenue Fund	VO808439	7.50	FEE/ISSUANCE 3 PIKEPASS 06/2024	APERINGO	RRV00349648	7/11/2024	7.50
		Check RRV00349648:	7.50					
		<b>Total for TURLEY TAG AGENCY - DELPHIA STOLP:</b>	<b>7.50</b>					
TURN-KEY MOBILE, INC.	General	VO807952	1,943.00	OHP- F150- PRINTERS/ACC: INV-71736	JSMITH	GEN00021451	7/9/2024	23,843.00
		VO807954	21,900.00	OHP- TAHOE- PRINTERS/ACC: INV-71743				
		Check GEN00021451:	23,843.00					
		<b>Total for TURN-KEY MOBILE, INC.:</b>	<b>23,843.00</b>					
TUTTLE TAG AGENCY - 2618 RACHEL	Revenue Fund	VO808440	132.50	FEE/ISSUANCE 53 PIKEASS 06/2024	APERINGO	RRV00349649	7/11/2024	132.50
		Check RRV00349649:	132.50					
		<b>Total for TUTTLE TAG AGENCY - 2618 RACHEL REDBURN:</b>	<b>132.50</b>					
TWIN CITIES READY MIX, INC.	Revenue Fund	VO807360	1,077.00	ASHPHALT & CONCRETE SUPPLIES	MCCOLLINS	RRV00349282	7/5/2024	5,385.00
		VO807362	3,590.00	ASHPHALT & CONCRETE SUPPLIES				
		VO807364	718.00	ASHPHALT & CONCRETE SUPPLIES				
		Check RRV00349282:	5,385.00					
TWIN CITIES READY MIX, INC.	Revenue Fund	VO808448	3,590.00	ASHPHALT & CONCRETE SUPPLIES	MCCOLLINS	RRV00349637	7/11/2024	3,590.00
		Check RRV00349637:	3,590.00					
TWIN CITIES READY MIX, INC.	Revenue Fund	VO808761	718.00	ASHPHALT & CONCRETE	BELLIS	RRV00349804	7/17/2024	718.00

Vendor Name	Fund Desc	Voucher NO.	Amt Applied	Description	Approver	Check No.	Date Paid	Amt Check
		Check RRV00349804:	718.00					
TWIN CITIES READY MIX, INC.	Revenue Fund	VO810084	5,205.50	ASPHALT & CONCRETE SUPPLIES	MCOLLINS	RRV00350103	7/31/2024	6,045.50
		VO810085	840.00	ASPHALT & CONCRETE SUPPLIES	BCANTREL			
		Check RRV00350103:	6,045.50					
		<b>Total for TWIN CITIES READY MIX, INC.:</b>	<b>15,738.50</b>					
UNICARE BUILDING MAINTENANCE I	Revenue Fund	VO809390	275.00	CUSTODIAL SERVICES	DCRAIG	RRV00349925	7/24/2024	275.00
		Check RRV00349925:	275.00					
		<b>Total for UNICARE BUILDING MAINTENANCE INC.:</b>	<b>275.00</b>					
UNITED LABORATORIES, INC.	Revenue Fund	VO810086	508.19	CLEANING SUPPLIES	RROWEN	RRV00350105	7/31/2024	508.19
		Check RRV00350105:	508.19					
		<b>Total for UNITED LABORATORIES, INC.:</b>	<b>508.19</b>					
UNITED RENTALS (NORTH AMERICA)	Revenue Fund	VO807543	435.00	EQUIPMENT RENTAL	KWALLIS	RRV00349184	7/2/2024	2,556.75
		VO807569	2,121.75	EQUIPMENT RENTAL	MCOLLINS			
		Check RRV00349184:	2,556.75					
UNITED RENTALS (NORTH AMERICA)	Revenue Fund	VO808401	3,508.00	EQUIPMENT RENTAL	SALLEN	RRV00349631	7/11/2024	3,508.00
		Check RRV00349631:	3,508.00					
UNITED RENTALS (NORTH AMERICA)	Revenue Fund	VO810087	2,121.75	EQUIPMENT RENTAL	MCOLLINS	RRV00350106	7/31/2024	2,121.75
		Check RRV00350106:	2,121.75					
		<b>Total for UNITED RENTALS (NORTH AMERICA):</b>	<b>8,186.50</b>					
UNITED STATES POSTAL SERVICE (PB	Revenue Fund	VO809928	500.00	POSTAGE-NEOPOST POSTAGE ON CALL	AHEITZ	RRV00350090	7/29/2024	500.00
		Check RRV00350090:	500.00					
		<b>Total for UNITED STATES POSTAL SERVICE (PBP):</b>	<b>500.00</b>					
UNLIMITED SWEEPERS AND CLEANERS	Revenue Fund	VO808956	59,493.00	SWEEPING SVCS, SP-SW-24 ; 1159	TJD4JECH	REV00016045	7/17/2024	180,730.70
		VO808955	40,591.10	SWEEPING SVCS, SP-SW-24 ; 1158	TJD4JECH			
		VO808957	50,904.00	SWEEPING SVCS, SP-SW-24 ; 1160	TJD4JECH			
		VO808958	29,742.60	SWEEPING SVCS, SP-SW-24 ; 1162	TJD4JECH			
		Check REV00016045:	180,730.70					
		<b>Total for UNLIMITED SWEEPERS AND CLEANERS:</b>	<b>180,730.70</b>					
VALLEY BODY SHOP INC.	Revenue Fund	VO808441	27.50	FEE/ISSUANCE 11 PIKEPASS 06/2024	APERINGO	RRV00349650	7/11/2024	27.50
		Check RRV00349650:	27.50					
		<b>Total for VALLEY BODY SHOP INC.:</b>	<b>27.50</b>					
VANCE MOTORS	Revenue Fund	VO808712	631.72	VEHICLE PARTS AND SUPPLIES	RROWEN	RRV00349853	7/18/2024	631.72
		Check RRV00349853:	631.72					
VANCE MOTORS	Revenue Fund	VO809299	732.00	VEHICLE PARTS AND SUPPLIES	CSTEVENS	RRV00349984	7/25/2024	732.00
		Check RRV00349984:	732.00					
		<b>Total for VANCE MOTORS:</b>	<b>1,363.72</b>					
VELMA TAG AGENCY - 6917	Revenue Fund	VO808451	5.00	FEE/ISSUANCE 2 PIKEPASS 06/2024	APERINGO	RRV00349651	7/11/2024	5.00
		Check RRV00349651:	5.00					
		<b>Total for VELMA TAG AGENCY - 6917:</b>	<b>5.00</b>					
VERDIGRIS VALLEY ELECTRIC COOP, I	Revenue Fund	VO808374	384.66	ELECTRIC	BPATTERS	EFT018793	7/11/2024	384.66
		Check EFT018793:	384.66					

Vendor Name	Fund Desc	Voucher NO.	Amt Applied	Description	Approver	Check No.	Date Paid	Amt Check
<b>Total for VERDIGRIS VALLEY ELECTRIC COOP, INC.:</b>			<b>384.66</b>					
VERIZON WIRELESS SERVICES LLC	Revenue Fund	VO808655	3,640.44	PHONE 442175559-00001	JLYTLE	EFT018799	7/15/2024	3,640.44
		Check EFT018799:	3,640.44					
<b>Total for VERIZON WIRELESS SERVICES LLC:</b>			<b>3,640.44</b>					
VERMEER GREAT PLAINS, INC.	Revenue Fund	VO808780	9.42	EQUIPMENT PARTS & SUPPLIES	PGOGGIN	RRV00349805	7/17/2024	9.42
		Check RRV00349805:	9.42					
<b>Total for VERMEER GREAT PLAINS, INC.:</b>			<b>9.42</b>					
VICARS POWERSPORTS	Revenue Fund	VO808452	45.00	FEE/ISSUANCE 18 PIKEPASS 06/2024	APERINGO	RRV00349652	7/11/2024	45.00
		Check RRV00349652:	45.00					
<b>Total for VICARS POWERSPORTS:</b>			<b>45.00</b>					
VILLAGE TAG AGENCY	Revenue Fund	VO808453	257.50	FEE/ISSUANCE 103 PIKEPASS 06/2024	APERINGO	RRV00349653	7/11/2024	257.50
		Check RRV00349653:	257.50					
<b>Total for VILLAGE TAG AGENCY:</b>			<b>257.50</b>					
VINITA TAG OFFICE- #1808 DEBORAH	Revenue Fund	VO808442	167.50	FEE/ISSUANCE 67 PIKEPASS 06/2024	APERINGO	RRV00349654	7/11/2024	167.50
		Check RRV00349654:	167.50					
<b>Total for VINITA TAG OFFICE- #1808 DEBORAH PATE:</b>			<b>167.50</b>					
VINITA UTILITIES AUTHORITY	Revenue Fund	VO807711	3,591.69	WATER	BPATTERS	EFT018760	7/5/2024	3,591.69
		Check EFT018760:	3,591.69					
<b>Total for VINITA UTILITIES AUTHORITY:</b>			<b>3,591.69</b>					
VINNY B'S LOCK AND KEY LLC	Revenue Fund	VO809886	230.00	BUILDING MAINTENANCE SUPPLIES	DCRAIG	RRV00350042	7/26/2024	230.00
		Check RRV00350042:	230.00					
<b>Total for VINNY B'S LOCK AND KEY LLC:</b>			<b>230.00</b>					
W.E. ALLFORD PROPANE	Revenue Fund	VO809481	699.30	NATURAL & PROPANE GAS	KDERVIN	RRV00349948	7/24/2024	699.30
		Check RRV00349948:	699.30					
<b>Total for W.E. ALLFORD PROPANE:</b>			<b>699.30</b>					
W2M CONSULTING, LLC	General	VO808975	3,600.00	IN-MC-73: FNL PLANS: M202-12	DBUTLER	GEN00021490	7/17/2024	3,600.00
		Check GEN00021490:	3,600.00					
<b>Total for W2M CONSULTING, LLC:</b>			<b>3,600.00</b>					
WANCO, INC	Revenue Fund	VO807545	575.00	EQUIPMENT PARTS & SUPPLIES	KWALLIS	RRV00349186	7/2/2024	575.00
		Check RRV00349186:	575.00					
<b>Total for WANCO, INC:</b>			<b>575.00</b>					
WANCO, INC.	Revenue Fund	VO808791	1,360.00	EQUIPMENT PARTS - FREIGHT	SALLEN	RRV00349894	7/19/2024	1,360.00
		Check RRV00349894:	1,360.00					
<b>Total for WANCO, INC.:</b>			<b>1,360.00</b>					
WARNER TAG AGENCY -- KYLA PARK	Revenue Fund	VO808443	35.00	FEE/ISSUANCE 14 PIKEPASS 06/2024	APERINGO	RRV00349655	7/11/2024	35.00
		Check RRV00349655:	35.00					
<b>Total for WARNER TAG AGENCY -- KYLA PARKER #5118:</b>			<b>35.00</b>					
WARREN CAT	Revenue Fund	VO807546	259.47	EQUIPMENT SUPPLIES AND PARTS	CHUGHES	RRV00349380	7/8/2024	2,447.92
		VO807573	184.48	EQUIPMENT PARTS AND SUPPLIES	RDTAYLOR			
		VO807979	2,003.97	EQUIPMENT REPAIRS/PARTS AND SUPPLIES	MCOLLINS			
		Check RRV00349380:	2,447.92					

Vendor Name	Fund Desc	Voucher NO.	Amt Applied	Description	Approver	Check No.	Date Paid	Amt Check
WARREN CAT	Revenue Fund	VO808402	6.30	EQUIPMENT PARTS AND SUPPLIES	RDTAYLOR	RRV00349632	7/11/2024	4,112.20
		VO808405	105.08	EQUIPMENT PARTS AND SUPPLIES	DCRAIG			
		VO808407	42.70	EQUIPMENT PARTS AND SUPPLIES	DCRAIG			
		VO808403	3,911.84	EQUIPMENT PARTS AND SUPPLIES	MCOLLINS			
		VO808404	46.28	EQUIPMENT PARTS AND SUPPLIES	DCRAIG			
	Check RRV00349632:		4,112.20					
WARREN CAT	Revenue Fund	VO809135	615.42	EQUIPMENT RENTAL	PGOGGIN	RRV00349895	7/19/2024	1,072.39
		VO808801	456.97	EQUIPMENT PARTS AND SUPPLIES	RDTAYLOR			
		Check RRV00349895:	1,072.39					
WARREN CAT	Revenue Fund	VO809523	31.68	EQUIPMENT PARTS & SUPPLIES	JJENKINS	RRV00349986	7/25/2024	1,384.30
		VO809524	861.29	HARDWARE	RDTAYLOR			
		VO809516	80.90	EQUIPMENT PARTS & SUPPLIES	JJENKINS			
		VO809527	308.31	EQUIPMENT PARTS & SUPPLIES	CHUGHES			
		VO809513	102.12	EQUIP PARTS & SUPPLIES	JJENKINS			
	Check RRV00349986:		1,384.30					
WARREN CAT	Revenue Fund	VO810095	296.17	EQUIPMENT PARTS AND SUPPLIES	KWALLIS	RRV00350107	7/31/2024	9,139.74
		VO810107	288.41	VEHICLE PARTS AND SUPPLIES	KWALLIS			
		VO810109	2,775.91	EQUIPMENT PARTS; EQUIPMENT REPAIR	SALLEN			
		VO810088	12.85	VEHICLE PARTS AND SUPPLIES	RROWEN			
		VO810089	4.35	EQUIPMENT PARTS AND SUPPLIES	PGOGGIN			
		VO810106	21.00	EQUIPMENT PARTS AND SUPPLIES	RROWEN			
		VO810112	5,741.05	EQUIPMENT PARTS AND SUPPLIES	SALLEN			
	Check RRV00350107:		9,139.74					
	<b>Total for WARREN CAT:</b>		<b>18,156.55</b>					
WASTE CONNECTIONS OF TX	Revenue Fund	VO808411	270.71	SOLID WASTE DISPOSAL	TJDILL	RRV00349633	7/11/2024	302.36
		VO808428	31.65	SOLID WASTE DISPOSAL	KWALLIS			
		Check RRV00349633:	302.36					
	<b>Total for WASTE CONNECTIONS OF TX:</b>		<b>302.36</b>					
WATONGA TAG AGENCY - #0615	Revenue Fund	VO808444	37.50	FEE/ISSUANCE 15 PIKEPASS 06/2024	APERINGO	RRV00349658	7/11/2024	37.50
		Check RRV00349658:	37.50					
	<b>Total for WATONGA TAG AGENCY - #0615:</b>		<b>37.50</b>					
WATSON MOTORS	Revenue Fund	VO808446	2.50	FEE/ISSUANCE 1 PIKEPASS 06/2024	APERINGO	RRV00349657	7/11/2024	2.50
		Check RRV00349657:	2.50					
	<b>Total for WATSON MOTORS:</b>		<b>2.50</b>					
WAURIKA TAG AGENCY	Revenue Fund	VO808447	5.00	FEE/ISSUANCE 2 PIKAPASS 06/2024	APERINGO	RRV00349656	7/11/2024	5.00
		Check RRV00349656:	5.00					
	<b>Total for WAURIKA TAG AGENCY:</b>		<b>5.00</b>					
WEATHERFORD TAG OFFICE	Revenue Fund	VO808449	60.00	FEE/ISSUANCE 24 PIKEPASS 06/2024	APERINGO	RRV00349659	7/11/2024	60.00
		Check RRV00349659:	60.00					
	<b>Total for WEATHERFORD TAG OFFICE:</b>		<b>60.00</b>					
WEAVER TAG AGENCY	Revenue Fund	VO808450	42.50	FEE/ISSUANCE 17 PIKEPASS 06/2024	APERINGO	RRV00349660	7/11/2024	42.50
		Check RRV00349660:	42.50					
	<b>Total for WEAVER TAG AGENCY:</b>		<b>42.50</b>					

Vendor Name	Fund Desc	Voucher NO.	Amt Applied	Description	Approver	Check No.	Date Paid	Amt Check
WEBER, DANA S.	Revenue Fund	VO808818	135.34	JULY 2024 EXPENSES	JPORTER	RRV00349739	7/16/2024	135.34
		Check RRV00349739:	135.34					
		<b>Total for WEBER, DANA S.:</b>	<b>135.34</b>					
WELDON PARTS MCALESTER	Revenue Fund	VO807579	227.30	EQUIPMENT PARTS AND SUPPLIES	BWESTER	RRV00349285	7/5/2024	375.66
		VO807580	148.36	VEHICLE PARTS AND SUPPLIES				
		Check RRV00349285:	375.66					
WELDON PARTS MCALESTER	Revenue Fund	VO808803	18.03	SMALL TOOLS & EQUIPMENT	BELLIS	RRV00349809	7/17/2024	18.03
		Check RRV00349809:	18.03					
		<b>Total for WELDON PARTS MCALESTER:</b>	<b>761.78</b>					
WELDON PARTS MCALESTER	Revenue Fund	VO809528	368.09	VEHICLE PARTS & SUPPLIES	BWESTER	RRV00349987	7/25/2024	368.09
		Check RRV00349987:	368.09					
		<b>Total for WELDON PARTS MCALESTER:</b>	<b>761.78</b>					
WESTLAKE ACE HARDWARE, OUTER	Revenue Fund	VO809892	81.95	DRAINAGE & CULVERTS	JJENKINS	RRV00350065	7/29/2024	143.09
		VO809876	61.14	SMALL TOOLS & DRAINAGE/CULVERTS				
		Check RRV00350065:	143.09					
<b>Total for WESTLAKE ACE HARDWARE, OUTER BANKS ACE:</b>	<b>143.09</b>							
WESTLAKE TAG AGENCY- CHAD LAM	Revenue Fund	VO808454	232.50	FEE/ISSUANCE 93 PIKEPASS 06/2024	APERINGO	RRV00349661	7/11/2024	232.50
		Check RRV00349661:	232.50					
		<b>Total for WESTLAKE TAG AGENCY- CHAD LAMLE #8828:</b>	<b>232.50</b>					
WETUMKA TAG AGENCY - ANITA PA	Revenue Fund	VO808455	10.00	FEE/ISSUANCE 4 PIKEPASS 06/2024	APERINGO	RRV00349662	7/11/2024	10.00
		Check RRV00349662:	10.00					
		<b>Total for WETUMKA TAG AGENCY - ANITA PASLEY #3217:</b>	<b>10.00</b>					
WILLIAM'S FOOD	Revenue Fund	VO809016	171.41	EMPLOYEE INCENTIVE-FOOD/CATERING	PGOGGIN	RRV00349811	7/17/2024	171.41
		Check RRV00349811:	171.41					
		<b>Total for WILLIAM'S FOOD:</b>	<b>171.41</b>					
WILLIAM'S FOOD #7	Revenue Fund	VO807589	383.16	BOTTLED WATER -SAFETY & MEDICAL SUPPLIES	KWALLIS	RRV00349280	7/5/2024	383.16
		Check RRV00349280:	383.16					
		<b>Total for WILLIAM'S FOOD #7:</b>	<b>506.66</b>					
WILLIAM'S FOOD #7	Revenue Fund	VO808429	123.50	EMPLOYEE INCENTIVE AWARDS-FOOD	KWALLIS	RRV00349623	7/11/2024	123.50
		Check RRV00349623:	123.50					
		<b>Total for WILLIAM'S FOOD #7:</b>	<b>506.66</b>					
WILLIAMS DISCOUNT FOODS #10	Revenue Fund	VO807583	16.98	EMPLOYEE INCENTIVE AWARDS - FOOD, CATERI	RDTAYLOR	RRV00349189	7/2/2024	16.98
		Check RRV00349189:	16.98					
		<b>Total for WILLIAMS DISCOUNT FOODS #10:</b>	<b>333.51</b>					
WILLIAMS DISCOUNT FOODS #10	Revenue Fund	VO809020	316.53	EMPLOYEE INCENTIVE-FOOD/CATERING	RDTAYLOR	RRV00349810	7/17/2024	316.53
		Check RRV00349810:	316.53					
		<b>Total for WILLIAMS DISCOUNT FOODS #10:</b>	<b>333.51</b>					
WILLIAMS FOODS	Revenue Fund	VO808456	5.00	FEE/ISSUANCE 2 PIKEPASS 06/2024	APERINGO	RRV00349663	7/11/2024	5.00
		Check RRV00349663:	5.00					
		<b>Total for WILLIAMS DISCOUNT FOODS #10:</b>	<b>333.51</b>					
WILLIAMS FOODS	Revenue Fund	VO808458	35.00	FEE/ISSUANCE 14 PIKEPASS 06/2024	APERINGO	RRV00349664	7/11/2024	35.00
		Check RRV00349664:	35.00					
		<b>Total for WILLIAMS DISCOUNT FOODS #10:</b>	<b>333.51</b>					
WILLIAMS FOODS	Revenue Fund	VO808463	102.50	FEE/ISSUANCE 41 PIKEPASS 06/2024	APERINGO	RRV00349665	7/11/2024	102.50
		Check RRV00349665:	102.50					
		<b>Total for WILLIAMS DISCOUNT FOODS #10:</b>	<b>333.51</b>					



Vendor Name	Fund Desc	Voucher NO.	Amt Applied	Description	Approver	Check No.	Date Paid	Amt Check
WILLIAMS FOODS	Revenue Fund	VO808462	<u>5.00</u>	FEE/ISSUANCE 2 PIKEPASS 06/2024	APERINGO	RRV00349666	7/11/2024	5.00
		Check RRV00349666:	<u>5.00</u>					
WILLIAMS FOODS	Revenue Fund	VO808464	<u>2.50</u>	FEE/ISSUANCE 1 PIKEPASS 06/2024	APERINGO	RRV00349667	7/11/2024	2.50
		Check RRV00349667:	<u>2.50</u>					
WILLIAMS FOODS	Revenue Fund	VO808469	<u>25.00</u>	FEE/ISSUANCE 10 PIKEPASS 06/2024	APERINGO	RRV00349668	7/11/2024	25.00
		Check RRV00349668:	<u>25.00</u>					
WILLIAMS FOODS	Revenue Fund	VO808459	<u>2.50</u>	FEE/ISSUANCE 1 PIKEPASS 06/2024	APERINGO	RRV00349669	7/11/2024	2.50
		Check RRV00349669:	<u>2.50</u>					
WILLIAMS FOODS	Revenue Fund	VO808466	<u>115.00</u>	FEE/ISSUANCE 46 PIKEPASS 06/2024	APERINGO	RRV00349670	7/11/2024	115.00
		Check RRV00349670:	<u>115.00</u>					
WILLIAMS FOODS	Revenue Fund	VO808465	<u>32.50</u>	FEE/ISSUANCE 13 PIKEPASS 06/2024	APERINGO	RRV00349671	7/11/2024	32.50
		Check RRV00349671:	<u>32.50</u>					
WILLIAMS FOODS	Revenue Fund	VO808461	<u>10.00</u>	FEE/ISSUANCE 4 PIKEPASS 06/2024	APERINGO	RRV00349672	7/11/2024	10.00
		Check RRV00349672:	<u>10.00</u>					
WILLIAMS FOODS	Revenue Fund	VO808467	<u>10.00</u>	FEE/ISSUANCE 4 PIKEPASS 06/2024	APERINGO	RRV00349673	7/11/2024	10.00
		Check RRV00349673:	<u>10.00</u>					
		<b>Total for WILLIAMS FOODS:</b>	<b>345.00</b>					
WILLIAMS SCOTSMAN, INC.	Revenue Fund	VO808431	<u>714.38</u>	BUILDING RENTAL; LATE FEES	JMELTON	RRV00349635	7/11/2024	714.38
		Check RRV00349635:	<u>714.38</u>					
		<b>Total for WILLIAMS SCOTSMAN, INC.:</b>	<b>714.38</b>					
WINDSTREAM	Revenue Fund	VO808384	<u>819.16</u>	CABLE SERVICE	JLYTLE	EFT018794	7/11/2024	819.16
		Check EFT018794:	<u>819.16</u>					
		<b>Total for WINDSTREAM:</b>	<b>819.16</b>					
WINTER EQUIPMENT COMPANY, INC	Revenue Fund	VO808435	<u>656.60</u>	HARDWARE	JJENKINS	RRV00349634	7/11/2024	656.60
		Check RRV00349634:	<u>656.60</u>					
		<b>Total for WINTER EQUIPMENT COMPANY, INC.:</b>	<b>656.60</b>					
WOODCREST TAG AGENCY	Revenue Fund	VO808471	<u>122.50</u>	FEE/ISSUANCE 49 PIKEPASS 06/2024	APERINGO	RRV00349674	7/11/2024	122.50
		Check RRV00349674:	<u>122.50</u>					
		<b>Total for WOODCREST TAG AGENCY:</b>	<b>122.50</b>					
WOODWARD TAG AGENCY	Revenue Fund	VO808473	<u>45.00</u>	FEE/ISSUANCE 18 PIKEPASS 06/2024	APERINGO	RRV00349675	7/11/2024	45.00
		Check RRV00349675:	<u>45.00</u>					
		<b>Total for WOODWARD TAG AGENCY:</b>	<b>45.00</b>					
WYLIE SPRAYERS OF OKLAHOMA	Revenue Fund	VO810116	<u>168.00</u>	EQUIPMENT PARTS AND SUPPLIES	PGOGGIN	RRV00350109	7/31/2024	168.00
		Check RRV00350109:	<u>168.00</u>					
		<b>Total for WYLIE SPRAYERS OF OKLAHOMA:</b>	<b>168.00</b>					
WYNNEWOOD TAG AGENCY LLC	Revenue Fund	VO808475	<u>10.00</u>	FEE/ISSUANCE 4 PIKEPASS 06/2024	APERINGO	RRV00349676	7/11/2024	10.00
		Check RRV00349676:	<u>10.00</u>					
		<b>Total for WYNNEWOOD TAG AGENCY LLC:</b>	<b>10.00</b>					

Vendor Name	Fund Desc	Voucher NO.	Amt Applied	Description	Approver	Check No.	Date Paid	Amt Check
XCESSORIES SQUARED DEVELOPMENT	Revenue Fund	VO809024	5,126.50	SIGNING SUPPLIES	MCOLLINS	RRV00349812	7/17/2024	5,126.50
		Check RRV00349812:	5,126.50					
XCESSORIES SQUARED DEVELOPMENT	Revenue Fund	VO809529	1,245.29	SIGNING SUPPLIES	SALLEN	RRV00349988	7/25/2024	1,245.29
		Check RRV00349988:	1,245.29					
<b>Total for XCESSORIES SQUARED DEVELOPMENT &amp; MFG. IN:</b>			<b>6,371.79</b>					
YALE TAG AGENCY	Revenue Fund	VO808476	17.50	FEE/ISSUANCE 7 PIKEPASS 06/2024	APERINGO	RRV00349677	7/11/2024	17.50
		Check RRV00349677:	17.50					
<b>Total for YALE TAG AGENCY:</b>			<b>17.50</b>					
YOUNG'S TIRE	Revenue Fund	VO809531	290.86	EQUIPMENT PARTS & SUPPLIES	DCRAIG	RRV00349989	7/25/2024	304.36
		VO809530	13.50	EQUIPMENT REPAIRS				
		Check RRV00349989:	304.36					
YOUNG'S TIRE	Revenue Fund	VO809918	13.50	EQUIPMENT REPAIR	DCRAIG	RRV00350053	7/29/2024	45.50
		VO809921	32.00	EQUIPMENT REPAIR				
		Check RRV00350053:	45.50					
<b>Total for YOUNG'S TIRE:</b>			<b>349.86</b>					
YUKON TAG AGENCY - #0928	Revenue Fund	VO808478	217.50	FEE/ISSUANCE 87 PIKEPASS 06/2024	APERINGO	RRV00349679	7/11/2024	217.50
		Check RRV00349679:	217.50					
<b>Total for YUKON TAG AGENCY - #0928:</b>			<b>217.50</b>					
YUKON'S BEST TAG AGENCY, INC-09:	Revenue Fund	VO808479	120.00	FEE/ISSUANCE 48 PIKEPASS 06/2024	APERINGO	RRV00349678	7/11/2024	120.00
		Check RRV00349678:	120.00					
<b>Total for YUKON'S BEST TAG AGENCY, INC-0927:</b>			<b>120.00</b>					
ZACS TIRE AND RIM	Revenue Fund	VO808438	20.00	EQUIPMENT REPAIR	CSTEVENS	RRV00349636	7/11/2024	20.00
		Check RRV00349636:	20.00					
ZACS TIRE AND RIM	Revenue Fund	VO809026	310.00	EQUIPMENT PARTS & SUPPLIES	CSTEVENS	RRV00349813	7/17/2024	310.00
		Check RRV00349813:	310.00					
		<b>Total for ZACS TIRE AND RIM:</b>						
ZION SERVICES LLC	Revenue Fund	VO809310	2,285.00	BUILDING MAINTENANCE SERVICES	TGORE	RRV00349906	7/22/2024	2,285.00
		Check RRV00349906:	2,285.00					
<b>Total for ZION SERVICES LLC:</b>			<b>2,285.00</b>					
<b>REPORT TOTAL:</b>			<b>44,251,359.98</b>					

# GENERAL CONSULTING ENGINEER'S MONTHLY REPORT

Prepared for:



**OKLAHOMA**  
Turnpike Authority

September 10, 2024  
(Period Ending July 31, 2024)

# CONSULTING ENGINEER’S PROJECT STATUS REPORT

REPORT: September 23, 2024 (July 31, 2024)  
 FROM: Jimmy Sparks, P.E.  
 Consulting Engineer  
 TO: Joe Echelle, P.E. – OTA Executive Director  
 Oklahoma Turnpike Authority Members  
 SUBJECT: Monthly Status Report on the Capital Plan Projects and Trust Requirements

CAPITAL PLAN SUMMARY						
PROJECT YEAR	NUMBER OF PROJECTS	BUDGET	AWARDED TO DATE	PERCENT AWARDED TO DATE	EXPENDED TO DATE	PERCENT OF BUDGET EXPENDED TO DATE
2024 Capital Plan	13	\$105,656,539	\$66,205,635	63%	\$31,754,884	30%
<i>The 2024 Capital Plan includes bridge rehabilitation, roadway rehabilitation and reconstruction, maintenance facility improvements, toll plaza modernization projects, concession improvements, positive barrier, signing and striping, drainage improvements, ramp improvements, shoulder improvements, and guardrail repairs and construction.</i>						
2023 Capital Plan	27	\$102,135,148	\$120,368,241	118%	\$99,569,670	97%
<i>The 2023 Capital Plan includes bridge rehabilitation, roadway rehabilitation and reconstruction, maintenance facility improvements, toll plaza modernization projects, concession improvements, positive barrier, signing and striping, drainage improvements, ramp improvements, shoulder improvements, and guardrail repairs and construction.</i>						
2022 Capital Plan	21	\$113,068,100	\$73,411,788	65%	\$71,163,416	63%
<i>The 2022 Capital Plan includes bridge rehabilitation, roadway rehabilitation and reconstruction, maintenance facility improvements, toll plaza modernization projects, concession improvements, positive barrier, signing and striping, drainage improvements, ramp improvements, shoulder improvements, and guardrail repairs and construction.</i>						

## TRUST REQUIREMENTS

### INSPECTIONS

The status of the Consulting Engineer’s Annual Inspections through this report is detailed in the table below.

BRIDGES	CULVERTS	PAVEMENT	ARCHITECTURAL & ELECTRICAL
Chickasaw Cimarron Muskogee Turner	Cherokee Muskogee Will Rogers	Cimarron Chickasaw Creek H.E. Bailey Indian Nation John Kilpatrick Kickapoo Turner Will Rogers	Cherokee Cimarron Chickasaw Creek Gilcrease H.E. Bailey Indian Nation John Kilpatrick Kickapoo Muskogee Turner Will Rogers

The status of the Consulting Engineer’s Emergency and/or Special Inspections within this report period is detailed in the table below. The status of the Consulting Engineer’s Emergency and/or Special Inspections within this report period is detailed in the table below.

EMERGENCY/SPECIAL INSPECTIONS*
*Emergency Inspection - Turner Turnpike Bridge 78.80 – Vehicle Fire 08/01/24.

\*Detailed reports of emergency and/or special inspections are submitted to OTA Staff and are also included in the Consulting Engineer’s Monthly Reports.

**MEETING SERVICES**

The meetings attended by the Consulting Engineer are listed in the table below.

PROJECT	MEETING DESCRIPTION
MU-MC-53	99% Plan Review Meeting
SP-73	Preliminary Plan Review Meeting
John Kilpatrick Turnpike	Pavement Inspection
SP-63A	Turner AET Project Status Meeting
SP-63B	Will Rogers AET Project Status Meeting
Project Status Meeting	Discuss Current Projects
Agenda Meeting	Discuss Authority Meeting Agenda
Authority Meeting	Monthly Meeting

If you should have any questions or comments, please contact me at (405)242-6600.

Sincerely,



Jimmy Sparks, PE Consulting Engineer

## **ACCESS Oklahoma Program**

On February 22, 2022, Governor Kevin Stitt and Authority Executive Director/Oklahoma Secretary of Transportation Tim Gatz announced a new \$5 billion, 15-year turnpike improvement and expansion program known as “ACCESS Oklahoma: Advancing and Connecting Communities and Economies Safely Statewide” (“ACCESS Oklahoma”). The ACCESS Oklahoma program, to be undertaken in cooperation with ODOT, includes plans to make major investments in the turnpike system in the State to improve traffic safety, facilitate better movement of products and people, and provide new economic development opportunities in urban areas and rural Oklahoma.

ACCESS Oklahoma focuses on improving highway safety for motorists, increasing travel time reliability, easing congestion in metropolitan areas of the State, moving freight across the State and adding access to communities that previously were not connected to turnpikes. The new turnpike corridors in ACCESS Oklahoma will connect Oklahoma’s existing highway system maintained by the State and provide reliever routes for Oklahoma’s most congested highways, especially for commercial truck traffic.

Studies and preliminary design are underway for the projects currently expected to be included in the ACCESS Oklahoma program. These projects are expected to be financed from a portion of the proceeds of the Series 2023 Bonds and a number of additional issuances of Second Senior Bonds and potentially Junior Obligations over the next fifteen years.

Design, environmental, right-of way, and utility services are currently underway for several projects of the proposed projects. The ACCESS Oklahoma Program Manager is tracking these activities and coordinating with OTA and design consultants to develop project schedules.

## Inter-Office Memorandum

Date: August 6, 2024  
To: Jimmy Sparks, PE  
From: David K. Murdock, PE  
Subject: Turner Turnpike Bridge 78.8 (NBI 31858) – Special Bridge Inspection  
Project No.: 022-00374



On August 1, 2024, Olsson received a request from the OTA to look at westbound Bridge 78.8 on the Turner Turnpike. The bridge was subjected to the heat from a burning tractor trailer vehicle (photo 1). A representative from Olsson visited the bridge later that same day to perform an initial inspection. A second hands-on inspection was performed on August 5, 2024. During the second inspection, access to the superstructure was possible via a man lift. The bridge is a two-span simply supported bridge. The spans are each 140-feet long with four Type J prestressed beams in each span and metal stay-in-place deck forms (photo 2).

At the time of the initial inspection, clean up was under way and the bridge superstructure was still hot so, observations were made from the surface of the roadway and bridge deck. Following this initial inspection, it was decided to cone off the bridge deck to remove load from the east most (exterior) beam and to call for a hands-on inspection of the bridge. Photos taken at that time showed extensive spall damage to the top and bottom flanges of the exterior beam, outside face of the deck, and outside face of the parapet (photos 3 and 4). The driving surface of the bridge did not show signs of damage.

The second inspection was performed via a man-lift provided by the OTA. During the inspection it was noted that there was damage to three of the four beams in span 2 (northern most span). Damage to the exterior beam is severe. In addition to the spalling identified during the initial inspection, both the top and bottom flanges contain numerous cracks caused by the heat (photos 5 and 6). It appears those cracks extend at least 4 inches into the bottom flange. Hammer sounding the flanges indicated delamination of the beam concrete (photo 7). Eventually, this delaminated concrete will become loose and fall to the roadway surface below. Both the top and bottom flanges of the exterior beam have signs that the epoxy has melted off the reinforcing steel and oozed out of the concrete during the fire (photos 8, 9, and 10).

During fabrication, epoxy coated metal chairs are placed in the bottom of the beam to support the steel reinforcement and strands while the concrete is placed and cured. The feet of these chairs can be seen in the bottom flange of the fourth beam that does not appear to be damaged other than soot from the fire (photo 11). In the other three beams the epoxy from the chairs was melted, oozed, and re-hardened to hang from the bottom flange of the beam. Expectation is that you should see the feet of the metal chairs at the surface of the bottom flange. It appears that the epoxy oozes from holes in

the beam without the feet showing (photo 12). It is possible that the heat from the fire also melted the metal in the chairs. It would be impossible to say for sure without destructive testing of the remaining concrete to check for the chairs.

Looking at the interior face of the bottom flange of the exterior beam there are signs that the epoxy from the stirrups in the beam has melted and oozed out a crack in the side of the bottom flange (photo 8). The stirrups are shown as Z#5 bars in Exhibit 1. The stirrups provide capacity in the beams to resist shear. If the epoxy is melted or damaged on the stirrups, then the capacity of the beam is compromised.

It is not possible to determine the condition of the prestressing strands without destructive testing. The longitudinal view down the length of the beam does not show signs of a detrimental deflection (photo 13).

### **Recommendations:**

Olsson recommends that the shoulder of the bridge remain closed with cones or barrels. Due to the compromised strength of the beams and the unknown damage to the prestress strands, Olsson recommends replacing the two eastern most beams that were damaged. These beams should be replaced as soon as is practical. Continue to monitor the delaminated concrete so that if it becomes loose and falls action can be taken to protect the traffic below. The damage to the third beam damage appears to be limited and can be repaired in place by removing the delaminated concrete and patching it with pneumatic mortar and possibly fiber wrap.

If we can be of further assistance, please advise.

### **Photo Documentation:**



Photo 1: Burning tractor trailer and source of the intense heat that damaged the bridge





Photo 2: Type J prestressed concrete beams with metal stay-in-place deck forms. These are the three beams that are damaged.



Photo 3: Severe spalling of the concrete in the bottom flange of the exterior beam



Photo 4: Spalling of both flanges of the exterior beam, exterior face of the deck, and parapet

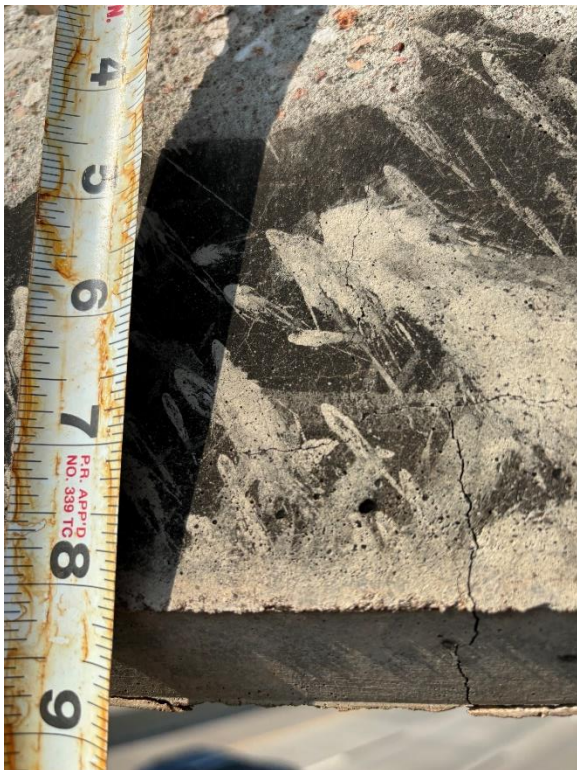

Photo 5: Crack damage of the bottom flange due to the extreme heat from the tractor trailer fire



Photo 6: Crack and spall of the bottom flange due to the extreme heat

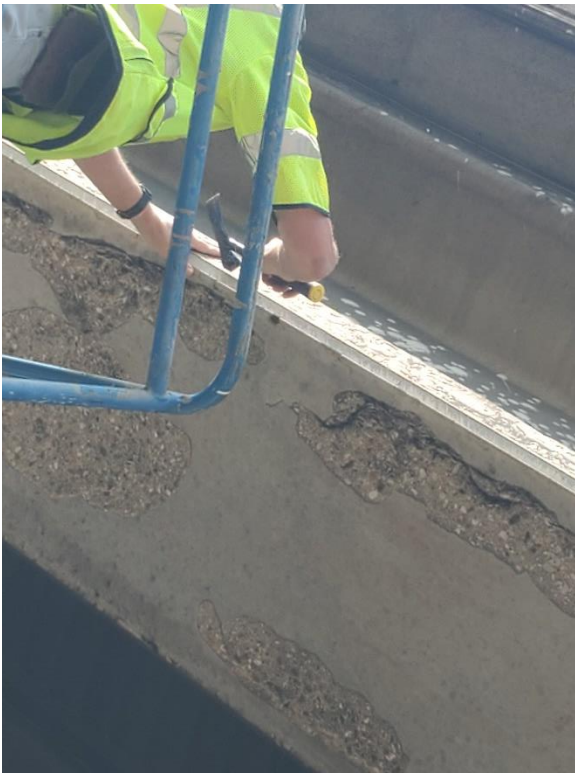

Photo 7: Hammer sounding and concrete damage from the extreme heat



Photo 8: Epoxy coating from the shear stirrups that oozed out of a crack in the interior side of the bottom flange of the exterior beam



Photo 9: Epoxy that oozed out of the top flange of the exterior beam and re-hardened



Photo 10: Epoxy that oozed out of the bottom of the bottom flange and re-hardened



Photo 11: Bottom flange of the fourth beam showing the typical condition of the chairs used in fabrication of the beams

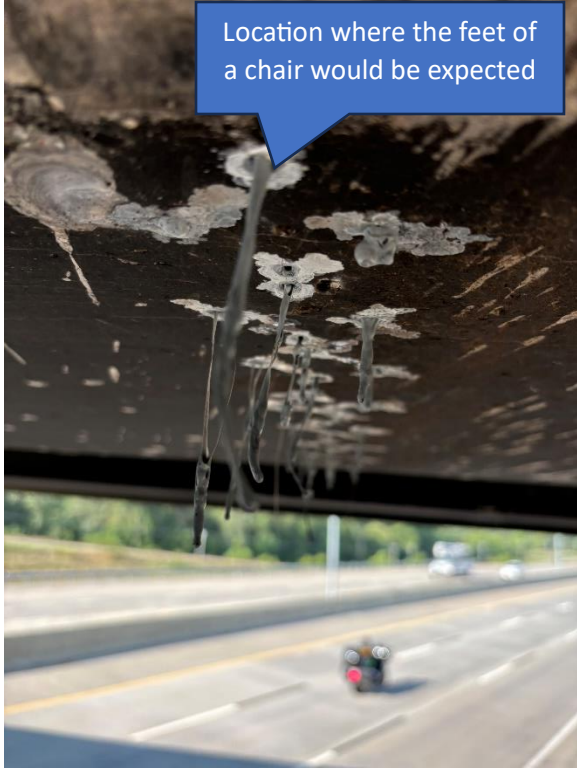

Location where the feet of a chair would be expected

Photo 12: Hardened epoxy that has oozed out of the bottom of the beam.



Photo 13: View looking down the length of the damaged exterior beam

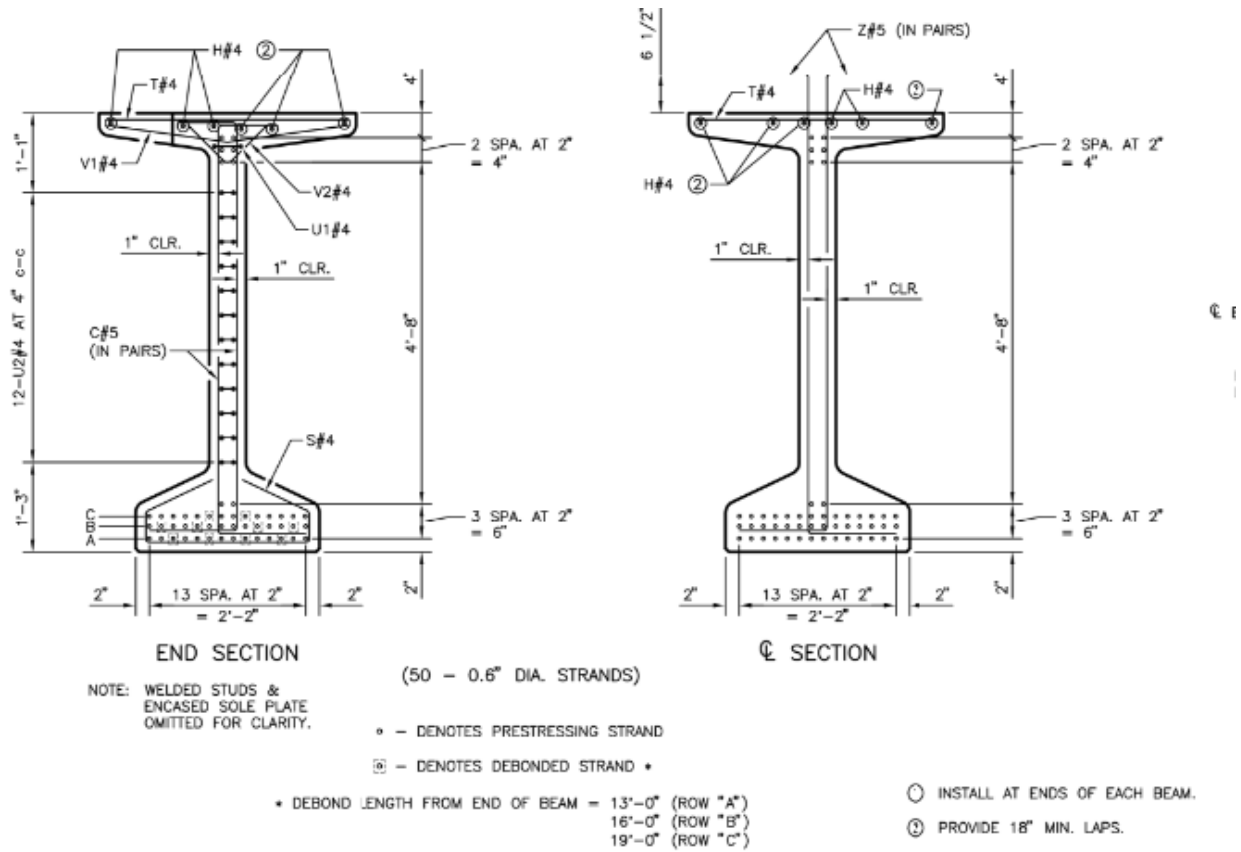

Exhibit 1: Plan Details Showing the Reinforcement of the Prestressed Beam

Oklahoma Dept. of Transportation - Bridge Inspection Report

<b>NBI No.:</b> 31858	<b>Structure No.:</b> 1937T3172 X	<b>Local ID:</b> 78.80	<b>Suff. Rating:</b> 98.00	<b>ND</b>																														
<b>Bridge Description:</b> 2-142ft. PCB SPANS, 26ft.-0in. CLR RDY, W/CONC. TRAFFIC RAILS (TR4) SKEW 30 DEGREES LT. FWD.		<b>IDENTIFICATION</b>																																
1. State: Oklahoma 2. Division: Division 8 3. County: CREEK 4. City: SAPULPA Admin Area: Turner TP 5a. On/Under: Route On Structure 5b. Kind of Hwy: County Hwy 5c. Lvl of Svc: Mainline 5d. Route No.: 03845 5e. Dir. Sufx: N/A (NBI)		7. Facility Carried: CO RD N3845 6. Fcst: TURNER TP (I-44) UNDER 9. 78.8 NE JCT I-35 11. Mile Post: 51.037 mi 13. LRS / Sub Rte: / 16. Latitude: 36° 00' 08.29" 17. Longitude: 096° 08' 37.09" 98. Border: Unknown (P) % Responsible: 0.00 99. Border Brdg #:																																
<b>STRUCTURE TYPE AND MATERIALS</b>		<b>INSPECTION</b>																																
43a/b. Main Span: P/S Conc. / Stringer/Girder 44a/b. Appr. Span: N/A / Not Applicable (P) 45. # of Main Spans: 2 46. # of Appr. Spans: 0 107. Deck Type: Concrete-Cast-in-Place 108a. Wearing Surface: Monolithic Concrete 108b. Membrane: None 108c. Deck protection: Epoxy Coated Reinforc		<table border="1" style="width:100%; border-collapse: collapse;"> <thead> <tr> <th>Type</th> <th>Insp. Req.</th> <th>Insp. Done</th> <th>Freq.</th> <th>Insp. Date</th> <th>Next Insp.</th> </tr> </thead> <tbody> <tr> <td>NBI:</td> <td></td> <td>1</td> <td>24 months</td> <td>6/20/2024</td> <td>06/20/2026</td> </tr> <tr> <td>FC:</td> <td>N</td> <td>0</td> <td></td> <td>NA</td> <td>NA</td> </tr> <tr> <td>UW:</td> <td>N</td> <td>0</td> <td></td> <td>NA</td> <td>NA</td> </tr> <tr> <td>OS:</td> <td>N</td> <td>0</td> <td></td> <td>NA</td> <td>NA</td> </tr> </tbody> </table>			Type	Insp. Req.	Insp. Done	Freq.	Insp. Date	Next Insp.	NBI:		1	24 months	6/20/2024	06/20/2026	FC:	N	0		NA	NA	UW:	N	0		NA	NA	OS:	N	0		NA	NA
Type	Insp. Req.	Insp. Done	Freq.	Insp. Date	Next Insp.																													
NBI:		1	24 months	6/20/2024	06/20/2026																													
FC:	N	0		NA	NA																													
UW:	N	0		NA	NA																													
OS:	N	0		NA	NA																													
<b>AGE AND SERVICE</b>		<b>CLASSIFICATION</b>																																
19. Detour Length: 2.0 mi 27. Year Built: 2018 28a/b. Lanes on/und: 2 / 6 29. ADT: 100 30. Year of ADT: 2022 42a/b. Type of Svc on/und: Highway / Highway		12. Base Hwy Net: Not on Base Network 20. Toll Facility: On free road 21. Custodian: Turnpike 22. Owner: Turnpike 26. Function Class: 07 Rural Mjr Collecto 37. Historical Sig.: Not eligible for NHRP 100. Def. Hwy: Not a STRAHNET hwy																																
<b>GEOMETRIC DATA</b>		<b>CONDITION</b>																																
10. Vert. Clearance: 99.99 ft 32. Appr Rwy Width: 24.00 ft 33. Median: Open median 34. Skew: 30.00° 35. Struct. Flared: No flare 47. Horizontal Cir: 24.00 ft 48. Length Max Span: 142.00 ft 49. Struct. Length: 286.00 ft		58. Deck: 9 Excellent 62. Culvert: N/A (NBI) 61. Chan./Chan. Prot.: N/A (NBI) 60. Sub: 9 Excellent 60. Sub: 9 Excellent																																
<b>OKLAHOMA ITEMS</b>		<b>LOAD RATING AND POSTING</b>																																
200c. Temperature: 79 200d. Weather: Cloudy 201. Struc. Stl. ASTM Desig.: / 202. Waterprf. Membrane: Date Installed: 203. Type Exp. Device: Open Joint-No Device Sealed Expansion Joint: - 204. Type of Railing: TR-4 205. Material Quantity: 208a. Type of Abutment: Skeleton b. Type of Found.: Steel Piling 209. Type of Pier/Found.: 2 / No Drilled Shaft 210. Foundation Elev.: 211. Wear. Surf. Prot. Sys: Date Installed: 211c. Silane Reapplied 211d. Date : 213. Utilities Attached:		31. Design Load: HL 93 41. Post. Status: A Open, no restriction 70. Posting: 5 Ab/Above Legal Loads 63. Op / 65. Inv. Rating Meth.: 3 LRFR Load & Res. Fg 3 LRFR Load & Res. Fa <table border="1" style="width:100%; border-collapse: collapse;"> <thead> <tr> <th></th> <th>H</th> <th>HS</th> <th>3-3</th> <th>EV3</th> <th>SHV</th> </tr> </thead> <tbody> <tr> <td>64. Operating Rating (tons):</td> <td>59.20</td> <td>59.20</td> <td>52.90</td> <td>60.40</td> <td>66.20</td> </tr> <tr> <td>66. Inventory Rating (tons):</td> <td>40.70</td> <td>40.70</td> <td>0.00</td> <td>0.00</td> <td></td> </tr> </tbody> </table>				H	HS	3-3	EV3	SHV	64. Operating Rating (tons):	59.20	59.20	52.90	60.40	66.20	66. Inventory Rating (tons):	40.70	40.70	0.00	0.00													
	H	HS	3-3	EV3	SHV																													
64. Operating Rating (tons):	59.20	59.20	52.90	60.40	66.20																													
66. Inventory Rating (tons):	40.70	40.70	0.00	0.00																														
214a. Posted Weight Limit: NR b. Posted Speed Limit: 45 c. Narrow/1way Brdg Sign: No d. Vertical Cir. Sign: Yes Adv. Warning Sign: No e. Navigation Lights?: No Working/Not Working: No 215. Overpass: TURNER TP 218. Functionally Obsolete: - 220. Bridge Redecked: - 221. Substr. Cond.(UW): 222. Fill Over RCB: 223. Appr. Slab/Rwy Cond.: 1 225. Paint Type/Dvrc: 226. Date Painted: 227. Paint Color: 233. Deck Forming: Perm. Metal Deck Form 238. School Bus Rte.: Current bus route 240. Appr. Rwy Type.: Asphalt/Bituminous 243. Grdr Spacing/No.: 7.50 / 4		<b>APPRAISAL</b>																																
214a. Posted Weight Limit: NR b. Posted Speed Limit: 45 c. Narrow/1way Brdg Sign: No d. Vertical Cir. Sign: Yes Adv. Warning Sign: No e. Navigation Lights?: No Working/Not Working: No 215. Overpass: TURNER TP 218. Functionally Obsolete: - 220. Bridge Redecked: - 221. Substr. Cond.(UW): 222. Fill Over RCB: 223. Appr. Slab/Rwy Cond.: 1 225. Paint Type/Dvrc: 226. Date Painted: 227. Paint Color: 233. Deck Forming: Perm. Metal Deck Form 238. School Bus Rte.: Current bus route 240. Appr. Rwy Type.: Asphalt/Bituminous 243. Grdr Spacing/No.: 7.50 / 4		36a. Brdg Rail: 1 Meets Standards 36b. Transition: 1 Meets Standards 36c. Appr. Rail: 1 Meets Standards 36d. Appr. Rail Ends: 1 Meets Standard 67. Str Evaluation: 9 Above Desirable																																
214a. Posted Weight Limit: NR b. Posted Speed Limit: 45 c. Narrow/1way Brdg Sign: No d. Vertical Cir. Sign: Yes Adv. Warning Sign: No e. Navigation Lights?: No Working/Not Working: No 215. Overpass: TURNER TP 218. Functionally Obsolete: - 220. Bridge Redecked: - 221. Substr. Cond.(UW): 222. Fill Over RCB: 223. Appr. Slab/Rwy Cond.: 1 225. Paint Type/Dvrc: 226. Date Painted: 227. Paint Color: 233. Deck Forming: Perm. Metal Deck Form 238. School Bus Rte.: Current bus route 240. Appr. Rwy Type.: Asphalt/Bituminous 243. Grdr Spacing/No.: 7.50 / 4		<b>PROPOSED IMPROVEMENT</b>																																
214a. Posted Weight Limit: NR b. Posted Speed Limit: 45 c. Narrow/1way Brdg Sign: No d. Vertical Cir. Sign: Yes Adv. Warning Sign: No e. Navigation Lights?: No Working/Not Working: No 215. Overpass: TURNER TP 218. Functionally Obsolete: - 220. Bridge Redecked: - 221. Substr. Cond.(UW): 222. Fill Over RCB: 223. Appr. Slab/Rwy Cond.: 1 225. Paint Type/Dvrc: 226. Date Painted: 227. Paint Color: 233. Deck Forming: Perm. Metal Deck Form 238. School Bus Rte.: Current bus route 240. Appr. Rwy Type.: Asphalt/Bituminous 243. Grdr Spacing/No.: 7.50 / 4		94. Bridge Cost: \$-1 95. Roadway Cost: \$-1 96. Total Cost: \$-1 97. Yr. of Cost Est.: 2015 75. Type of Work: Unknown (P) 76. Lngth of Improvement: -1.0 ft 114. Future ADT: 160 115. Yr. of Future ADT: 2042																																
214a. Posted Weight Limit: NR b. Posted Speed Limit: 45 c. Narrow/1way Brdg Sign: No d. Vertical Cir. Sign: Yes Adv. Warning Sign: No e. Navigation Lights?: No Working/Not Working: No 215. Overpass: TURNER TP 218. Functionally Obsolete: - 220. Bridge Redecked: - 221. Substr. Cond.(UW): 222. Fill Over RCB: 223. Appr. Slab/Rwy Cond.: 1 225. Paint Type/Dvrc: 226. Date Painted: 227. Paint Color: 233. Deck Forming: Perm. Metal Deck Form 238. School Bus Rte.: Current bus route 240. Appr. Rwy Type.: Asphalt/Bituminous 243. Grdr Spacing/No.: 7.50 / 4		<b>NAVIGATION DATA</b>																																
214a. Posted Weight Limit: NR b. Posted Speed Limit: 45 c. Narrow/1way Brdg Sign: No d. Vertical Cir. Sign: Yes Adv. Warning Sign: No e. Navigation Lights?: No Working/Not Working: No 215. Overpass: TURNER TP 218. Functionally Obsolete: - 220. Bridge Redecked: - 221. Substr. Cond.(UW): 222. Fill Over RCB: 223. Appr. Slab/Rwy Cond.: 1 225. Paint Type/Dvrc: 226. Date Painted: 227. Paint Color: 233. Deck Forming: Perm. Metal Deck Form 238. School Bus Rte.: Current bus route 240. Appr. Rwy Type.: Asphalt/Bituminous 243. Grdr Spacing/No.: 7.50 / 4		38. Nav. Control: NA-no waterway 39. Vert. Clearance: 0.0 ft 40. Horiz. Clearance: 0.0 ft 111. Pier Protect.: Not Applicable (P) 116. Ltr Bridge Vert. Chr.: 0.0 ft 244. Span Lengths: 142 142 245. Girder Depth: 6.00 246a. Type of Overlay: NA b. Overlay Thickness: c. Overlay Date: 01/01/2001 d. Ovlly Depth Changed >1": - 247. Protective Systems: 248. # Field Splices w/ Corrosion: 249. Scour Crit. POA Exists?: 250. Headwall: 258. Plans w/Found. in ODOT File 259. Scour Eval. in ODOT File: 263. Interchange at Intersection: No 264. Interstate Milepoint:																																



## Oklahoma Dept. of Transportation - Bridge Inspection Report

<b>NBI No.:</b> 31858	<b>Structure No.:</b> 1937T3172 X	<b>Local ID:</b> 78.80	<b>Suff. Rating:</b> 98.00	<b>ND</b>
Inspection Date: 6/20/24		Bill Childress		
Invoice No.: TURNER-24		Inspected With: Gayla Brown		

**BRIDGE NOTES:**

MINOR CRACKS IN THE NORTH SLOPEWALL

**INSPECTION NOTES:** 6/20/24

V.C. EAST BOUND POSTED 1701 MEAS 1706 . WEST BOUND POSTED 1701 MEAS 1703.

**ELEMENT CONDITION STATE DATA**

Elem. / Env	Description	Unit	Total Qty	% 1	Qty. 1	% 2	Qty. 2	% 3	Qty. 3	% 4	Qty. 4
12 / 1	Re Concrete Deck	sq.ft	6,864.00	100%	6,864.00	0%	0.00	0%	0.00	0%	0.00
109 / 1	Pre Opn Conc Girder/Beam	ft	1,034.00	100%	1,034.00	0%	0.00	0%	0.00	0%	0.00
205 / 1	Re Conc Column	each	12.00	100%	12.00	0%	0.00	0%	0.00	0%	0.00
215 / 1	Re Conc Abutment	ft	64.00	100%	64.00	0%	0.00	0%	0.00	0%	0.00
923 / 1	Conc Substr Prot Coa	sq.ft	576.00	100%	576.00	0%	0.00	0%	0.00	0%	0.00
CISM 1000 ON CAP AND ABUTMENTS.											
234 / 1	Re Conc Pier Cap	ft	32.00	100%	32.00	0%	0.00	0%	0.00	0%	0.00
310 / 1	Elastomeric Bearing	each	16.00	100%	16.00	0%	0.00	0%	0.00	0%	0.00
321 / 1	Re Conc Approach Slab	sq.ft	2.00	100%	2.00	0%	0.00	0%	0.00	0%	0.00
331 / 1	Re Conc Bridge Railing	ft	572.00	100%	572.00	0%	0.00	0%	0.00	0%	0.00
819 / 1	PS Conc.Gird.End(5Ft	ft	80.00	100%	80.00	0%	0.00	0%	0.00	0%	0.00
870 / 1	Concrete Wingwall	each	4.00	100%	4.00	0%	0.00	0%	0.00	0%	0.00
890 / 1	Steel SIP Form	each	1.00	100%	1.00	0%	0.00	0%	0.00	0%	0.00
906 / 1	Sealed Exp.Jt.(SEJ-3	ft	32.00	100%	32.00	0%	0.00	0%	0.00	0%	0.00
909 / 1	Pourable Fix Jt.Seal	ft	64.00	100%	64.00	0%	0.00	0%	0.00	0%	0.00
916 / 1	St.Bearing Assembly	each	16.00	100%	16.00	0%	0.00	0%	0.00	0%	0.00

# 2024 Capital Plan Projects



2024 Capital Plan Projects	Project Information	Adopted Budget (1)	Awarded To Date (2)	Charges To Date (3)	Remaining Balance (2)-(3)
<b>DESIGN</b>		<b>\$675,348</b>	<b>\$1,496,462</b>	<b>\$1,226,671</b>	<b>\$269,791</b>
<b>CONSTRUCTION</b>		<b>\$100,760,363</b>	<b>\$63,307,649</b>	<b>\$30,255,906</b>	<b>\$33,051,743</b>
<b>CONSTRUCTION MANAGEMENT/TESTING</b>		<b>\$4,220,828</b>	<b>\$1,401,525</b>	<b>\$272,306</b>	<b>\$1,129,218</b>
<b>2024 Totals</b>		<b>\$105,656,539</b>	<b>\$66,205,635</b>	<b>\$31,754,884</b>	<b>\$34,450,752</b>
<b>C-MC-34</b>	<b>Project Information</b>	<b>Adopted Budget</b>	<b>Awarded To Date</b>	<b>Charges To Date</b>	<b>Remaining Balance</b>
<b>Bridge 48.58 Rehabilitation</b>					
DESIGN	MacArthur	\$7,600	\$0	\$0	\$0
CONSTRUCTION	Haskell Lemon	\$2,644,006	\$3,365,315	\$2,187,156	\$1,178,159
CONSTRUCTION MANAGEMENT/TESTING	EST	\$211,520	\$0	\$0	\$0
<b>SUBTOTAL</b>		<b>\$2,863,126</b>	<b>\$3,365,315</b>	<b>\$2,187,156</b>	<b>\$1,178,159</b>
<b>C-MC-36</b>	<b>Project Information</b>	<b>Adopted Budget</b>	<b>Awarded To Date</b>	<b>Charges To Date</b>	<b>Remaining Balance</b>
<b>Bridge 32.97 Rehabilitation</b>					
DESIGN	Conzor	\$184,358	\$184,358	\$88,297	\$96,061
CONSTRUCTION	C3 Construction	\$2,170,524	\$2,662,277	\$0	\$2,662,277
CONSTRUCTION MANAGEMENT/TESTING	-	\$173,642	\$0	\$0	\$0
<b>SUBTOTAL</b>		<b>\$2,528,524</b>	<b>\$2,846,635</b>	<b>\$88,297</b>	<b>\$2,758,338</b>
<b>SP-71D</b>	<b>Project Information</b>	<b>Adopted Budget</b>	<b>Awarded To Date</b>	<b>Charges To Date</b>	<b>Remaining Balance</b>
<b>Creek Turnpike Riverside OHP Building</b>					
DESIGN	Guernsey	\$0	\$242,300	\$178,735	\$63,565
CONSTRUCTION	-	\$0	\$0	\$0	\$0
CONSTRUCTION MANAGEMENT/TESTING	-	\$0	\$0	\$0	\$0
<b>SUBTOTAL</b>		<b>\$0</b>	<b>\$242,300</b>	<b>\$178,735</b>	<b>\$63,565</b>
<b>HEB-MC-69A</b>	<b>Project Information</b>	<b>Adopted Budget</b>	<b>Awarded To Date</b>	<b>Charges To Date</b>	<b>Remaining Balance</b>
<b>Shoulder and Guardrail Rehabilitation MP 89-102</b>					
DESIGN	Freese & Nichols	\$50,000	\$242,300	\$201,700	\$40,600
CONSTRUCTION	TJ Campbell	\$8,856,000	\$8,638,938	\$1,865,494	\$6,773,444
CONSTRUCTION MANAGEMENT/TESTING	SRB	\$708,480	\$237,861	\$3,027	\$234,835
<b>SUBTOTAL</b>		<b>\$9,614,480</b>	<b>\$9,119,100</b>	<b>\$2,070,221</b>	<b>\$7,048,879</b>
<b>HEB-MC-69B</b>	<b>Project Information</b>	<b>Adopted Budget</b>	<b>Awarded To Date</b>	<b>Charges To Date</b>	<b>Remaining Balance</b>
<b>Shoulder and Guardrail Rehabilitation MP 62-78</b>					
DESIGN	Freese & Nichols	\$87,300	Design HEB-MC-69A	Design HEB-MC-69A	Design HEB-MC-69A
CONSTRUCTION	Haskell Lemon	\$8,798,000	\$8,919,730	\$7,060,294	\$1,859,436
CONSTRUCTION MANAGEMENT/TESTING	SRB	\$703,840	\$315,872	\$60,043	\$255,829
<b>SUBTOTAL</b>		<b>\$9,589,140</b>	<b>\$9,235,602</b>	<b>\$7,120,336</b>	<b>\$2,115,285</b>
<b>IN-MC-62H</b>	<b>Project Information</b>	<b>Adopted Budget</b>	<b>Awarded To Date</b>	<b>Charges To Date</b>	<b>Remaining Balance</b>
<b>Positive Barrier MP 52-70</b>					
DESIGN	EST	\$69,157	\$0	\$0	\$0
CONSTRUCTION	Built Right Construction	\$7,000,000	\$11,661,558	\$0	\$11,661,558
CONSTRUCTION MANAGEMENT/TESTING	-	\$560,000	\$0	\$0	\$0
<b>SUBTOTAL</b>		<b>\$7,629,157</b>	<b>\$11,661,558</b>	<b>\$0</b>	<b>\$11,661,558</b>
<b>IN-MC-68</b>	<b>Project Information</b>	<b>Adopted Budget</b>	<b>Awarded To Date</b>	<b>Charges To Date</b>	<b>Remaining Balance</b>
<b>Bridge 49.06 &amp; Bridge 53.50 Rehabilitation</b>					
DESIGN	EST	\$40,000	\$278,000	\$257,958	\$20,042
CONSTRUCTION	Built Right Construction	\$3,300,000	\$9,580,228	\$8,235,691	\$1,344,537
CONSTRUCTION MANAGEMENT/TESTING	-	\$264,000	\$0	\$0	\$0
<b>SUBTOTAL</b>		<b>\$3,604,000</b>	<b>\$9,858,228</b>	<b>\$8,493,649</b>	<b>\$1,364,579</b>
<b>IN-MC-74</b>	<b>Project Information</b>	<b>Adopted Budget</b>	<b>Awarded To Date</b>	<b>Charges To Date</b>	<b>Remaining Balance</b>
<b>Pavement Rehabilitation MP 94-104 NB</b>					
DESIGN	OTA	\$41,000	\$0	\$0	\$0
CONSTRUCTION	APAC	\$5,511,638	\$3,251,747	\$2,818,337	\$433,410
CONSTRUCTION MANAGEMENT/TESTING	Olsson	\$440,931	\$209,110	\$5,447	\$203,664
<b>SUBTOTAL</b>		<b>\$5,993,569</b>	<b>\$3,460,857</b>	<b>\$2,823,784</b>	<b>\$637,073</b>
<b>T-ER-041</b>	<b>Project Information</b>	<b>Adopted Budget</b>	<b>Awarded To Date</b>	<b>Charges To Date</b>	<b>Remaining Balance</b>
<b>Bridge 31.30 Emergency Repairs</b>					
DESIGN	Olsson	\$0	\$8,500	\$7,320	\$1,180
CONSTRUCTION	Built Right Construction	\$0	\$40,899	\$40,899	\$0
CONSTRUCTION MANAGEMENT/TESTING	-	\$0	\$0	\$0	\$0
<b>SUBTOTAL</b>		<b>\$0</b>	<b>\$49,399</b>	<b>\$48,219</b>	<b>\$1,180</b>
<b>T-MC-142</b>	<b>Project Information</b>	<b>Adopted Budget</b>	<b>Awarded To Date</b>	<b>Charges To Date</b>	<b>Remaining Balance</b>
<b>Pavement Rehabilitation MP 161-166 WB</b>					
DESIGN	Olsson	\$0	\$25,000	\$17,090	\$7,910
CONSTRUCTION	Ellsworth Construction	\$0	\$1,326,642	\$895,315	\$431,328
CONSTRUCTION MANAGEMENT/TESTING	-	\$0	\$0	\$0	\$0
<b>SUBTOTAL</b>		<b>\$0</b>	<b>\$1,351,642</b>	<b>\$912,405</b>	<b>\$439,238</b>
<b>WR-MC-139</b>	<b>Project Information</b>	<b>Adopted Budget</b>	<b>Awarded To Date</b>	<b>Charges To Date</b>	<b>Remaining Balance</b>
<b>Pavement Rehabilitation MP 325-329</b>					
DESIGN	Teim Design	\$0	\$149,500	\$132,600	\$16,900
CONSTRUCTION	APAC	\$48,000,000	\$6,589,990	\$484,306	\$6,105,684
CONSTRUCTION MANAGEMENT/TESTING	Lochner	\$0	\$301,191	\$91,433	\$209,668
<b>SUBTOTAL</b>		<b>\$48,000,000</b>	<b>\$7,040,591</b>	<b>\$708,339</b>	<b>\$6,332,252</b>
<b>WR-MC-140</b>	<b>Project Information</b>	<b>Adopted Budget</b>	<b>Awarded To Date</b>	<b>Charges To Date</b>	<b>Remaining Balance</b>
<b>Pavement Rehabilitation MP 260-265</b>					



# 2023 Capital Plan Projects



2023 Capital Plan Projects	Project Information	Adopted Budget (1)	Awarded To Date (2)	Charges To Date (3)	Remaining Balance (2)-(3)
<b>DESIGN</b>		<b>\$485,033</b>	<b>\$2,304,446</b>	<b>\$2,001,759</b>	<b>\$302,687</b>
<b>CONSTRUCTION</b>		<b>\$98,500,115</b>	<b>\$111,492,281</b>	<b>\$94,458,191</b>	<b>\$17,034,090</b>
<b>CONSTRUCTION MANAGEMENT/TESTING</b>		<b>\$3,150,000</b>	<b>\$6,571,514</b>	<b>\$3,109,720</b>	<b>\$3,461,793</b>
<b>2023 Totals</b>		<b>\$102,135,148</b>	<b>\$120,368,241</b>	<b>\$99,569,670</b>	<b>\$20,798,571</b>
<b>CHT-MC-11</b>	<b>Project Information</b>	<b>Adopted Budget</b>	<b>Awarded To Date</b>	<b>Charges To Date</b>	<b>Remaining Balance</b>
<b>Cable Barrier MP 0-32</b>					
DESIGN	TEIM	\$30,000	\$144,000	\$137,000	\$7,000
CONSTRUCTION	Sherwood	\$9,500,000	\$11,684,463	\$10,706,636	\$977,827
CONSTRUCTION MANAGEMENT/TESTING	Hudson Prince	\$210,000	\$591,909	\$471,023	\$120,886
<b>SUBTOTAL</b>		<b>\$9,740,000</b>	<b>\$12,420,372</b>	<b>\$11,314,660</b>	<b>\$1,105,713</b>
<b>CKT-ER-001</b>	<b>Project Information</b>	<b>Adopted Budget</b>	<b>Awarded To Date</b>	<b>Charges To Date</b>	<b>Remaining Balance</b>
<b>Riverside Gantry</b>					
DESIGN	Olsson	\$0	\$12,000	\$0	\$12,000
CONSTRUCTION	-	\$0	\$0	\$0	\$0
CONSTRUCTION MANAGEMENT/TESTING	-	\$0	\$0	\$0	\$0
<b>SUBTOTAL</b>		<b>\$0</b>	<b>\$12,000</b>	<b>\$0</b>	<b>\$12,000</b>
<b>C-MC-30</b>	<b>Project Information</b>	<b>Adopted Budget</b>	<b>Awarded To Date</b>	<b>Charges To Date</b>	<b>Remaining Balance</b>
<b>Bridge 22.50 Rehabilitation &amp; Positive Barrier</b>					
DESIGN	CP&Y	\$50,000	\$245,100	\$232,150	\$12,950
CONSTRUCTION	Frontier Bridge	\$6,900,000	\$10,068,225	\$7,110,185	\$2,958,040
CONSTRUCTION MANAGEMENT/TESTING	SRB	\$240,000	\$410,993	\$200,938	\$210,055
<b>SUBTOTAL</b>		<b>\$7,190,000</b>	<b>\$10,724,318</b>	<b>\$7,543,273</b>	<b>\$3,181,044</b>
<b>C-MC-34</b>	<b>Project Information</b>	<b>Adopted Budget</b>	<b>Awarded To Date</b>	<b>Charges To Date</b>	<b>Remaining Balance</b>
<b>Bridge 48.58 (MP 48.58) Rehabilitation</b>					
DESIGN	MacArthur	\$50,000	\$190,000	\$184,400	\$5,600
CONSTRUCTION	Haskell Lemon	\$2,300,000	\$3,365,315	\$2,187,156	\$1,178,159
CONSTRUCTION MANAGEMENT/TESTING	-	\$240,000	\$0	\$0	\$0
<b>SUBTOTAL</b>		<b>\$2,590,000</b>	<b>\$3,555,315</b>	<b>\$2,371,556</b>	<b>\$1,183,759</b>
<b>HEB-ER-013</b>	<b>Project Information</b>	<b>Adopted Budget</b>	<b>Awarded To Date</b>	<b>Charges To Date</b>	<b>Remaining Balance</b>
<b>Bridge 53.39A Emergency Repairs</b>					
DESIGN	Olsson	\$0	\$19,000	\$18,750	\$250
CONSTRUCTION	Built Right Construction	\$0	\$76,018	\$76,018	\$0
CONSTRUCTION MANAGEMENT/TESTING	SRB	\$0	\$15,276	\$4,459	\$10,816
<b>SUBTOTAL</b>		<b>\$0</b>	<b>\$110,294</b>	<b>\$99,228</b>	<b>\$11,066</b>
<b>HEB-ER-014</b>	<b>Project Information</b>	<b>Adopted Budget</b>	<b>Awarded To Date</b>	<b>Charges To Date</b>	<b>Remaining Balance</b>
<b>Bridge 51.00A Emergency Repairs</b>					
DESIGN	Olsson	\$0	\$22,500	\$21,234	\$1,266
CONSTRUCTION	-	\$0	\$0	\$0	\$0
CONSTRUCTION MANAGEMENT/TESTING	-	\$0	\$0	\$0	\$0
<b>SUBTOTAL</b>		<b>\$0</b>	<b>\$22,500</b>	<b>\$21,234</b>	<b>\$1,266</b>
<b>HEB-MC-65C</b>	<b>Project Information</b>	<b>Adopted Budget</b>	<b>Awarded To Date</b>	<b>Charges To Date</b>	<b>Remaining Balance</b>
<b>DBR/Grind MP 46-62</b>					
DESIGN	Atkins	\$0	\$0	\$0	\$0
CONSTRUCTION	Interstate Improvement	\$9,920,000	\$8,597,152	\$8,588,152	\$9,000
CONSTRUCTION MANAGEMENT/TESTING	Freese & Nichols	\$180,000	\$886,609	\$551,172	\$335,437
<b>SUBTOTAL</b>		<b>\$10,100,000</b>	<b>\$9,483,761</b>	<b>\$9,139,325</b>	<b>\$344,437</b>
<b>IN-MC-62F</b>	<b>Project Information</b>	<b>Adopted Budget</b>	<b>Awarded To Date</b>	<b>Charges To Date</b>	<b>Remaining Balance</b>
<b>DBR/Grind MP 52-70</b>					
DESIGN	EST	\$0	\$0	\$0	\$0
CONSTRUCTION	Diamond Surface	\$11,438,000	\$12,795,148	\$9,068,152	\$3,726,996
CONSTRUCTION MANAGEMENT/TESTING	Garver	\$210,000	\$621,678	\$114,140	\$507,538
<b>SUBTOTAL</b>		<b>\$11,648,000</b>	<b>\$13,416,826</b>	<b>\$9,182,292</b>	<b>\$4,234,534</b>
<b>IN-MC-62G</b>	<b>Project Information</b>	<b>Adopted Budget</b>	<b>Awarded To Date</b>	<b>Charges To Date</b>	<b>Remaining Balance</b>
<b>Cable Barrier MP 16-34</b>					
DESIGN	EST	\$85,033	\$0	\$0	\$0
CONSTRUCTION	Robinson	\$11,267,651	\$10,431,721	\$8,897,607	\$1,534,114
CONSTRUCTION MANAGEMENT/TESTING	Olsson	\$180,000	\$599,220	\$360,786	\$238,434
<b>SUBTOTAL</b>		<b>\$11,532,684</b>	<b>\$11,030,941</b>	<b>\$9,258,393</b>	<b>\$1,772,548</b>
<b>IN-MC-66</b>	<b>Project Information</b>	<b>Adopted Budget</b>	<b>Awarded To Date</b>	<b>Charges To Date</b>	<b>Remaining Balance</b>
<b>AET Conversion</b>					
DESIGN	Atkins	\$0	\$641,314	\$477,964	\$163,350
CONSTRUCTION	Built Right Construction	\$12,761,766	\$9,580,228	\$7,534,303	\$2,045,925
CONSTRUCTION MANAGEMENT/TESTING	Poe	\$220,000	\$818,792	\$271,300	\$547,492
<b>SUBTOTAL</b>		<b>\$12,981,766</b>	<b>\$11,040,334</b>	<b>\$8,283,567</b>	<b>\$2,756,766</b>
<b>IN-MC-67</b>	<b>Project Information</b>	<b>Adopted Budget</b>	<b>Awarded To Date</b>	<b>Charges To Date</b>	<b>Remaining Balance</b>
<b>Bridge 64.49 (MP 39.50) Rehabilitation</b>					
DESIGN	Tetra Tech	\$0	\$184,500	\$175,500	\$9,000
CONSTRUCTION	B&B Construction	\$2,650,000	\$2,932,535	\$2,707,056	\$225,479
CONSTRUCTION MANAGEMENT/TESTING	CEC	\$240,000	\$409,258	\$281,896	\$127,362
<b>SUBTOTAL</b>		<b>\$2,890,000</b>	<b>\$3,526,293</b>	<b>\$3,164,453</b>	<b>\$361,840</b>
<b>IN-MC-70B</b>	<b>Project Information</b>	<b>Adopted Budget</b>	<b>Awarded To Date</b>	<b>Charges To Date</b>	<b>Remaining Balance</b>
<b>Pavement Rehabilitation MP 20-30</b>					

2023 Capital Plan Projects	Project Information	Adopted Budget (1)	Awarded To Date (2)	Charges To Date (3)	Remaining Balance (2)-(3)
DESIGN	CP&Y	\$40,000	2022 Design	2022 Design	2022 Design
CONSTRUCTION	APAC	\$7,200,000	\$11,538,988	\$11,497,256	\$41,732
CONSTRUCTION MANAGEMENT/TESTING	CEC	\$180,000	\$227,130	\$185,868	\$41,261
<b>SUBTOTAL</b>		<b>\$7,420,000</b>	<b>\$11,766,117</b>	<b>\$11,683,124</b>	<b>\$82,994</b>
<b>T-ER-034</b>	<b>Project Information</b>	<b>Adopted Budget</b>	<b>Awarded To Date</b>	<b>Charges To Date</b>	<b>Remaining Balance</b>
<b>Bridge 31.30 Emergency Repairs</b>					
DESIGN	Olsson	\$0	\$7,000	\$7,000	\$0
CONSTRUCTION	Logos Construction	\$0	\$78,787	\$78,787	\$0
CONSTRUCTION MANAGEMENT/TESTING	SRB	\$0	\$0	\$0	\$0
<b>SUBTOTAL</b>		<b>\$0</b>	<b>\$85,787</b>	<b>\$85,787</b>	<b>\$0</b>
<b>T-ER-035</b>	<b>Project Information</b>	<b>Adopted Budget</b>	<b>Awarded To Date</b>	<b>Charges To Date</b>	<b>Remaining Balance</b>
<b>Bridge 31.30 Emergency Repairs</b>					
DESIGN	Olsson	\$0	\$8,000	\$7,764	\$236
CONSTRUCTION	Logos/Manhattan	\$0	\$78,717	\$78,717	\$0
CONSTRUCTION MANAGEMENT/TESTING	SRB	\$0	\$0	\$0	\$0
<b>SUBTOTAL</b>		<b>\$0</b>	<b>\$86,717</b>	<b>\$86,481</b>	<b>\$236</b>
<b>T-ER-036</b>	<b>Project Information</b>	<b>Adopted Budget</b>	<b>Awarded To Date</b>	<b>Charges To Date</b>	<b>Remaining Balance</b>
<b>Bridge 44.20 Emergency Repairs</b>					
DESIGN	Olsson	\$0	\$17,000	\$15,116	\$1,884
CONSTRUCTION	Built Right Construction	\$0	\$50,531	\$50,531	\$0
CONSTRUCTION MANAGEMENT/TESTING	SRB	\$0	\$0	\$0	\$0
<b>SUBTOTAL</b>		<b>\$0</b>	<b>\$67,531</b>	<b>\$65,647</b>	<b>\$1,884</b>
<b>T-ER-037</b>	<b>Project Information</b>	<b>Adopted Budget</b>	<b>Awarded To Date</b>	<b>Charges To Date</b>	<b>Remaining Balance</b>
<b>Bridge 31.30 Emergency Repairs</b>					
DESIGN	Olsson	\$0	\$57,000	\$53,255	\$3,745
CONSTRUCTION	Built Right Construction	\$0	\$463,909	\$463,909	\$0
CONSTRUCTION MANAGEMENT/TESTING	SRB	\$0	\$44,120	\$14,885	\$29,235
<b>SUBTOTAL</b>		<b>\$0</b>	<b>\$565,029</b>	<b>\$532,049</b>	<b>\$32,980</b>
<b>T-ER-038</b>	<b>Project Information</b>	<b>Adopted Budget</b>	<b>Awarded To Date</b>	<b>Charges To Date</b>	<b>Remaining Balance</b>
<b>Bridge 31.30 Emergency Repairs</b>					
DESIGN	Olsson	\$0	\$12,500	\$11,600	\$900
CONSTRUCTION	Built Right Construction	\$0	\$169,620	\$169,620	\$0
CONSTRUCTION MANAGEMENT/TESTING	SRB	\$0	\$7,957	\$5,937	\$2,020
<b>SUBTOTAL</b>		<b>\$0</b>	<b>\$190,077</b>	<b>\$187,157</b>	<b>\$2,920</b>
<b>T-ER-039</b>	<b>Project Information</b>	<b>Adopted Budget</b>	<b>Awarded To Date</b>	<b>Charges To Date</b>	<b>Remaining Balance</b>
<b>Bridge 31.30 Emergency Repairs</b>					
DESIGN	Olsson	\$0	\$14,000	\$12,796	\$1,204
CONSTRUCTION	Built Right Construction	\$0	\$86,258	\$86,258	\$0
CONSTRUCTION MANAGEMENT/TESTING	-	\$0	\$0	\$0	\$0
<b>SUBTOTAL</b>		<b>\$0</b>	<b>\$100,258</b>	<b>\$99,055</b>	<b>\$1,204</b>
<b>T-ER-040</b>	<b>Project Information</b>	<b>Adopted Budget</b>	<b>Awarded To Date</b>	<b>Charges To Date</b>	<b>Remaining Balance</b>
<b>Bridge 44.20 Emergency Repairs</b>					
DESIGN	Olsson	\$0	\$9,000	\$8,804	\$197
CONSTRUCTION	Built Right Construction	\$0	\$317,050	\$317,050	\$0
CONSTRUCTION MANAGEMENT/TESTING	-	\$0	\$0	\$0	\$0
<b>SUBTOTAL</b>		<b>\$0</b>	<b>\$326,050</b>	<b>\$325,854</b>	<b>\$197</b>
<b>T-MC-128B</b>	<b>Project Information</b>	<b>Adopted Budget</b>	<b>Awarded To Date</b>	<b>Charges To Date</b>	<b>Remaining Balance</b>
<b>Stroud Service Plaza Reconstruction</b>					
DESIGN	Olsson	\$50,000	\$0	\$0	\$0
CONSTRUCTION	-	\$7,000,000	ACCESS Program	ACCESS Program	ACCESS Program
CONSTRUCTION MANAGEMENT/TESTING	-	\$450,000	ACCESS Program	ACCESS Program	ACCESS Program
<b>SUBTOTAL</b>		<b>\$7,500,000</b>	<b>\$0</b>	<b>\$0</b>	<b>\$0</b>
<b>T-MC-128C</b>	<b>Project Information</b>	<b>Adopted Budget</b>	<b>Awarded To Date</b>	<b>Charges To Date</b>	<b>Remaining Balance</b>
<b>Bridge 43.30 and Frontage Road</b>					
DESIGN	Olsson	\$0	2019 Design	2019 Design	2019 Design
CONSTRUCTION	Sherwood	\$0	\$8,647,657	\$7,719,196	\$928,461
CONSTRUCTION MANAGEMENT/TESTING	CEC	\$0	\$587,235	\$101,842	\$485,392
<b>SUBTOTAL</b>		<b>\$0</b>	<b>\$9,234,892</b>	<b>\$7,821,038</b>	<b>\$1,413,854</b>
<b>T-MC-131</b>	<b>Project Information</b>	<b>Adopted Budget</b>	<b>Awarded To Date</b>	<b>Charges To Date</b>	<b>Remaining Balance</b>
<b>Bridge 22.10 (MP 157.50) Reconstruction</b>					
DESIGN	CEC	\$40,000	2017 Design	2017 Design	2017 Design
CONSTRUCTION	Sherwood	\$4,000,000	ACCESS Program	ACCESS Program	ACCESS Program
CONSTRUCTION MANAGEMENT/TESTING	-	\$170,000	ACCESS Program	ACCESS Program	ACCESS Program
<b>SUBTOTAL</b>		<b>\$4,210,000</b>	<b>\$0</b>	<b>\$0</b>	<b>\$0</b>
<b>WR-MC-138</b>	<b>Project Information</b>	<b>Adopted Budget</b>	<b>Awarded To Date</b>	<b>Charges To Date</b>	<b>Remaining Balance</b>
<b>Pavement Rehabilitation MP 265-270</b>					
DESIGN	MKEC	\$20,000	\$119,803	\$105,653	\$14,150
CONSTRUCTION	Robinson Construction	\$4,562,698	\$5,207,891	\$4,957,613	\$250,278
CONSTRUCTION MANAGEMENT/TESTING	Garver	\$120,000	\$210,007	\$203,065	\$6,942
<b>SUBTOTAL</b>		<b>\$4,702,698</b>	<b>\$5,537,701</b>	<b>\$5,266,330</b>	<b>\$271,371</b>
<b>WR-MC-143</b>	<b>Project Information</b>	<b>Adopted Budget</b>	<b>Awarded To Date</b>	<b>Charges To Date</b>	<b>Remaining Balance</b>
<b>Pavement Rehabilitation MP 307-312</b>					
DESIGN	Olsson	\$20,000	\$50,000	\$28,672	\$21,328
CONSTRUCTION	APAC	\$3,000,000	\$4,948,501	\$4,948,501	\$0

2023 Capital Plan Projects	Project Information	Adopted Budget (1)	Awarded To Date (2)	Charges To Date (3)	Remaining Balance (2)-(3)
CONSTRUCTION MANAGEMENT/TESTING	Craig & Keithline	\$150,000	\$194,781	\$149,363	\$45,418
<b>SUBTOTAL</b>		<b>\$3,170,000</b>	<b>\$5,193,282</b>	<b>\$5,126,536</b>	<b>\$66,746</b>
<b>SP-63A (Turner)</b>	<b>Project Information</b>	<b>Adopted Budget</b>	<b>Awarded To Date</b>	<b>Charges To Date</b>	<b>Remaining Balance</b>
AET Conversion					
DESIGN	HNTB	\$50,000	\$248,365	\$227,370	\$20,995
CONSTRUCTION	Robinson Construction	\$3,000,000	\$4,311,547	\$4,295,985	\$15,563
CONSTRUCTION MANAGEMENT/TESTING	Tetra Tech/Benchmark	\$180,000	\$396,706	\$63,165	\$333,541
<b>SUBTOTAL</b>		<b>\$3,230,000</b>	<b>\$4,956,618</b>	<b>\$4,586,519</b>	<b>\$370,099</b>
<b>SP-63B (Will Rogers)</b>	<b>Project Information</b>	<b>Adopted Budget</b>	<b>Awarded To Date</b>	<b>Charges To Date</b>	<b>Remaining Balance</b>
AET Conversion					
DESIGN	HNTB	\$50,000	\$248,365	\$227,370	\$20,995
CONSTRUCTION	Robinson Construction	\$3,000,000	\$5,681,980	\$2,539,463	\$3,142,517
CONSTRUCTION MANAGEMENT/TESTING	Tetra Tech/Benchmark	\$180,000	\$463,599	\$95,007	\$368,592
<b>SUBTOTAL</b>		<b>\$3,230,000</b>	<b>\$6,393,944</b>	<b>\$2,861,841</b>	<b>\$3,532,104</b>
<b>SP-70</b>	<b>Project Information</b>	<b>Adopted Budget</b>	<b>Awarded To Date</b>	<b>Charges To Date</b>	<b>Remaining Balance</b>
Service Plaza Monuments					
DESIGN	Olsson	\$0	\$55,000	\$49,362	\$5,638
CONSTRUCTION	Cantera Concrete	\$0	\$380,039	\$380,039	\$0
CONSTRUCTION MANAGEMENT/TESTING	SRB	\$0	\$86,244	\$34,872	\$51,372
<b>SUBTOTAL</b>		<b>\$0</b>	<b>\$521,283</b>	<b>\$464,273</b>	<b>\$57,010</b>

# 2022 CAPITAL PLAN PROJECTS

7/31/2024

TOTAL 2022 CAPITAL PROJECTS	OTA Adopted Budget (1)	Revised Budget (2)	Awarded To Date (3)	Charges To Date (4)	Remaining Balance (2) - (4)
DESIGN	3,121,000	1,494,278	1,494,278	1,274,890	218,430
CONSTRUCTION	106,320,100	64,923,027	64,923,027	63,593,249	1,329,779
CONSTRUCTION MANAGEMENT/TESTING	3,627,000	6,994,483	6,994,483	6,295,277	699,206
<b>TOTAL</b>	<b>\$ 113,068,100</b>	<b>\$ 73,411,788</b>	<b>\$ 73,411,788</b>	<b>\$ 71,163,416</b>	<b>\$ 2,247,414</b>

SP-62 Cherokee Turnpike AET Conversion	Project Information	OTA Adopted Budget	Revised Budget	Awarded To Date	Charges To Date	Remaining Balance
DESIGN	HNTB	3,000	94,625	94,625	47,437	47,188
CONSTRUCTION	-	100,000	-	-	-	-
CONSTRUCTION MANAGEMENT/TESTING	-	-	-	-	-	-
<b>SUBTOTAL</b>		<b>\$ 103,000</b>	<b>\$ 94,625</b>	<b>\$ 94,625</b>	<b>\$ 47,437</b>	<b>\$ 47,188</b>

C-MC-29 AET Conversion	Project Information	OTA Adopted Budget	Revised Budget	Awarded To Date	Charges To Date	Remaining Balance
DESIGN	Cowan	300,000	DESIGN IN 2021 CAPITAL PLAN			-
CONSTRUCTION (Includes CKT-MC-23)	Manhattan	15,000,000	22,897,416	22,897,416	22,632,186	265,230
CONSTRUCTION MANAGEMENT/TESTING	Poe	360,000	1,854,189	1,854,189	1,716,032	138,157
<b>SUBTOTAL</b>		<b>\$ 15,660,000</b>	<b>\$ 24,751,605</b>	<b>\$ 24,751,605</b>	<b>\$ 24,348,219</b>	<b>\$ 403,387</b>

C-MC-33C Cimarron Spur Positive Barrier MP 20A-28A	Project Information	OTA Adopted Budget	Revised Budget	Awarded To Date	Charges To Date	Remaining Balance
DESIGN	Cabiness/Garver	-	DESIGN COMBINED WITH C-MC-33A, 2019			-
CONSTRUCTION	Manhattan	3,840,100	5,085,434	5,085,434	5,085,434	-
CONSTRUCTION MANAGEMENT/TESTING	Benchmark	90,000	327,103	327,103	296,441	30,662
<b>SUBTOTAL</b>		<b>\$ 3,930,100</b>	<b>\$ 5,412,537</b>	<b>\$ 5,412,537</b>	<b>\$ 5,381,875</b>	<b>\$ 30,662</b>

GKT-MC-23 AET Conversion	Project Information	OTA Adopted Budget	Revised Budget	Awarded To Date	Charges To Date	Remaining Balance
DESIGN	Atkins	300,000	213,444	213,444	84,104	129,340
CONSTRUCTION	Manhattan	15,000,000	CONSTRUCTION COMBINED WITH C-MC-29			-
CONSTRUCTION MANAGEMENT/TESTING	Poe	360,000	CONSTRUCTION COMBINED WITH C-MC-29			-
<b>SUBTOTAL</b>		<b>\$ 15,660,000</b>	<b>\$ 213,444</b>	<b>\$ 213,444</b>	<b>\$ 84,104</b>	<b>\$ 129,340</b>

HEB-MC-65B DBR/Diamond Grind MP 62-78	Project Information	OTA Adopted Budget	Revised Budget	Awarded To Date	Charges To Date	Remaining Balance
DESIGN	Atkins	-	DESIGN COMBINED WITH HEB-MC-65A, 2019			-
CONSTRUCTION	Emory Sapp	10,080,000	7,695,569	7,695,569	7,644,313	51,256
CONSTRUCTION MANAGEMENT/TESTING	Freese & Nichols	-	655,383	655,383	652,266	3,117
<b>SUBTOTAL</b>		<b>\$ 10,080,000</b>	<b>\$ 8,350,952</b>	<b>\$ 8,350,952</b>	<b>\$ 8,296,579</b>	<b>\$ 54,373</b>

HEB-MC-67B AET Conversion	Project Information	OTA Adopted Budget	Revised Budget	Awarded To Date	Charges To Date	Remaining Balance
DESIGN	Olsson	240,000	DESIGN IN 2021 ( HEB-MC-67A)			-
CONSTRUCTION	Duit	7,500,000	17,521,533	17,521,533	16,407,305	1,114,228
CONSTRUCTION MANAGEMENT/TESTING	Atkins	300,000	1,032,095	1,032,095	1,006,759	25,336
<b>SUBTOTAL</b>		<b>\$ 8,040,000</b>	<b>\$ 18,553,628</b>	<b>\$ 18,553,628</b>	<b>\$ 17,414,065</b>	<b>\$ 1,139,564</b>

GREEN = PROJECT THROUGH AUDIT/FINALED  
 RED = PROJECT RE-PROGRAMMED/CANCELED  
 BLUE = PORTION FUNDED WITH 2011 BOND PROCEEDS

# 2022 CAPITAL PLAN PROJECTS

7/31/2024

IN-MC-62 Positive Barrier MP 0-16	Project Information	OTA Adopted Budget	Revised Budget	Awarded To Date	Charges To Date	Remaining Balance
DESIGN	EST	240,000	DESIGN IN 2019 CAPITAL PLAN (IN-MC-62A)			-
CONSTRUCTION	Built Right	5,400,000	11,005,189	11,005,189	11,005,189	-
CONSTRUCTION MANAGEMENT/TESTING	Olsson	240,000	720,411	720,411	569,044	151,367
<b>SUBTOTAL</b>		<b>\$ 5,880,000</b>	<b>\$ 11,725,600</b>	<b>\$ 11,725,600</b>	<b>\$ 11,574,233</b>	<b>\$ 151,367</b>

IN-MC-65 Bridge 66.37 Rehab	Project Information	OTA Adopted Budget	Revised Budget	Awarded To Date	Charges To Date	Remaining Balance
DESIGN	W2M	209,000	209,000	209,000	209,000	-
CONSTRUCTION	B&B Construction	4,100,000	3,031,534	3,031,534	3,031,534	-
CONSTRUCTION MANAGEMENT/TESTING	EST	192,000	339,340	339,340	339,340	-
<b>SUBTOTAL</b>		<b>\$ 4,501,000</b>	<b>\$ 3,579,874</b>	<b>\$ 3,579,874</b>	<b>\$ 3,579,874</b>	<b>\$ -</b>

IN-MC-64 (Mandatory Tie to IN-MC-70A) Pavement Rehab MP 0-10	Project Information	OTA Adopted Budget	Revised Budget	Awarded To Date	Charges To Date	Remaining Balance
DESIGN	Garver	119,000	101,904	101,904	101,904	-
CONSTRUCTION (Includes IN-MC-70A)	Overland Corp.	5,800,000	13,068,595	13,068,595	13,068,595	-
CONSTRUCTION MANAGEMENT/TESTING	Olsson	90,000	631,823	631,823	631,823	-
<b>SUBTOTAL</b>		<b>\$ 6,009,000</b>	<b>\$ 13,802,322</b>	<b>\$ 13,802,322</b>	<b>\$ 13,802,322</b>	<b>\$ -</b>

IN-MC-70A (Mandatory Tie to IN-MC-64) Pavement Rehab MP 10-20	Project Information	OTA Adopted Budget	Revised Budget	Awarded To Date	Charges To Date	Remaining Balance
DESIGN	CP&Y	180,000	179,890	179,890	179,890	-
CONSTRUCTION	Overland Corp.	6,000,000	CONSTRUCTION COMBINED WITH IN-MC-64			-
CONSTRUCTION MANAGEMENT/TESTING	Olsson	90,000	CONSTRUCTION COMBINED WITH IN-MC-64			-
<b>SUBTOTAL</b>		<b>\$ -</b>	<b>\$ 179,890</b>	<b>\$ 179,890</b>	<b>\$ 179,890</b>	<b>\$ -</b>

JKT-MC-15 (ODOT) JKT/Memorial Interchange Improvements	Project Information	OTA Adopted Budget	Revised Budget	Awarded To Date	Charges To Date	Remaining Balance
DESIGN	ODOT (Olsson)	190,000	PROJECT DESIGN BY ODOT			-
CONSTRUCTION	Allen/Shell	3,000,000	4,358,225	4,358,225	4,358,225	-
CONSTRUCTION MANAGEMENT/TESTING	Freese and Nichols	200,000	396,999	396,999	369,486	27,512
<b>SUBTOTAL</b>		<b>\$ 3,390,000</b>	<b>\$ 4,755,224</b>	<b>\$ 4,755,224</b>	<b>\$ 4,727,712</b>	<b>\$ 27,512</b>

MU-MC-49 AET Conversion	Project Information	OTA Adopted Budget	Revised Budget	Awarded To Date	Charges To Date	Remaining Balance
DESIGN	Garver	160,000	495,948	495,948	458,946	37,002
CONSTRUCTION	Duit	4,000,000	9,754,319	9,754,319	9,599,978	154,341
CONSTRUCTION MANAGEMENT/TESTING	Poe	360,000	748,871	748,871	486,744	262,127
<b>SUBTOTAL</b>		<b>\$ 4,520,000</b>	<b>\$ 10,999,138</b>	<b>\$ 10,999,138</b>	<b>\$ 10,545,667</b>	<b>\$ 453,471</b>

T-ER-030 Bridge 31.20 Emergency Repairs	Project Information	OTA Adopted Budget	Revised Budget	Awarded To Date	Charges To Date	Remaining Balance
DESIGN	Olsson	-	6,000	6,000	5,516	-
CONSTRUCTION	Built Right	-	39,007	39,007	39,007	-
CONSTRUCTION MANAGEMENT/TESTING	Benchmark	-	1,822	1,822	1,822	-
<b>SUBTOTAL</b>		<b>\$ -</b>	<b>\$ 46,829</b>	<b>\$ 46,829</b>	<b>\$ 46,345</b>	<b>\$ -</b>

GREEN = PROJECT THROUGH AUDIT/FINALED  
 RED = PROJECT RE-PROGRAMMED/CANCELED  
 BLUE = PORTION FUNDED WITH 2011 BOND PROCEEDS



# 2022 CAPITAL PLAN PROJECTS

7/31/2024

T-ER-031 Bridge 57.00 Emergency Repairs	Project Information	OTA Adopted Budget	Revised Budget	Awarded To Date	Charges To Date	Remaining Balance
DESIGN	Olsson	-	13,000	13,000	12,526	-
CONSTRUCTION	Built Right	-	119,816	119,816	119,816	-
CONSTRUCTION MANAGEMENT/TESTING	Benchmark	-	4,369	4,369	4,369	-
<b>SUBTOTAL</b>		<b>\$ -</b>	<b>\$ 137,185</b>	<b>\$ 137,185</b>	<b>\$ 136,711</b>	<b>\$ -</b>

T-ER-032 Bridge 61.20 Emergency Repairs	Project Information	OTA Adopted Budget	Revised Budget	Awarded To Date	Charges To Date	Remaining Balance
DESIGN	-	-	-	-	-	-
CONSTRUCTION	Built Right	-	23,000	23,000	23,000	-
CONSTRUCTION MANAGEMENT/TESTING	-	-	-	-	-	-
<b>SUBTOTAL</b>		<b>\$ -</b>	<b>\$ 23,000</b>	<b>\$ 23,000</b>	<b>\$ 23,000</b>	<b>\$ -</b>

T-ER-033 Bridge 61.20 Emergency Repairs	Project Information	OTA Adopted Budget	Revised Budget	Awarded To Date	Charges To Date	Remaining Balance
DESIGN	Olsson	-	21,385	21,385	21,385	-
CONSTRUCTION	Logos	-	33,722	33,722	33,722	-
CONSTRUCTION MANAGEMENT/TESTING	SRB	-	ON-DEMAND			-
<b>SUBTOTAL</b>		<b>\$ -</b>	<b>\$ 55,107</b>	<b>\$ 55,107</b>	<b>\$ 55,107</b>	<b>\$ -</b>

T-MC-128B Stroud Service Plaza Modernization	Project Information	OTA Adopted Budget	Revised Budget	Awarded To Date	Charges To Date	Remaining Balance
DESIGN	Olsson	500,000	DESIGN IN 2019 CAPITAL PLAN			-
CONSTRUCTION	-	10,000,000	MOVED TO ACCESS BOND PROGRAM			-
CONSTRUCTION MANAGEMENT/TESTING	-	450,000	MOVED TO ACCESS BOND PROGRAM			-
<b>SUBTOTAL</b>		<b>\$ 10,950,000</b>	<b>\$ -</b>	<b>\$ -</b>	<b>\$ -</b>	<b>\$ -</b>

T-MC-139 Pavement Rehab MP 179-184	Project Information	OTA Adopted Budget	Revised Budget	Awarded To Date	Charges To Date	Remaining Balance
DESIGN	Haff	90,000	137,564	137,564	132,664	4,900
CONSTRUCTION	Haskell Lemon	3,500,000	4,033,016	4,033,016	4,023,062	9,953
CONSTRUCTION MANAGEMENT/TESTING	HNTB	150,000	173,868	173,868	158,898	14,970
<b>SUBTOTAL</b>		<b>\$ 3,740,000</b>	<b>\$ 4,344,448</b>	<b>\$ 4,344,448</b>	<b>\$ 4,314,624</b>	<b>\$ 29,823</b>

T-MC-131 Br. 22.10 N&S Over US-66 Reconstruction	Project Information	OTA Adopted Budget	Revised Budget	Awarded To Date	Charges To Date	Remaining Balance
DESIGN	CEC	400,000	DESIGN IN 2017 CAPITAL PLAN			-
CONSTRUCTION	-	14,000,000	MOVED TO ACCESS BOND PROGRAM			-
CONSTRUCTION MANAGEMENT/TESTING	-	170,000	MOVED TO ACCESS BOND PROGRAM			-
<b>SUBTOTAL</b>		<b>\$ 14,570,000</b>	<b>\$ -</b>	<b>\$ -</b>	<b>\$ -</b>	<b>\$ -</b>

WR-MC-131 Flint Road Interchange	Project Information	OTA Adopted Budget	Revised Budget	Awarded To Date	Charges To Date	Remaining Balance
DESIGN	MKEC	100,000	DESIGN IN 2017 CAPITAL PLAN			-
CONSTRUCTION	-	16,000,000	-	-	-	-
CONSTRUCTION MANAGEMENT/TESTING	-	420,000	-	-	-	-
<b>SUBTOTAL</b>		<b>\$ 16,520,000</b>	<b>\$ -</b>	<b>\$ -</b>	<b>\$ -</b>	<b>\$ -</b>

GREEN = PROJECT THROUGH AUDIT/FINALED  
 RED = PROJECT RE-PROGRAMMED/CANCELED  
 BLUE = PORTION FUNDED WITH 2011 BOND PROCEEDS

# 2022 CAPITAL PLAN PROJECTS

7/31/2024

WR-MC-141 Pavement Rehab MP 298-302	Project Information	OTA Adopted Budget	Revised Budget	Awarded To Date	Charges To Date	Remaining Balance
DESIGN	Olsson	90,000	21,518	21,518	21,518	-
CONSTRUCTION	APAC	3,800,000	2,222,663	2,222,663	2,222,663	-
CONSTRUCTION MANAGEMENT/TESTING	C&K	155,000	108,210	108,210	62,252	45,958
<b>SUBTOTAL</b>		<b>\$ 4,045,000</b>	<b>\$ 2,352,391</b>	<b>\$ 2,352,391</b>	<b>\$ 2,306,433</b>	<b>\$ 45,958</b>



# Letting Schedule

8/2/2024

CONTRACT NO.	PROJECT DESCRIPTION	Plan Submittal to OTA Project Manager (Drop Dead Date)	ADVERTISEMENT DATE	PRE-BID QUESTION CUT-OFF	BID OPENING A/B	BID OPENING DATE	AWARD DATE	ESTIMATED CONSTRUCTION <b>PART "A" only</b>
<b>NOVEMBER 2023 LETTING / DECEMBER 2023 AWARD</b>								
IN-MC-66 JP 35314(04)	Indian Nation Turnpike All Electronic Tolling (AET) Conversion	Friday, August 25, 2023	Thursday, October 12, 2023	Friday, October 20, 2023	A	Thursday, November 9, 2023	Tuesday, December 12, 2023	\$6,312,289
T-MC-107A1 JP 35686(04) T-26712A ACCESS	Turner Turnpike Creek County Grading, Drainage, and Surfacing Near MP 197-200 Mandatory tie to T-MC-107A2 and T-MC-107B3	Friday, August 25, 2023	Thursday, October 12, 2023	Friday, October 20, 2023	A	Thursday, November 9, 2023	Tuesday, December 12, 2023	\$51,148,219
T-MC-107A2 JP 35686(05) T-26712B ACCESS	Turner Turnpike Creek County Grading, Drainage, and Surfacing Near MP 199.97-203.07 Mandatory tie to T-MC-107A1 and T-MC-107B3	Friday, August 25, 2023	Thursday, October 12, 2023	Friday, October 20, 2023	A	Thursday, November 9, 2023	Tuesday, December 12, 2023	\$52,888,668
T-MC-107B3 JP 35686(06) T-26612A ACCESS	Turner Turnpike, Creek County Proposed Interchange at SH- 66 Grading, Drainage, and Surfacing Near MP 203-204.5 Mandatory tie to T-MC-107A1 and T-MC-107A2	Friday, August 25, 2023	Thursday, October 12, 2023	Friday, October 20, 2023	A	Thursday, November 9, 2023	Tuesday, December 12, 2023	\$7,412,508
T-ER-040	Turner Turnpike Lincoln County Emergency Bridge Repair Br 44.20 MP 179.50						Tuesday, December 12, 2023	\$250,000
<b>DECEMBER 2023 LETTING / JANUARY 2024 AWARD</b>								
		Friday, September 29, 2023	Thursday, November 16, 2023	Friday, November 24, 2023	B	Thursday, December 14, 2023	Tuesday, January 9, 2024	
<b>JANUARY 2024 LETTING / FEBRUARY 2024 AWARD</b>								
C-MC-34 JP 35817(04) Div 8	Cimarron Turnpike Pawnee County Bridge 48.58 Rehab over BNSF (MP 48.58)	Friday, November 3, 2023	Thursday, December 21, 2023	Friday, December 29, 2023	B	Thursday, January 18, 2024	Tuesday, February 6, 2024	\$2,537,123
<b>FEBRUARY 2024 LETTING / MARCH 2024 AWARD</b>								
WR-MC-144 JP 36530(04)	Will Rogers Turnpike Craig County Asphalt Pavement Rehabilitation MP 290-298	Friday, December 1, 2023	Thursday, January 18, 2024	Friday, January 26, 2024	B	Thursday, February 15, 2024	Tuesday, March 5, 2024	\$8,994,692
SP-63B JP 35954(05)	Will Rogers AET (Cashless Conversion)	Friday, December 1, 2023	Thursday, January 18, 2024	Friday, January 26, 2024	B	Thursday, February 15, 2024	Tuesday, March 5, 2024	\$4,542,082
<b>MARCH 2024 LETTING / APRIL 2024 AWARD</b>								
HEB-MC-69A JP 36617(04) Div 7	H.E. Bailey Turnpike Grady County Shoulder and Guardrail Reconstruction MP 89-101.6	Friday, December 29, 2023	Thursday, February 22, 2024	Friday, March 1, 2024	B	Thursday, March 21, 2024	Tuesday, April 2, 2024	\$10,352,658
HEB-MC-69B JP 36618(04) Div 7	H.E. Bailey Turnpike Comanche, Caddo, and Grady Counties Shoulder and Guardrail Reconstruction MP 62-78	Friday, December 29, 2023	Thursday, February 22, 2024	Friday, March 1, 2024	B	Thursday, March 21, 2024	Tuesday, April 2, 2024	\$11,592,520
IN-MC-74 JP 36643(04)	Indian Nation Turnpike McIntosh and Okmulgee Counties Asphalt Pavement Rehabilitation MP 96.1-104.7	Friday, December 29, 2023	Thursday, February 22, 2024	Friday, March 1, 2024	B	Thursday, March 21, 2024	Tuesday, April 2, 2024	\$3,633,921
WR-MC-139 JP 35814(04)	Will Rogers Turnpike Ottawa County Asphalt Pavement Rehabilitation MP 325.0-329.6	Friday, December 29, 2023	Thursday, February 22, 2024	Friday, March 1, 2024	B	Thursday, March 21, 2024	Tuesday, April 2, 2024	\$5,575,472
<b>APRIL 2024 LETTING / MAY 2024 AWARD</b>								
T-ER-041 JP 36767(04)	Turner Turnpike Lincoln County Emergency Bridge Repair 31.30	Friday, January 26, 2024	Thursday, March 21, 2024	Friday, March 29, 2024	B	Thursday, April 18, 2024	Tuesday, May 14, 2024	\$28,740
<b>MAY 2024 LETTING / JUNE 2024 AWARD</b>								
T-MC-142 JP 36707(04)	Turner Turnpike Lincoln County Pavement Rehabilitation MP 161 - 166 Westbound Only	Friday, February 23, 2024	Thursday, April 18, 2024	Friday, April 26, 2024	B	Thursday, May 16, 2024	Tuesday, June 4, 2024	\$1,422,250
ITB 2024-004	Creek Turnpike Tulsa County Drainage Structure Repair Bridge 5.88		Thursday, May 2, 2024	Friday, May 17, 2024	OTA Internal Bidding Process through Purchasing Division	Thursday, May 30, 2024	Tuesday, June 4, 2024	\$50,000
<b>JUNE 2024 LETTING / JULY 2024 AWARD (TENTATIVE)</b>								
IN-MC-62H JP 35827(04) mandatorily tied to IN-MC-68 IN-MC-68 JP 35832(04) mandatorily tied to IN-MC-62H IN-MC-69 JP 35839(04) Tied to IN-MC-68, USING ONE PROJECT NUMBER	Indian Nation Turnpike Pittsburgh County Cable Barrier MP 52-63 Indian Nation Turnpike Pittsburgh County Bridge Rehabilitation Br 49.06 MP 54.95 (SH-63) Indian Nation Turnpike Pittsburgh County Bridge Rehabilitation Br 50.5 MP 53.5	Friday, March 29, 2024	Thursday, May 23, 2024	Friday, May 31, 2024	B	Thursday, June 20, 2024	Tuesday, July 9, 2024	\$8,839,831
		Friday, March 29, 2024	Thursday, May 23, 2024	Friday, May 31, 2024	B	Thursday, June 20, 2024	Tuesday, July 9, 2024	\$3,991,416
<b>JULY 2024 LETTING / AUGUST 2024 AWARD (TENTATIVE)</b>								
C-MC-36 JP 36615(04)	Cimarron Turnpike Payne County Bridge Rehabilitation, Bridge No. 32.97 near M.P. 32.97	Friday, April 26, 2024	Thursday, June 20, 2024	Friday, June 28, 2024	B	Thursday, July 18, 2024	Tuesday, August 6, 2024	\$2,996,076
<b>AUGUST 2024 LETTING / SEPTEMBER 2024 AWARD (TENTATIVE)</b>								
T-MC-128B JP 35309(04) ACCESS	Turner Turnpike Lincoln County Pavement Widening & Stroud Service Plaza Modernization	Friday, May 24, 2024	Thursday, July 18, 2024	Friday, July 26, 2024	B	Thursday, August 15, 2024	Tuesday, September 10, 2024	\$33,306,698
<b>SEPTEMBER 2024 LETTING / OCTOBER 2024 AWARD (TENTATIVE)</b>								
IN-MC-73 JP 36526(04)	Indian Nation Turnpike Pushmataha County Bridge Rehabilitation Br. 91.02 (MP 13.35)	Friday, June 28, 2024	Thursday, August 22, 2024	Friday, August 30, 2024	B	Thursday, September 19, 2024	Tuesday, October 8, 2024	\$4,352,485
<b>OCTOBER 2024 LETTING / NOVEMBER 2024 AWARD (TENTATIVE)</b>								
JP 37300(06) JKT-30005 JKT-30705A ACCESS	John Kilpatrick Turnpike Oklahoma County Grade, Drain, and Surface MP 132-135	Friday, July 26, 2024	Thursday, September 19, 2024	Friday, September 27, 2024	B	Thursday, October 17, 2024	Tuesday, November 5, 2024	\$16,000,000
MU-MC-52 JP 36528(04)	Muskogee Turnpike Muskogee County Bridge Rehabilitation Br. 41.16 (MP 41.16)	Friday, July 26, 2024	Thursday, September 19, 2024	Friday, September 27, 2024	B	Thursday, October 17, 2024	Tuesday, November 5, 2024	\$2,951,690
<b>NOVEMBER 2024 LETTING / DECEMBER 2024 AWARD (TENTATIVE)</b>								
C-MC-37 JP 36609(04)	Cimarron Turnpike Noble, Payne, and Pawnee Counties Shoulder and Guardrail Reconstruction MP 21-40	Friday, August 30, 2024	Thursday, October 24, 2024	Friday, November 1, 2024	B	Thursday, November 21, 2024	Tuesday, December 10, 2024	\$10,879,712
IN-MC-71A JP 36524(04)	Indian Nation Turnpike Atoka, Pittsburg, and Pushmataha Counties Shoulder and Guardrail Reconstruction MP 32-45	Friday, August 30, 2024	Thursday, October 24, 2024	Friday, November 1, 2024	B	Thursday, November 21, 2024	Tuesday, December 10, 2024	\$7,853,696
MU-MC-53 JP 36529(05)	Muskogee Turnpike Wagoner County Concrete Pavement Reconstruction MP 12-19	Friday, August 30, 2024	Thursday, October 24, 2024	Friday, November 1, 2024	B	Thursday, November 21, 2024	Tuesday, December 10, 2024	\$41,407,613
SP-71D	QHP Facility at Riverside Maintenance Facility, Creek Turnpike	Friday, August 30, 2024	Thursday, October 24, 2024	Friday, November 1, 2024	B	Thursday, November 21, 2024	Tuesday, December 10, 2024	\$4,000,000
SP-72A	John Kilpatrick Turnpike Oklahoma County Wilshire Exit Cashlane-Toll Improvements	Friday, August 30, 2024	Thursday, October 24, 2024	Friday, November 1, 2024	B	Thursday, November 21, 2024	Tuesday, December 10, 2024	TBD



# Letting Schedule

8/2/2024

CONTRACT NO.	PROJECT DESCRIPTION	Plan Submittal to OTA Project Manager (Drop Dead Date)	ADVERTISEMENT DATE	PRE-BID QUESTION CUT-OFF	BID OPENING A/B	BID OPENING DATE	AWARD DATE	ESTIMATED CONSTRUCTION <b>PART "A" only</b>
MU-MC-51A JP 36527(04)	Muskogee Turnpike Muskogee County DBR/Grind Project MP 37-56	Friday, August 30, 2024	Thursday, October 24, 2024	Friday, November 1, 2024	B	Thursday, November 21, 2024	Tuesday, December 10, 2024	\$14,937,205
IN-MC-72A JP 36525(04)	Indian Nation Turnpike McIntosh County Bridge Rehabilitation Br. 15.83 (MP 88.17)	Friday, August 30, 2024	Thursday, October 24, 2024	Friday, November 1, 2024	B	Thursday, November 21, 2024	Tuesday, December 10, 2024	\$2,233,550
<b>DECEMBER 2024 LETTING / JANUARY 2025 AWARD (TENTATIVE)</b>								
	NO ODOT DECEMBER LETTING	Friday, September 27, 2024	Thursday, November 21, 2024	Friday, November 29, 2024	B	Thursday, December 19, 2024	Tuesday, January 7, 2025	
<b>JANUARY 2025 LETTING / FEBRUARY 2025 AWARD (TENTATIVE)</b>								
WR-MC-140 JP 35828(04)	Will Rogers Turnpike Rogers and Mayes Counties Asphalt Pavement Rehabilitation MP 260-265	Friday, October 25, 2024	Thursday, December 19, 2024	Friday, December 27, 2024	B	Thursday, January 16, 2025	Tuesday, February 4, 2025	\$5,513,365
SP-71A	OTA Maintenance Building at Heyburn	Friday, October 25, 2024	Thursday, December 19, 2024	Friday, December 27, 2024	B	Thursday, January 16, 2025	Tuesday, February 4, 2025	\$1,500,000
HEB-MC-69C JP 36619(04) Div 7	H.E. Bailey Turnpike Comanche County Shoulder and Guardrail Reconstruction MP 46.2-62	Friday, October 25, 2024	Thursday, December 19, 2024	Friday, December 27, 2024	B	Thursday, January 16, 2025	Tuesday, February 4, 2025	\$9,825,898
<b>FEBRUARY 2025 LETTING / MARCH 2025 AWARD (TENTATIVE)</b>								
		Friday, November 29, 2024	Thursday, January 16, 2025	Friday, January 24, 2025	B	Thursday, February 13, 2025	Tuesday, March 4, 2025	
<b>MARCH 2025 LETTING / APRIL 2025 AWARD (TENTATIVE)</b>								
		Friday, December 27, 2024	Thursday, February 20, 2025	Friday, February 28, 2025	B	Thursday, March 20, 2025	Tuesday, April 8, 2025	
<b>APRIL 2025 LETTING / MAY 2025 AWARD (TENTATIVE)</b>								
		Friday, January 17, 2025	Thursday, March 13, 2025	Friday, March 21, 2025	B	Thursday, April 10, 2025	Tuesday, May 6, 2025	
<b>MAY 2025 LETTING / JUNE 2025 AWARD (TENTATIVE)</b>								
IN-MC-72B JP 36525(05)	Indian Nation Turnpike Pittsburg County Bridge Rehabilitation Br. 40.84 (MP 63.10)	Friday, February 21, 2025	Thursday, April 17, 2025	Friday, April 25, 2025	B	Thursday, May 15, 2025	Tuesday, June 3, 2025	\$3,151,500
<b>JUNE 2025 LETTING / JULY 2025 AWARD (TENTATIVE)</b>								
MU-MC-54 JP #####(04)	Muskogee Turnpike Muskogee County Bridge Rehabilitation Br. 32.20 (MP 32.20)	Friday, March 21, 2025	Thursday, May 15, 2025	Friday, May 23, 2025	B	Thursday, June 12, 2025	Tuesday, July 1, 2025	\$4,000,000
<b>JULY 2025 LETTING / AUGUST 2025 AWARD (TENTATIVE)</b>								
		Friday, April 25, 2025	Thursday, June 19, 2025	Friday, June 27, 2025	B	Thursday, July 17, 2025	Tuesday, August 5, 2025	
<b>AUGUST 2025 LETTING / SEPTEMBER 2025 AWARD (TENTATIVE)</b>								
IN-MC-62D JP 35820(04)	Indian Nation Turnpike Pushmataha, Pittsburg and Atoka Counties DBR/Grind MP 30-52	Friday, May 23, 2025	Thursday, July 17, 2025	Friday, July 25, 2025	B	Thursday, August 14, 2025	Tuesday, September 9, 2025	\$13,905,114

# Oklahoma Turnpike Authority

Monthly Board Presentation | August 2024

## OTA Debt Maturities (\$ in Millions)

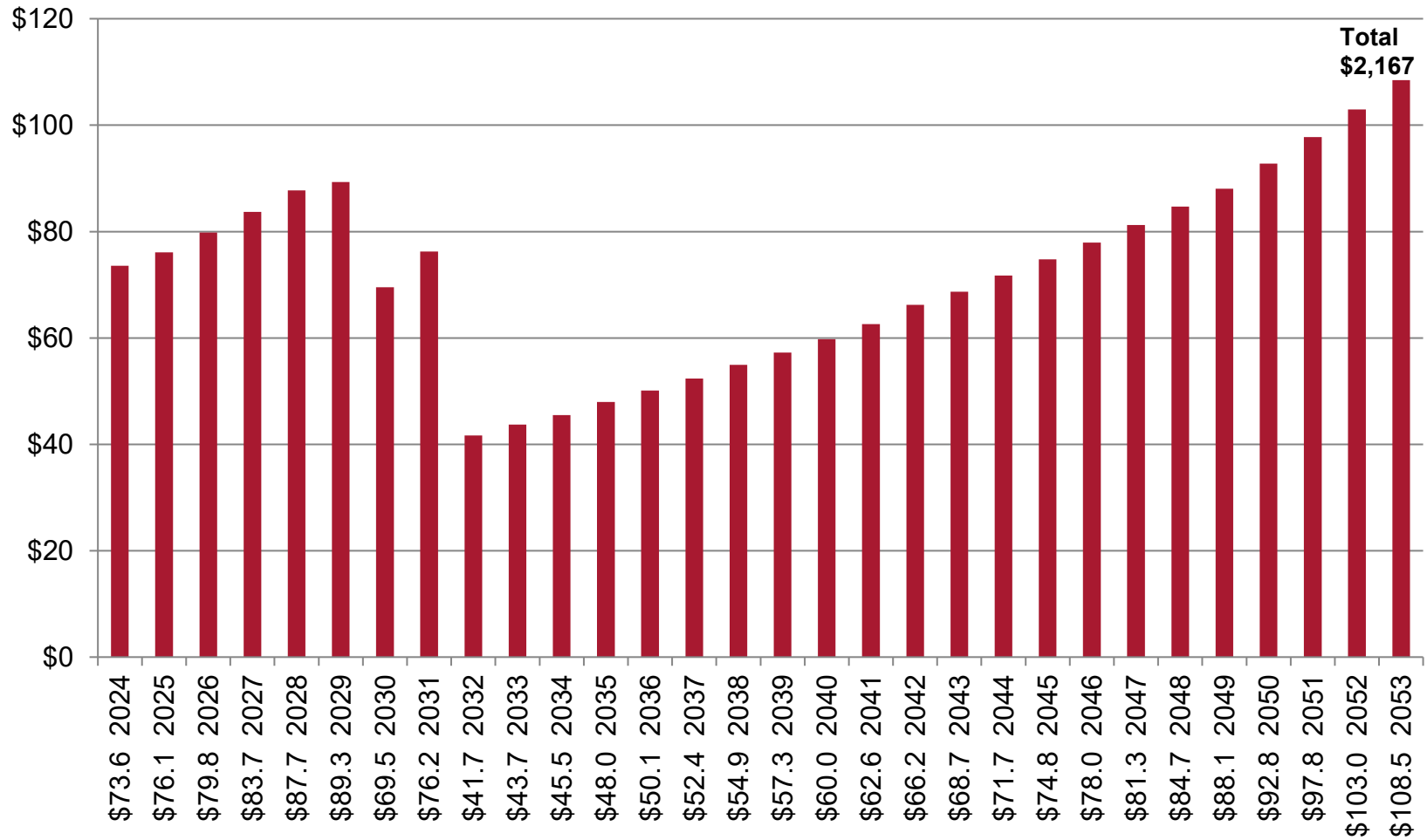

## Total OTA Funds (at Market Value)

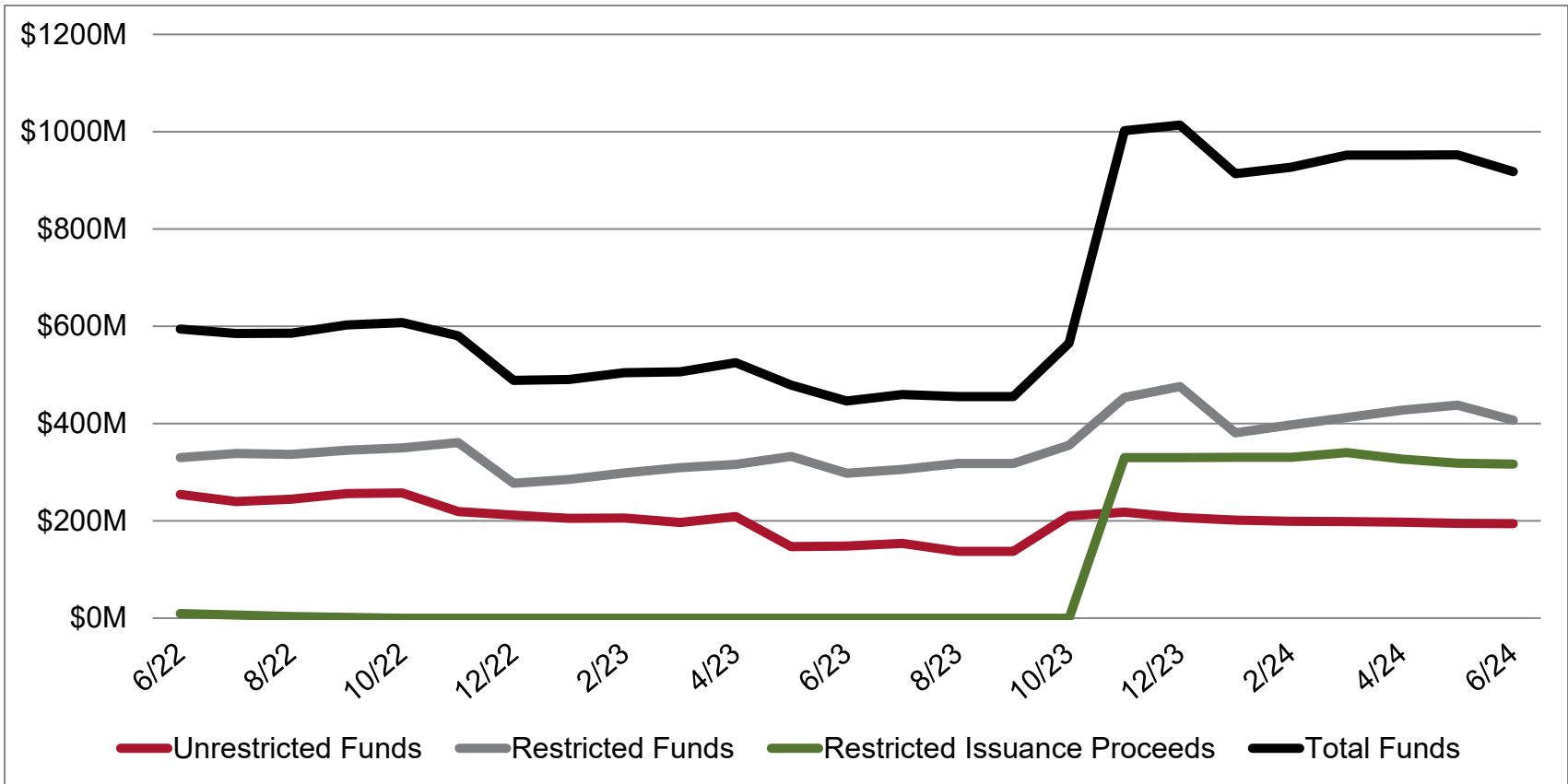

## Market Value (\$ in Thousands)

	8/31/23	9/30/23	10/31/23	11/30/23	12/31/23	1/31/24	2/29/24	3/31/24	4/30/24	5/31/24	6/30/24	7/31/24
<b>UNRESTRICTED FUNDS</b>												
REVENUE FUND	33,063	26,264	37,289	29,187	27,175	33,063	29,147	32,514	34,396	38,292	21,695	34,910
GENERAL FUND	120,900	111,065	172,622	188,871	179,896	168,702	169,80	166,109	162,709	156,982	172,844	153,710
<b>SUB TOTAL UNRESTRICTED FUNDS</b>	<b>153,963</b>	<b>137,329</b>	<b>209,911</b>	<b>218,058</b>	<b>207,071</b>	<b>201,765</b>	<b>198,927</b>	<b>198,623</b>	<b>197,106</b>	<b>195,274</b>	<b>194,539</b>	<b>188,619</b>
<b>RESTRICTED FUNDS</b>												
RESERVE MAINTENANCE FUND	8,540	11,014	15,370	18,431	21,894	21,975	25,856	28,859	32,054	32,003	34,632	31,274
TURNPIKE TRUST FUND	47,381	47,400	47,555	47,983	48,422	48,655	48,601	48,780	48,716	49,005	49,244	44,520
2023 CONSTRUCTION FUNDS	0	0	0	330,111	330,104	330,768	330,840	331,566	326,941	318,837	316,487	309,119
<b>DEBT SERVICE FUNDS</b>												
SERIES 2017 DEBT SERVICE	34,627	41,512	48,513	55,514	62,515	6,967	13,935	20,902	27,869	34,837	21,335	28,302
SERIES 2018 DEBT SERVICE	2,518	3,767	5,023	6,279	7,535	1,256	2,512	3,767	5,023	6,279	0	1,255
SERIES 2020AB DEBT SERVICE	20,595	23,714	26,906	30,097	33,289	3,211	6,422	9,633	12,845	16,056	14,605	17,816
SERIES 2023 DEBT SERVICE				80,574	80,917	75,683	75,683	75,683	75,683	75,683	62,327	62,645
TOTAL DEBT SERVICE ACCTS	57,740	68,994	80,442	172,143.16	184,255	87,117	99,855	109,986	121,420	132,855	98,267	110,019
SECOND SENIOR RESERVE FUND	139,163	137,847	161,606	164,300	167,161	167,506	165,956	166,426	165,925	167,555	168,606	170,995
<b>PIKEPASS FUNDS:</b>												
PIKEPASS DISBURSEMENT DDA	100	95	93	73	83	94	44	82	113	110	120	117
PIKEPASS PREPAYMENT DDA	8,239	9,409	7,551	5,437	7,700	8,578	9,195	5,598	8,199	3,697	2,751	1,305
PIKEPASS PREPAYMENT TRUST	44,575	44,441	42,879	45,090	46,606	46,798	47,682	52,456	51,387	52,635	53,300	54,232
TOTAL PIKEPASS FUNDS	52,914	52,995	50,523	50,600	54,389	55,470	56,921	58,136	59,699	56,442	56,172	55,654
<b>SUB TOTAL RESTRICTED FUNDS</b>	<b>305,737</b>	<b>318,200</b>	<b>355,496</b>	<b>783,899</b>	<b>806,225</b>	<b>711,491</b>	<b>728,029</b>	<b>743,752</b>	<b>754,757</b>	<b>756,696</b>	<b>723,408</b>	<b>412,462</b>
<b>TOTAL FUNDS</b>	<b>459,700</b>	<b>455,530</b>	<b>565,407</b>	<b>1,001,947</b>	<b>1,013,295</b>	<b>913,256</b>	<b>926,956</b>	<b>942,375</b>	<b>951,863</b>	<b>951,970</b>	<b>951,970</b>	<b>910,200</b>



**As of July 31, 2024**

	1 Mo	3 Mo	YTD	1 YR	ITD	Begin Mkt Value	Ending Mkt Value	Accrued Income	Cash Flows
OTA REVENUE FUND	0.4300	0.9300	2.0500	3.4700	1.6900	\$21,793,025.07	\$36,820,505.72	\$107,375.56	\$14,920,105.09
OTA RESERVE MAINTENANCE FUND	0.4100	1.2100	2.8000	4.7000	2.8100	\$31,243,748.87	\$27,867,280.66	\$123,809.71	<b>-\$3,500,277.92</b>
OTA GENERAL FUND	0.4100	1.2100	2.8600	4.9600	3.3600	\$151,050,510.28	\$133,835,669.50	\$593,179.72	<b>-\$17,808,020.50</b>
OTA PIKEPASS PRE-PAYMENT AGENCY ACC	1.6500	5.5100	7.5100	11.2500	5.2700	\$53,429,663.46	\$54,310,831.46	\$79,144.71	\$0.00
OTA TURNPIKE TRUST FUND	0.4300	1.3100	3.0700	5.3600	3.0400	\$9,811,209.12	\$4,534,419.26	\$25,960.78	<b>-\$5,302,750.64</b>
OTA 2ND SR. RESERVE	0.4100	1.2600	2.9600	5.1700	4.5700	\$11,725,364.74	\$11,773,868.31	\$48,503.57	\$0.00
ZOTA GENERAL FUND MANAGED	1.4200	3.3500	2.0400	5.5800	0.8300	\$12,622,710.65	\$12,801,573.84	\$82,507.06	\$0.00
OTA RESERVE MAINTENANCE MANAGED	0.5300	1.4200	2.7900	5.4700	1.3500	\$3,529,959.61	\$3,548,624.23	\$20,642.84	\$0.00
OTA TURNPIKE TRUST MANAGED	1.1000	2.3600	2.6200	5.6200	1.2600	\$39,694,706.99	\$40,129,783.69	\$192,491.02	\$0.00
OTA 2ND SR. RESERVE MANAGED	1.4000	3.4400	2.1200	5.1000	1.8200	\$158,102,291.07	\$160,313,555.85	\$1,376,034.52	\$0.00
OTA SERIES 2017A INTEREST	1.0800	1.8700	3.1300	5.2500	1.7500	\$36,081.05	\$1,655,323.87	\$5,218.14	\$1,614,024.68
OTA SERIES 2017C INTEREST FUND	1.0800	1.8700	3.1300	5.2500	1.9400	\$17,316.56	\$794,447.91	\$2,504.37	\$774,626.98
OTA SERIES 2017C CONSTRUCTION FUND	0.0000	0.0000	0.0000	0.0000	0.6500	<b>-\$0.02</b>	<b>-\$0.02</b>	\$0.00	\$0.00
OTA SERIES 2017D INTEREST FUND	1.0800	1.8700	3.1200	5.2400	1.9300	\$14,248.37	\$653,685.64	\$2,060.64	\$637,376.63
OTA SERIES 2017D PRINCIPAL FUND	0.4400	1.2700	2.5000	4.7200	1.9800	\$18,281,637.04	\$21,332,133.61	\$90,050.30	\$2,960,446.27
OTA SERIES 2017E INTEREST FUND	1.0800	1.8700	3.1300	5.2400	1.9300	\$6,949.71	\$318,837.79	\$1,005.08	\$310,883.00
OTA SERIES 2017E PRINCIPAL FUND	0.4400	1.2700	2.5000	4.7100	3.3800	\$3,140,234.51	\$3,664,217.93	\$15,467.93	\$508,515.49
OTA SERIES 2018A INTEREST FUND	5399.120	5422.090	5604.830	5604.830	106.0800	\$0.00	\$1,232,325.31	\$3,971.26	\$1,228,354.05
	0	0	5490.3300	0					
OTA SERIES 2020A INTEREST	0.0000	0.0000	0.0000	0.0000	0.0000	\$0.02	\$626,203.12	0.0000	\$626,203.10
OTA SERIES 2020A PRINCIPAL	0.0000	0.0000	0.0000	0.0000	0.0000	\$5,725,000.02	\$6,707,467.30	0.0000	\$982,467.28

As of July 31, 2024

	1 Mo	3 Mo	YTD	1 YR	ITD	Begin Mkt Value	Ending Mkt Value	Accrued Income	Cash Flows
OTA SERIES 2020B INTEREST	0.0000	0.0000	0.0000	0.0000	0.0000	\$0.00	\$153,325.76	0.0000	\$153,325.76
OTA SERIES 2020B PRINCIPAL	0.0000	0.0000	0.0000	0.0000	0.0000	\$8,880,000.00	\$10,403,896.79	0.0000	\$1,523,896.79
OTA SERIES 2023 INTEREST FUND	0.4400	1.3000	3.0200	0.0000	3.9200	\$62,644,722.50	\$62,920,755.39	\$276,032.89	\$0.00
OTA SERIES 2023 CONSTRUCTION	0.0000	0.0000	0.0000	0.0000	0.0000	\$0.00	\$318,836,663.72	\$0.00	(\$8,105,278.26)
<b>OTA CONSOLIDATED</b>	<b>0.7900</b>	<b>1.0700</b>	<b>1.5300</b>	<b>4.3700</b>	<b>2.2700</b>	<b>\$604,679,208.50</b>	<b>\$934,713,645.19</b>	<b>\$1,112,996.70</b>	<b>(\$1,605,436.26)</b>

Allocation Summary

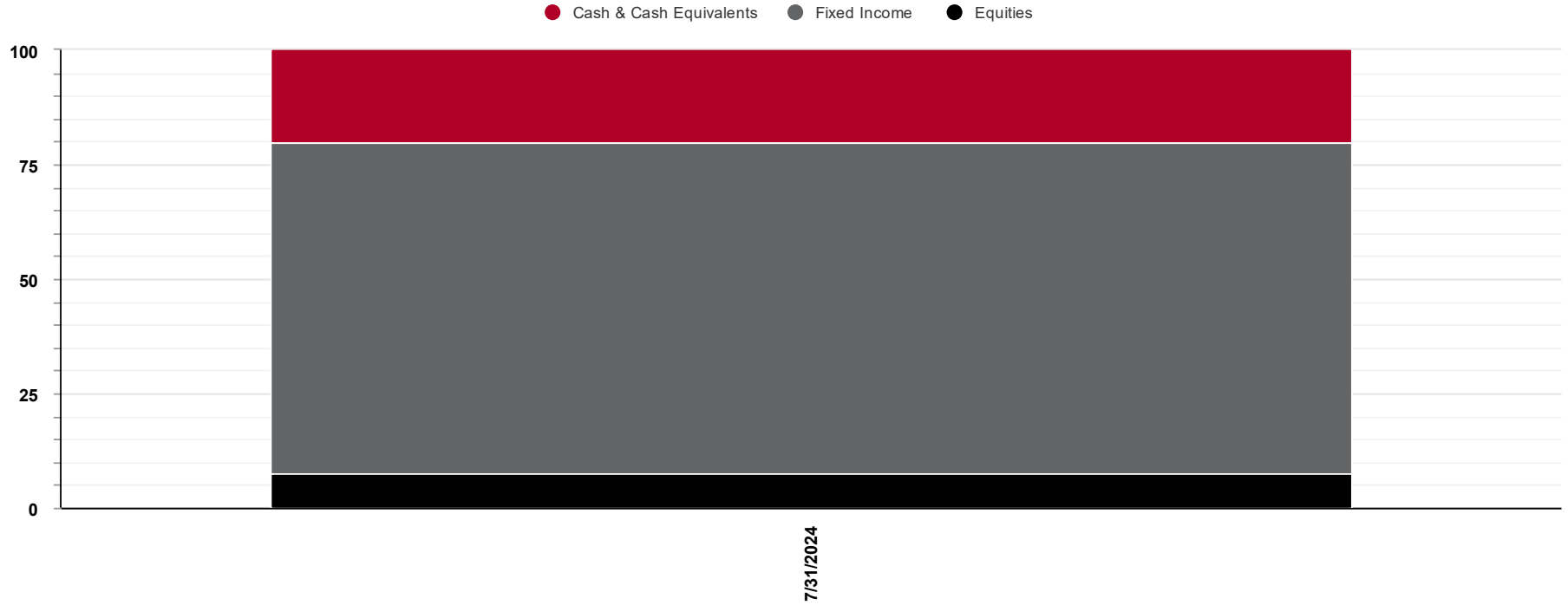

Class	Ending Market Value	Current Portfolio Allocation	Target Allocation	Difference (%)	Difference (\$)
Cash & Cash Equivalents	63,247,301	20.2%	-	20.2%	63,247,301
Fixed Income	225,676,911	72.2%	-	72.2%	225,676,911
Equities	23,604,998	7.6%	-	7.6%	23,604,998
<b>TOTAL PORTFOLIO</b>	<b>312,529,210</b>	<b>100%</b>	<b>0%</b>	<b>-</b>	<b>-</b>

Allocation Summary

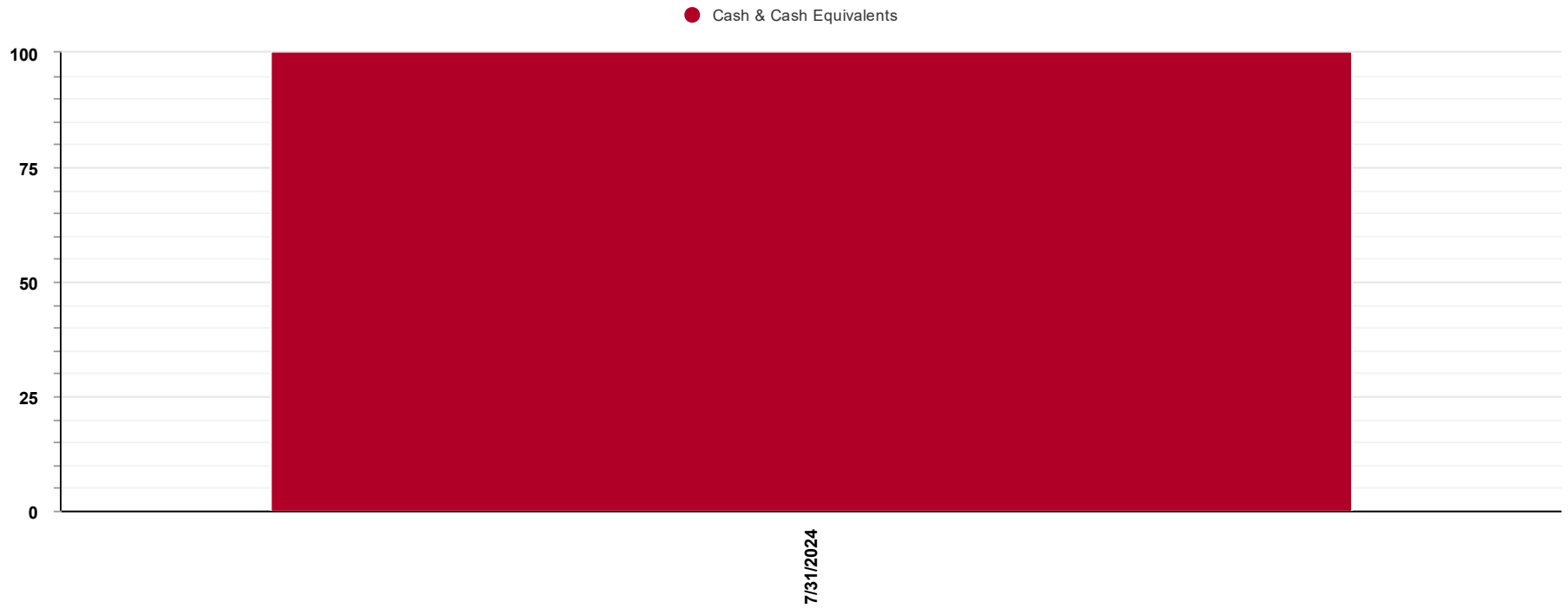

Class	Ending Market Value	Current Portfolio Allocation	Target Allocation	Difference (%)	Difference (\$)
Cash & Cash Equivalents	203,057,875	100.0%	-	100.0%	203,057,875
<b>TOTAL PORTFOLIO</b>	<b>203,057,875</b>	<b>100%</b>	<b>0%</b>	<b>-</b>	<b>-</b>